

Volume I

# CNMI and Guam Stormwater Management Manual

Final – October 2006



Prepared by:  
**Horsley Witten Group, Inc.**



Prepared for:  
**Commonwealth of the Northern Mariana Islands  
and the Territory of Guam**



**<This page left blank intentionally>**



## *Table of Contents*

<b>1.0</b>	<b>Introduction to the Manual</b>	
1.1	Purpose and Scope of the Manual .....	1-1
1.2	Organization of the Manual .....	1-3
	1.2.1 Chapter Descriptions.....	1-3
	1.2.2 General Information.....	1-5
1.3	Regulatory Authority, Applicability, and Review .....	1-6
1.4	Symbols and Acronyms .....	1-7
1.5	Stormwater Management Background .....	1-9
	1.5.1 Why Stormwater Matters: the Impact of Stormwater Runoff on the Waters of CNMI and Guam.....	1-9
	1.5.2 The Concept of Integrated Stormwater Management.....	1-26
<b>2.0</b>	<b>Stormwater Treatment Practice Standards and Criteria</b>	
2.1	Construction Stormwater Treatment Criteria and Standards.....	2-1
	2.1.1 General Performance Standards.....	2-1
	2.1.1.1 Designation of Stormwater “Hotspot” Land Uses .....	2-3
	2.1.2 Treatment Criteria.....	2-4
2.2	Post-construction Unified Stormwater Sizing Criteria .....	2-5
	2.2.1 General Performance Standards.....	2-5
	2.2.2 Treatment Criteria.....	2-6
	2.2.2.1 Recharge Criteria ( $Re_v$ ).....	2-9
	2.2.2.2 Water Quality Criteria ( $WQ_v$ ).....	2-15
	2.2.2.3 Overland Erosion and Channel Protection Criteria ( $Cp_v$ ) .....	2-16
	2.2.2.4 Overbank Flood Control Criteria ( $Q_{p-25}$ ).....	2-19
	2.2.3 Downstream Analysis for $Q_{p-25}$ .....	2-19
	2.2.4 Sample Calculations.....	2-21
<b>3.0</b>	<b>Acceptable Best Management Practices (BMPs)</b>	
3.1	Erosion and Sediment Control for Construction Sites.....	3-1
3.2	Acceptable Post-construction BMPs.....	3-6
	3.2.1 Acceptable Water Practice List.....	3-7
	3.2.2 Structural Practices that Meet Groundwater Recharge ( $Re_v$ ) Requirements .....	3-9
	3.2.3 Structural BMPs that Meet Water Quantity Requirements ( $Cp_v/Q_{p-25}$ ) and Pretreatment Functions .....	3-10

3.2.4 Minimum Design Criteria for BMPs .....	3-10
3.2.4.1 Stormwater Ponds .....	3-11
3.2.4.2 Stormwater Wetlands.....	3-25
3.2.4.3 Stormwater Infiltration Practices .....	3-33
3.2.4.4 Stormwater Filtering Systems.....	3-43
3.2.4.5 Open Channel Systems .....	3-55
3.2.4.6 Limited Applicability Stormwater BMPs .....	3-63

## Glossary

## References

### Appendix A - Most Common Best Management Practices for Construction Sites

- A1: Check Dam
- A2: Diversion Dike/Swale
- A3: Level Spreader
- A4: Perimeter Dike/Swale
- A5: Sediment Basin
- A6: Sediment Trap
- A7: Silt Fence
- A8: Stabilized Construction Entrance
- A9: Storm Drainage Inlet Protection
- A10: Turbidity Curtain
- A11: Vegetated and Lined Waterways
- A12: Rock Outlet Protection
- A13: Erosion Control Blankets
- A14: Stabilization with Vegetation, Mulch, or Topsoil

**LIST OF FIGURES**

Figure 1.1 - Water Balance at Developed and Undeveloped Sites .....	1-10
Figure 1.2 - Relationship Between Impervious Cover and Runoff Coefficient (Schueler, 1987).....	1-10
Figure 1.3 - Sediment-laden runoff covers a road in CNMI after a rain storm (CNMI DEQ) .	1-11
Figure 1.4 - Monthly mean rainfall at Saipan International Airport and Guam’s Andersen Air Force Base (Lander, 2004).....	1-11
Figure 1.5 - Annual precipitation values in Saipan (CNMI) and Guam .....	1-12
Figure 1.6 - The Ugum River flows through southern Guam (Pacific Worlds, 2003) .....	1-13
Figure 1.7 - Hydrographs Before and After Development .....	1-14
Figure 1.8 - Sediment washed into a catch basin during a storm event.....	1-14
Figure 1.9 - Chickens are a familiar site on the islands and contribute to the bacteria and nutrient loading of waterbodies .....	1-15
Figure 1.10 - Geologic and groundwater resource characteristics of Saipan (CNMI) .....	1-17
Figure 1.11 - Effects of groundwater withdrawal on the potable part of the freshwater lens in a high permeability island aquifer .....	1-18
Figure 1.12 - Saipan Groundwater Management Zones (CNMI, 2004).....	1-20
Figure 1.13 - Different soil horizons are clearly visible at a site in CNMI .....	1-21
Figure 1.14 - Water tumbles over volcanic formations in this stream in CNMI .....	1-22
Figure 1.15 - Stream Location and Surface Water Use Classification for Saipan (CNMI).....	1-23
Figure 1.16 - Surface Water Streams of Guam.....	1-24
Figure 1.17 - Agana Bay in Guam.....	1-26
Figure 1.18 - The Integrated Stormwater Management Site Design Process .....	1-27
Figure 2.1 - Recharge Augmentation Zones and Water Quality Criteria Designations for Guam .....	2-10
Figure 2.2 - Recharge Augmentation Zones and Water Quality Criteria Designations for Saipan (CNMI).....	2-11
Figure 2.3 -Recharge Augmentation Zones and Water Quality Criteria Designations for Tinian (CNMI) and Rota (CNMI).....	2-12
Figure 2.4 -Relationship Between Recharge Requirement and Site Impervious Cover.....	2-14
Figure 2.5 -Water Quality Volume Requirements as a Function of Site Imperviousness.....	2-16
Figure 2.6 - Criteria adjustment factors based on annual precipitation values (baseline precipitation 100 inches).....	2-18
Figure 2.7 - Graphical Depictions of Coincident Peak Phenomena (Ogden, 2000).....	2-20
Figure 2.8 - Medium Density Residential Site Plan in Guam.....	2-22
Figure 2.9 - Detention Time vs. Discharge Ratios.....	2-24
Figure 2.10 - Approximate detention basin routing for rainfall types I, IA, II, III.....	2-27
Figure 3.1 - Micropool Extended Detention Pond (P-1).....	3-12
Figure 3.2 - Wet Pond (P-2).....	3-13
Figure 3.3 - Wet Extended Detention Pond (P-3).....	3-14
Figure 3.4 - Typical Stormwater Pond Geometry Criteria .....	3-18
Figure 3.5 - Shallow Marsh (W-1).....	3-26
Figure 3.6 - Extended Detention Wetland (W-2).....	3-27
Figure 3.7 - “Pocket” Pond (W-3) .....	3-28
Figure 3.8 - Infiltration Trench (I-1).....	3-34
Figure 3.9 - Infiltration Basin (I-2).....	3-35

Figure 3.10 - Sand Filter (F-1).....	3-44
Figure 3.11 - Organic Filter (F-2).....	3-45
Figure 3.12 – Bioretention (F-3).....	3-46
Figure 3.13 - Dry Swale (O-1).....	3-56
Figure 3.14 - Wet Swale (O-2) .....	3-57
Figure 3.15 - Dry Detention Pond (LA-1) .....	3-64
Figure 3.16 - Underground Storage Vault (LA-2).....	3-65
Figure 3.17 - Filter Strips (LA-3) .....	3-66
Figure 3.18 - Grass Channel (LA-4).....	3-67
Figure 3.19 - Hydrodynamic Device (LA-5) .....	3-68
Figure 3.20 - Oil and Grit Separator (LA-6).....	3-68

## LIST OF TABLES

Table 1.1 - Key Symbols and Acronyms Cited in Manual.....	1-7
Table 1.2 - Average Annual Rainfall by Location for Guam and CNMI.....	1-13
Table 2.1 - Classification of Stormwater Hotspot Land Uses .....	2-4
Table 2.2 – CNMI and Guam Required Unified Sizing Criteria for Stormwater Management Practices .....	2-8
Table 2.3 - Summary of Recharge Criteria for CNMI and Guam based on Surficial Geology.....	2-13
Table 2.4 - Water Quality Volume (WQ <sub>v</sub> ) Requirement as a Function of Land Use and Resource Quality.....	2-15
Table 2.5 - 24-hour Rainfall Events for Northern Guam.....	2-17
Table 2.6 - Mountain View Estates “B” Pre-Developed – TR-55 Output.....	2-25
Table 2.7 - Mountain View Estates “B” Post-Developed – TR-55 Output .....	2-26
Table 2.8 - Summary of Required Volumes for Shopping Center Example .....	2-27
Table 3.1 - Most Common Best Management Practices for Construction Sites, Detailed in Appendix A.....	3-2
Table 3.2 - Full Suite of Best Management Practices for Construction Sites.....	3-3
Table 3.3 - List of BMPs Acceptable for Water Quality .....	3-8
Table 3.4 - Water Quality Volume Distribution in Pond Designs.....	3-17
Table 3.5 - Design Infiltration Rates for Different Soil Texture Classes .....	3-38
Table 3.6 - Guidelines for Filter Strip Pretreatment Sizing.....	3-48



## *1.0 Introduction to the Manual*

### **1.1 Purpose and Scope of the Manual**

Stormwater management has evolved dramatically throughout the United States and its territories and commonwealths since it was first adopted and applied in several regions of the country as early as the late 1970's. Much has been learned about what works in the field and what doesn't. The ultimate goal of the Commonwealth of the Northern Mariana Islands (CNMI) and Guam Stormwater Management Manual is to compile this hard-won knowledge and experience into a single comprehensive design handbook that is useful to engineers, plan reviewers and the regulated community. Most importantly, the Manual provides a framework to ensure the effective implementation of stormwater management practices to protect the vital water resources of the Northern Mariana Islands and Guam.

The CNMI Division of Environmental Quality (DEQ) and the Guam Environmental Protection Agency (GEPA) have identified a need for a new guidance manual to assist the local engineering and development communities and local government agencies in developing and implementing stormwater and erosion control plans that adequately address nonpoint source pollution through the use of currently accepted best management practices (BMPs). As part of the development of the manual, the CNMI DEQ and the GEPA commissioned Horsley Witten Group (formerly Horsley & Witten, Inc.) to develop comprehensive stormwater criteria for review and comment by the public prior to developing this Final Manual.

This manual is also generally intended to update and replace previous reference manuals in CNMI and Guam, most notably the *Guam Storm Drainage Manual* (U.S. Army Corps, 1980), *Stormwater Control Handbook* (Soil and Water Conservation Districts of CNMI, 1989), and the *Erosion and Sediment Control Manual* (GEPA, 2000). Unfortunately, the sheer volume of material and diversity of topics of the prior materials make it impossible to completely replace these reference materials. Designers, regulators and the regulated community will still need to rely on prior publications for reference to the following topics:

- ▶ General Hydrology
- ▶ Drainage Design/Pipe Sizing
- ▶ Floodplain Management
- ▶ Design Specifications for Erosion and Sediment Control Practices<sup>1</sup>

---

<sup>1</sup> Erosion and Sediment Control Practices are discussed in **Chapter 3**, and the fourteen most commonly used practices are included in **Appendices A1-A14**.

The purpose of this manual is threefold:

1. to protect the waters of the CNMI and Guam from the adverse impacts of urban stormwater runoff,
2. to provide design guidance on the most effective best management practices (BMPs) for new development sites and redevelopment sites both during and post construction, and
3. to improve the quality of BMPs that are constructed in CNMI and Guam, specifically in regard to their performance, longevity, safety, ease of maintenance, community acceptance and environmental benefit.



## 1.2 Organization of the Manual

Volume I of the CNMI/Guam Stormwater Management Manual provides designers a general overview on local stormwater issues and how to size and design BMPs to comply with stormwater performance standards. Volume II of this manual contains more detailed information on how to select and locate BMPs at a development site, landscaping guidelines, BMP construction specifications, step-by-step BMP design examples and other assorted design tools.

### 1.2.1 Chapter Descriptions

The manual is organized as follows:

#### ***VOLUME I***

Volume I contains a total of three chapters, including:

Chapter 1. Introduction. This chapter contains contact information and explains the background of stormwater management and the current stormwater issues facing CNMI and Guam.

Chapter 2. Stormwater Treatment Practice Criteria and Standards. This chapter describes the criteria for stormwater treatment during construction. Chapter 2 also explains the post-construction unified sizing criteria for recharge, water quality, channel protection, and overbank flood control in the CNMI and Guam.

Chapter 3. Acceptable Best Management Practices. This chapter lists the BMPs that are generally applicable for use during construction activities. In addition, the chapter outlines the five groups of acceptable post-construction structural BMPs that can be used to meet the specific criteria outlined in Chapter 2 and presents specific performance criteria and guidelines for the design of the five groups of structural BMPs—Stormwater Ponds, Stormwater Wetlands, Infiltration Practices, Filtering Systems, and Open Channel Practices.

#### ***VOLUME II***

Volume II contains the technical information needed to actually design, landscape, and construct a BMP. There are a total of nine chapters, including:

Chapter 1. Introduction to Volume II.

Chapter 2. Selecting and Locating the Most Effective BMP System. This chapter presents guidance on how to select the best BMP or group of practices at a development site, as well as environmental and other factors to consider when actually locating each BMP. The chapter contains six comparative matrices that evaluate BMPs from the standpoint of the following factors:

- ▶ Land Use
- ▶ Physical Feasibility
- ▶ Watershed Factors
- ▶ Stormwater Management Capability
- ▶ Pollutant Removal
- ▶ Community and Environmental Factors

Chapter 2 is designed so that the reader can use the matrices in a step-wise fashion to identify the most appropriate BMP or group of practices to use at a site.

Chapter 3. Better Site Design and Non-structural BMPs. This chapter presents a suite of methods that designers and developers can take advantage of to reduce the stormwater runoff at a site. These methods are grouped into the following three categories: Preservation of Natural Features and Conservation Design, Reduction of Impervious Cover, and Utilization of Natural Features and Source Control for Stormwater Management.

Chapter 4. Step-by-Step Design Examples. Four design examples are provided to help designers and plan reviewers better understand the new criteria in this Manual. The examples demonstrate how the new stormwater sizing criteria are applied, as well as some of the design procedures and performance criteria that should be considered when siting and designing a stormwater best management practice. A stormwater design for a typical single-lot/small-scale house is also included.

Chapter 5. Landscaping Guidance. Good landscaping can often be an important factor in the performance and community acceptance of many stormwater BMPs. The Landscaping Guide provides general background on how to determine the appropriate landscaping region and hydrologic zone in CMNI and Guam. Chapter 5 also includes tips on how to establish more functional landscapes within stormwater BMPs.

Chapter 6. BMP Design and Construction Specifications. Good designs only work if careful attention is paid to proper construction techniques and materials. Chapter 6 contains detailed specifications for constructing infiltration practices, filters, bioretention areas and open channels.

Chapter 7. Maintenance Plans. On-going maintenance is vital to ensure that BMPs continue to function as designed. Chapter 7 includes guidance on creating an appropriate maintenance plan and example checklists that can be incorporated in the plan.

Chapter 8. Soils Information. One of the most important site characteristics to consider when choosing stormwater BMPs is the type of soil at that location. Chapter 8 provides a brief introduction to soils, as well as a description of field procedures needed when evaluating a test pit.

Chapter 9. Assorted Design Tools. Chapter 9 provides additional information to help designers with the incorporation of stormwater BMPs at their site. This chapter includes sections on infiltration and bioretention testing requirements, miscellaneous BMP details, hydrologic analysis tools, and critical erosive velocities for grass and soil.

## **1.2.2 General Information**

### **How to Order Printed Copies of the Manual**

Printed copies of the Manual or the Manual on CD can be ordered by calling the CNMI DEQ at 670-664-8500 or the Guam EPA at 671-475-1635.

### **How to Find the Manual on the Internet**

Both volumes of the CNMI/Guam Stormwater Management Manual are also available in Adobe Acrobat PDF document format for download at the following Internet addresses:

CNMI Division of Environmental Quality: <http://www.deq.gov.mp/>

Guam Environmental Protection Agency: <http://www.guamepa.govguam.net/>

### **Key Contact Information for Permitting in CNMI and Guam**

If you have any technical questions or comments on the Manual, please send an email to:

Brian Bearden (CNMI DEQ) [brian.bearden@deq.gov.mp](mailto:brian.bearden@deq.gov.mp) or Domingo Cabusao (GEPA) [dcabusao@guamepa.govguam.net](mailto:dcabusao@guamepa.govguam.net).

### 1.3 Regulatory Authority, Applicability, and Review

Since 1980, Guam has used the *Guam Storm Drainage Manual* developed by the U.S. Army Corps of Engineers to provide technical guidance for stormwater planning and design (U.S. Army Corps, 1980), as well as the more recently updated *Erosion and Sediment Control Manual* (GEPA, 2000). Since 1989, the Commonwealth of the Northern Mariana Islands (CNMI) has used the *Stormwater Control Handbook* developed by the Soil and Water Conservation Districts of Saipan and Northern Islands, Tinian and Aguiguan, and Rota to guide stormwater planning and design. This manual is generally intended to update and replace the documents listed above. Unfortunately, the sheer volume of material and diversity of topics of the prior materials make it impossible to completely replace these reference materials. Designers, regulators and the regulated community will still need to rely on prior publications for reference to the following topics:

- ▶ General Hydrology
- ▶ Drainage Design/Pipe Sizing
- ▶ Floodplain Management
- ▶ Design Specifications for Erosion and Sediment Control Practices<sup>1</sup>

Permit applications on the internet: CNMI <http://www.deq.gov.mp/permits/permitpage2.htm>  
Guam <http://www.guamepa.govguam.net/permits/index.html>

---

<sup>1</sup> Erosion and Sediment Control Practices are discussed in **Chapter 3**, and the fourteen most commonly used practices are included in **Appendices A1-A14**.

## 1.4 Symbols and Acronyms

As an aid to the reader, the following table outlines the symbols and acronyms that are used throughout the text. In addition, a glossary is provided at the end of this volume that defines the terminology used in the text.

<b>Table 1.1 Key Symbols and Acronyms Cited in Manual</b>			
A	drainage area	NPDES	National Pollutant Discharge Elimination System
$A_f$	filter bed area	NRCS	Natural Resources Conservation Service
$A_s$	surface area, sedimentation basin	P	precipitation depth
BMP	best management practice	$Q_0$	peak outflow discharge
$C_{p_v}$	channel protection storage volume	$Q_{p-25}$	overbank flood control storage volume
CN	curve number	$Re_v$	recharge volume
CNMI	Commonwealth of Northern Mariana Islands	$R_v$	volumetric runoff coefficient
$d_f$	depth of filter bed	SD	separation distance
DEQ	Division of Environmental Quality	SWPPP	stormwater pollution prevention plan
ED	extended detention	SD	separation distance
EPA	Environmental Protection Agency	$t_c$	time of concentration
$f_c$	soil infiltration rate	$t_f$	time to drain filter bed
FEMA	Federal Emergency Management Agency	TR-20	Technical Release No. 20 Project Formulation-Hydrology, computer program
fps	feet per second	TR-55	Technical Release No. 55 Urban Unit Hydrology for Small Watersheds
$h_f$	head above filter bed	TSS	total suspended solids
HEC-RAS	Hydrologic Engineering Center - River Analysis System (US Army Corps of Engineers)	USEPA	United States Environmental Protection Agency
HSG	hydrologic soil group	$V_t$	total volume
I	percent impervious cover	$V_v$	volume of voids
Ia	initial abstraction	$WQ_v$	water quality storage volume
K	coefficient of permeability		

**<This page intentionally left blank>**

## 1.5 Stormwater Management Background

The Commonwealth of the Northern Mariana Islands (CNMI) and Guam receive a lot of rain! The average annual rainfall exceeds 100 inches per year in many locations. During the rainy season, typhoons can drop 10-15 inches of precipitation in one storm event.

These climatic conditions combined with the region's unique limestone, volcanic geologic formations, sensitive water resources and significant land development forces make stormwater a very significant environmental and economic issue.

Historically, stormwater has been viewed as strictly a drainage issue and has been routed to the nearest discharge location, has been infiltrated into the highly-permeable limestone with little or no pre-treatment, or has been conveyed directly to receiving waters.

Along with development comes an increased amount of impervious surfaces, precluding the natural infiltration of rainwater into the underlying groundwater system. As a result, the groundwater "lens" (which serves as the principle drinking water source) is depleted. Or, in the instances where stormwater is infiltrated without adequate pre-treatment, groundwater quality is degraded.

In this section, water quality and quantity issues related to stormwater are discussed. This section also describes sensitive environmental resources areas, such as drinking water supplies and wetlands.

### 1.5.1 Why Stormwater Matters: Impact of Stormwater Runoff on CNMI and Guam Watersheds

Urban development has a profound influence on the quality of the waters of CNMI and Guam. To start, development dramatically alters the local hydrologic cycle (see **Figure 1.1**). The hydrology of a site changes during the initial clearing and grading that occur during construction. Trees that had intercepted rainfall are removed, and natural depressions that had temporarily ponded water are graded to a uniform slope. The spongy humus layer of the native vegetation that had absorbed rainfall is scraped off, eroded or severely compacted. Having lost its natural storage capacity, a cleared and graded site can no longer prevent rainfall from being rapidly converted into stormwater runoff.

The situation worsens after construction. Rooftops, roads, parking lots, driveways and other impervious surfaces no longer allow rainfall to soak into the ground. Consequently, most rainfall is directly converted into stormwater runoff. This phenomenon is illustrated in **Figure 1.2**, which shows the increase in the volumetric runoff coefficient ( $R_v$ ) as a function of site imperviousness. The runoff coefficient expresses the fraction of rainfall volume that is converted into stormwater runoff. As can be seen, the volume of stormwater runoff increases sharply with impervious cover. For example, a one-acre parking lot can produce 16 times more stormwater runoff than a one-acre meadow each year (Schueler, 1994).

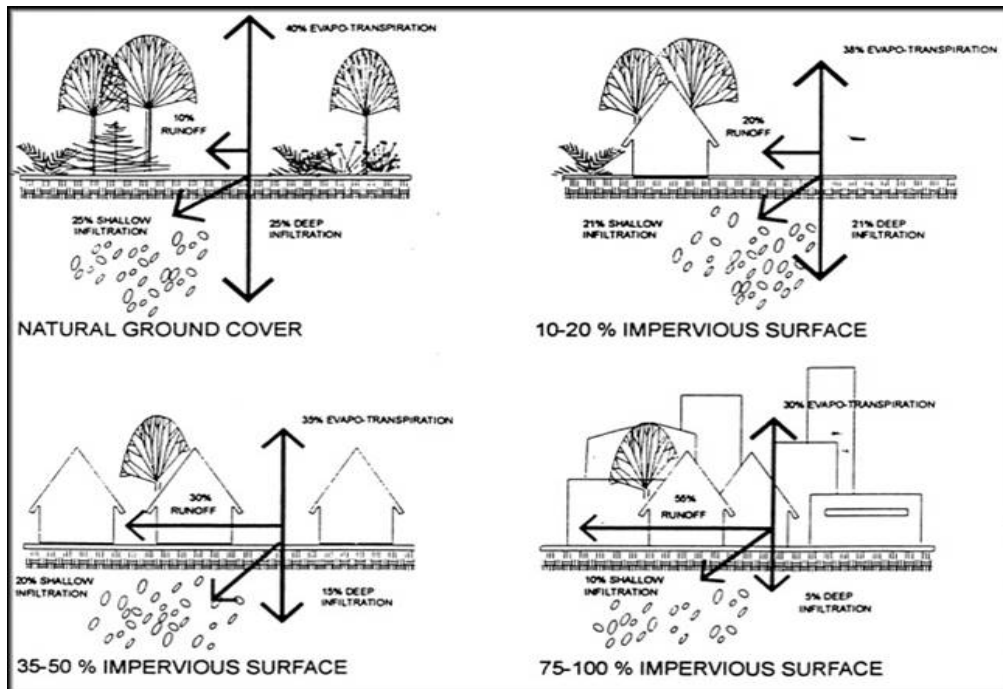

**Figure 1.1 Water Balance at Developed and Undeveloped Sites (adapted from Prince George’s County, 1999)**

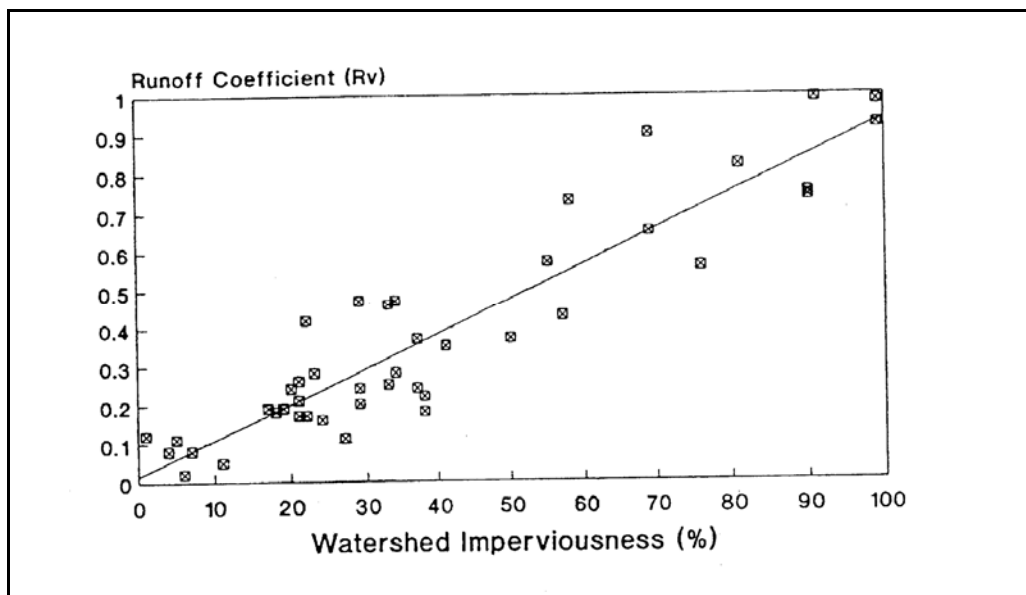

**Figure 1.2 Relationship Between Impervious Cover and Runoff Coefficient (Schueler, 1987)**

The increase in stormwater runoff can be too much for the natural drainage system to handle. As a result, the drainage system is often “improved” to rapidly collect runoff and quickly convey it away (using curb/gutters, enclosed storm sewers, and lined channels). The stormwater runoff is subsequently discharged to downstream waters, such as streams, wetlands, lagoons, or near-shore bays.



**Precipitation Characteristics**

To really understand the stormwater issues in an area, one must first be familiar with the local precipitation characteristics. Two distinct climatic seasons occur on the CNMI and Guam: wet and dry (Duenas & Associates, 1996). The wet season on Guam, also known as the typhoon season, typically occurs from August to October, and the dry season usually occurs from December to June. November and July are considered to be the transitional months, with November marking the transition from wet to dry, and July marking the transition from dry to wet.



**Figure 1.3 Sediment-laden runoff covers a road in CNMI after a rain storm (CNMI DEQ)**

In northern Guam, the seasonal average rainfall during the wet season is about 12 inches per month (Camp, Dresser & McKee, Inc., 1982). During the dry season, the seasonal average rainfall is about 5 inches per month on the northern portion of the island. Distinct wet and dry seasons occur in the CNMI as well. The months of July through November are considered to be the wet season and the months of January through May are considered to be the dry season (Carruth, 2003). December and June are considered to be the transitional months. On Saipan, 67% (about 53 inches) of the rain falls during the wet season, and 21% (about 17 inches) of the rain falls during the dry season. The transitional months receive the remaining 12% (about 10 inches) of the annual rainfall. **Figure 1.4** shows a comparison of seasonal precipitation, and **Figure 1.5** shows the annual precipitation values based on location for Saipan (CNMI) and Guam.

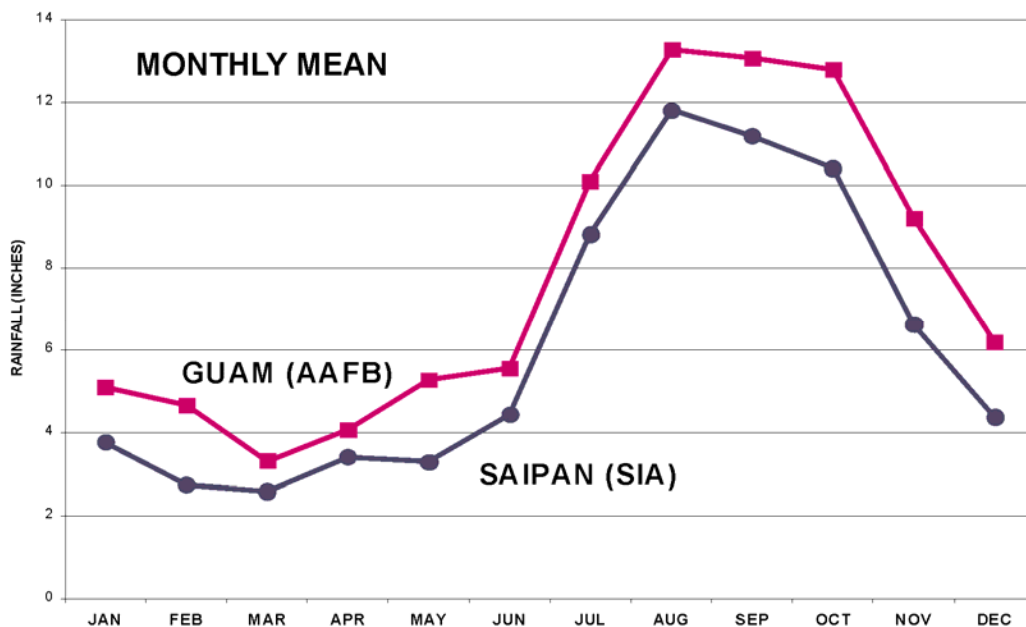

**Figure 1.4 Monthly mean rainfall at Saipan International Airport and Guam’s Andersen Air Force Base (Lander, 2004)**

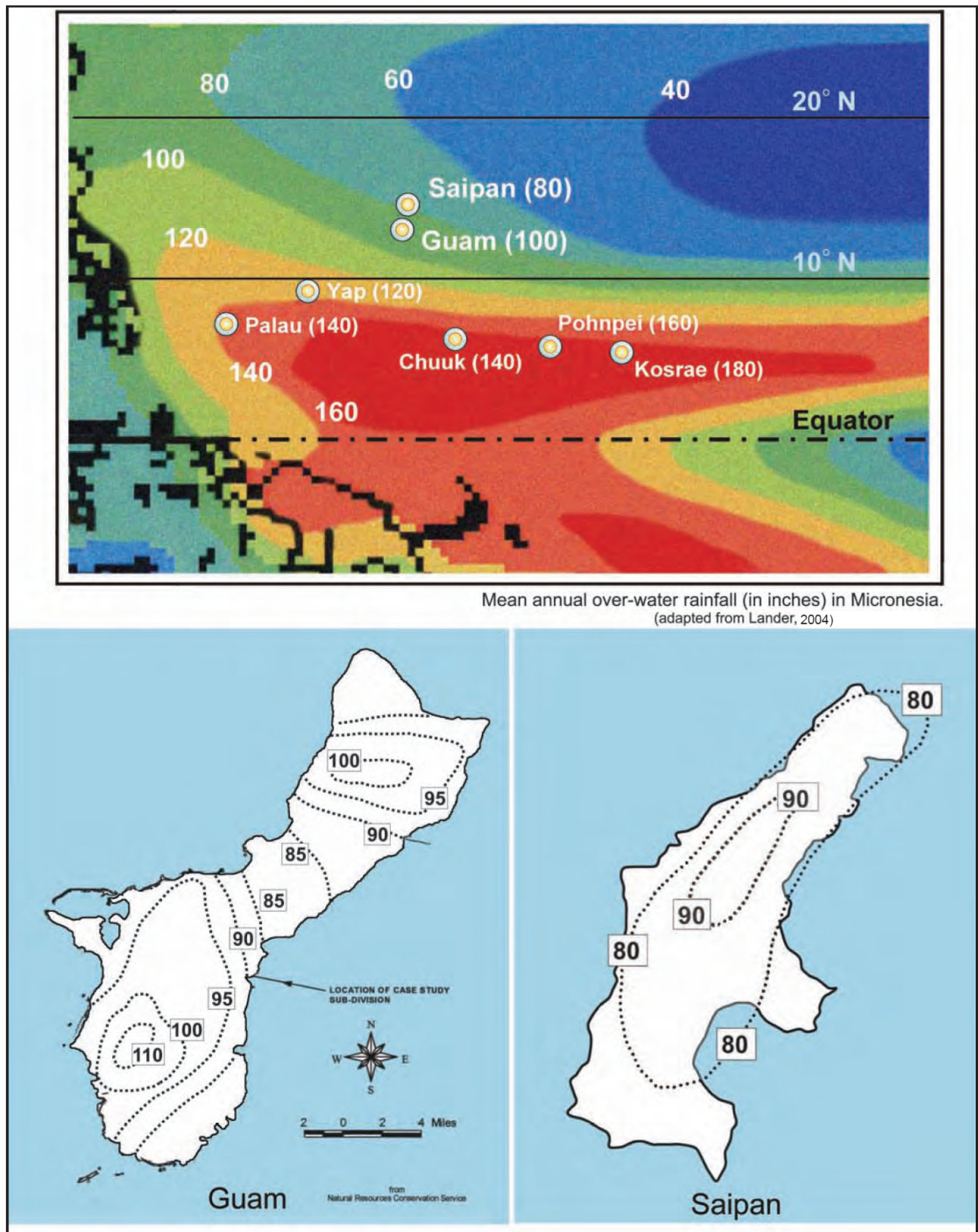

Figure 1.5 Annual precipitation values in Saipan (CNMI) and Guam

Table 1.2 below lists the annual precipitation for major locations in Guam and CNMI.

**Table 1.2 Average Annual Rainfall by Location for Guam and CNMI**

Location	Average Annual Rainfall (inches)
<b>Guam</b>	
Agat	95
Guam Int'l Airport	85
Hagatna	90
Inarajan	85
Taguac, Finegayan	100
Talofofo	95
Umatac	100

Location	Average Annual Rainfall (inches)
<b>Saipan (CNMI)</b>	
Capitol Hill	95
Marpi	85
Mt. Tagpochau	85
Saipan Int'l Airport	75
Susupe	75
<b>Tinian (CNMI)</b>	80
<b>Rota (CNMI)</b>	80



**Figure 1.6 The Uguem River flows through southern Guam (Pacific Worlds, 2003)**

**Impacts to Natural Stream Channels**

As pervious rangelands and forests are converted into less pervious urban soils or pavement, both the frequency and magnitude of storm flows increase dramatically. As a result, the bankfull event occurs two to seven times more frequently after development occurs (Leopold, 1994). In addition, the discharge associated with the original bankfull storm event can increase by up to five times (Hollis, 1975).

Storm events are ranked in terms of their statistical return frequency. For example, a storm that has a 50% chance of occurring in any given year is termed a “two-year” storm. The two-year storm has been frequently designated as the “bankfull storm,” as researchers have demonstrated that most natural stream channels have just enough capacity to handle the two-year event before spilling out into the floodplain. In Guam, about 7.0 inches of rain in a 24-hour period produces a bankfull event, and this

rainfall depth is termed the two-year design storm. Similarly, a rain event that has a 10% chance of occurring in any given year is termed a “ten-year design storm.” A ten-year storm occurs in Guam when 10.0 inches of rain fall in a 24-hour period. See **Table 2.5** for descriptions of other design storms.

Urban development increases the peak discharge rate associated with a given design storm because impervious surfaces generate greater runoff volumes and drainage systems deliver it more rapidly to a stream. The change in post-development peak discharge rates that accompany development is profiled in **Figure 1.7**.

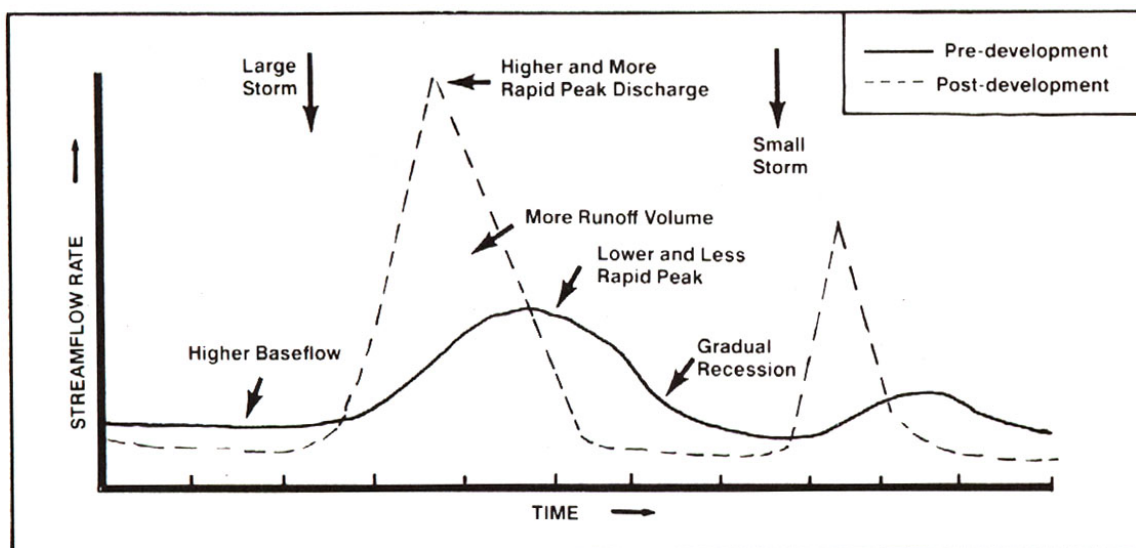

**Figure 1.7 Hydrographs Before and After Development**

### Impacts to Water Quality

Impervious surfaces accumulate pollutants windblown in from adjacent areas, leaked from vehicles, or deposited from the atmosphere. During storm events, these pollutants are quickly washed off and rapidly delivered to downstream waters. Water quality impacts are numerous, and pollutants include sediments (total suspended solids or TSS), nutrients (nitrogen and phosphorus), and pathogens (bacteria and viruses).

#### Sediment (Suspended Solids)

Sources of sediment include particles that are deposited on impervious surfaces and subsequently washed off by a storm event, as well as the erosion of streambanks and construction sites. Streambank erosion is a particularly important source of sediment, and some studies suggest that streambank erosion accounts for up to 70% of the sediment load in urban watersheds (Trimble, 1997).



**Figure 1.8 Sediment washed into a catch basin during a storm event.**

Both suspended and deposited sediments can have adverse effects on aquatic life in streams, ponds, and bays. **Figure 1.8** shows sediment being washed into an enclosed storm drain during a rain event. Turbidity resulting from this sediment can reduce light penetration for submerged aquatic vegetation critical to estuary health. In addition, the reflected energy from light reflecting off suspended sediment can increase water temperatures (Kundell and Rasmussen, 1995). Sediment can physically alter habitat by destroying the riffle-pool structure in stream systems and smothering benthic organisms. In addition, sediment transports many other pollutants to our water resources.

Sedimentation is also the most significant threat to the coral reefs around CNMI and Guam. High sediment loads can kill coral by (1) settling directly on top of corals and smothering them and (2) inhibiting photosynthesis by reducing the amount of light which gets through the water column, and (3) providing excess nutrients to the marine waters through particles that are carried with sediments.

### Nutrients

Runoff from developed land has elevated concentrations of both phosphorus and nitrogen, which can enrich streams, reservoirs, and bays (known as eutrophication). Significant sources of nitrogen and phosphorus include fertilizer, atmospheric deposition, sewage (e.g., from overflows and faulty septic systems), animal waste (both domestic and feral), organic matter, and streambank erosion. Data from mainland US suggest that lawns are a significant contributor, with concentrations as much as four times higher than other land uses, such as streets, rooftops, or driveways (Steuer et al., 1997; Waschbusch et al., 2000; Bannerman et al., 1993).



**Figure 1.9 Chickens are a familiar sight on the islands and contribute to the bacteria and nutrient loading of waterbodies**

Nutrients are of particular concern to ponds, lakes, and estuaries and are a major source of degradation in some of the islands' waters.

### Bacteria

Bacteria levels in stormwater runoff routinely exceed public health standards for water contact recreation. According to a recent analysis by the Center for Watershed Protection of 34 stormwater monitoring studies, nearly every single runoff sample exceeded bacteria standards, usually by a factor of more than 75 (Schueler and Holland, 2000). Some stormwater sources include pet waste and urban wildlife. Other sources in developed land include sanitary and combined sewer overflows, wastewater, and illicit connections to the storm drain system.

Bacteria are a leading contaminant in many of the waters of CNMI and Guam and have led to many beach closures in recent years.

## **Environmental Resource Areas and Sensitive Receptors**

Guam and CNMI contain a broad range of environmental resource areas, which are sensitive to stormwater discharges. Critical resource areas include groundwater, streams, ponds, wetlands,

beaches and coral reefs. They are impacted by both hydrologic and water quality aspects of stormwater runoff, as were discussed above.

This section explains the sensitivity of the various resource areas and evaluates their potential response to alternate stormwater management strategies and practices. Key criteria and thresholds were then developed based on these assessments to derive the resulting resource-specific integrated stormwater management program presented in this manual.

### Groundwater

Groundwater serves as the primary source of drinking water to CNMI and Guam. Groundwater is stored in highly-permeable limestone aquifers, which were originally formed as coral reefs (**Figure 1.10**). In some areas, these limestone aquifers have been uplifted (and elevated) by the underlying volcanic rocks (these are called “high-level limestone aquifers”).

The only source of groundwater recharge is precipitation, which infiltrates to the subsurface and recharges the underlying water table (the upper surface of the groundwater system). Saipan receives approximately 80-90 inches of precipitation per year, while Guam receives approximately 90-100 inches per year. A significant portion of this is lost to evapotranspiration, some is lost to surface runoff, and the remaining portion is available as “recharge” to groundwater.

In Guam, the average annual recharge rate is estimated at 35 inches/year (Barrett et al., 1982), and Saipan has an average groundwater recharge rate of 33 to 35 inches/year (USGS, 1998). The thickness of the groundwater lens is directly related to the recharge rate and to water withdrawal rates.

As land development occurs, impervious surfaces preclude the natural infiltration of this rainwater, thereby reducing the recharge rate. This results in a lowering of the water table, and a reduction of the thickness of the groundwater lens. Ultimately, development can lead to a depletion of groundwater resources, increased salt water intrusion to drinking water wells, and increased concentrations of other pollutants derived from urban runoff.

While some wells exist in the central mountainous regions (in “high-level limestone aquifers”), most of the wellfields are located in the lower limestone plateaus where the groundwater resource (referred to as the “basal aquifer”) is limited by a relatively thin groundwater lens, which actually “floats” on underlying saline groundwater due to its lighter density, and therefore is susceptible to saltwater intrusion (see **Figure 1.11**). The protection of this basal aquifer is critical to maintaining a sustainable water supply for the islands.

Water withdrawals for drinking water and irrigation also deplete the groundwater lens and result in declining water table elevations and corresponding decreases in the thickness. The Ghyben-Herzberg principle suggests that for each foot that the water table declines, the lens thickness decreases by 40 feet (based upon the 1:40 density ratio between fresh and salt water). Therefore, small reductions in recharge and the water table can significantly affect the groundwater system.

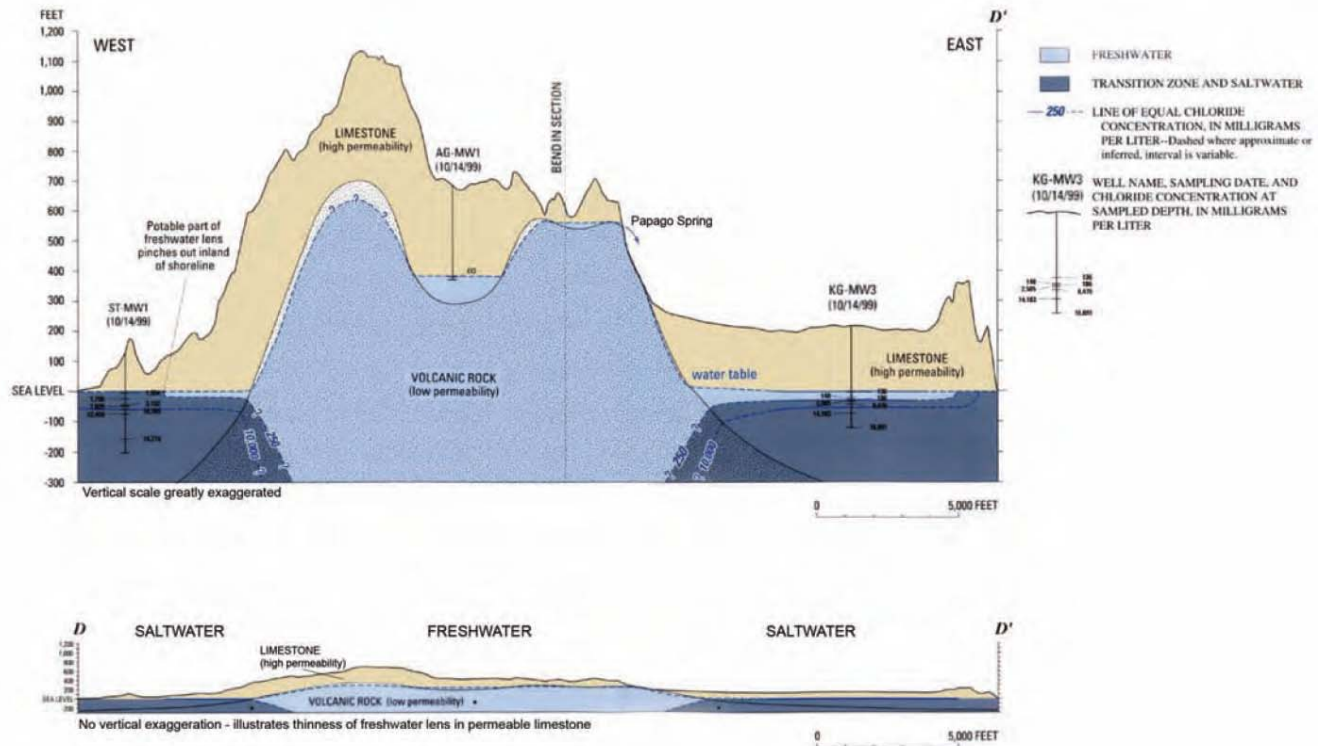
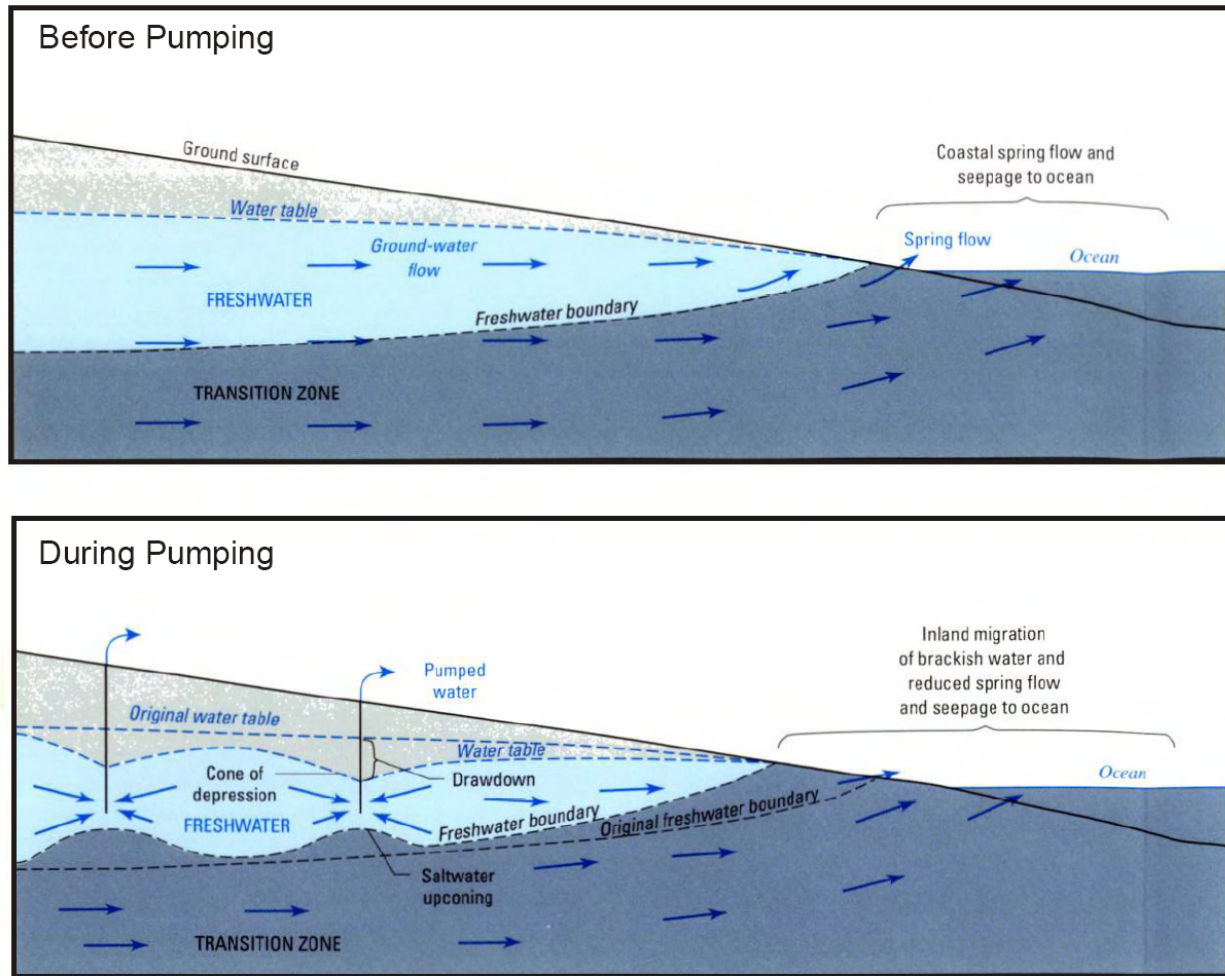

Figure 1.10 Geologic and groundwater resource characteristics of Saipan (CNMI)  
(Source: USGS, Robert L. Carruth)



**Figure 1.11** Effects of ground-water withdrawal on the potable part of the freshwater lens in a high permeability island aquifer. (Source: USGS Robert L. Carruth)



One potential remedy for this “de-watering” impact is to collect stormwater runoff and to infiltrate it to help restore (or enhance) natural recharge rates. To some degree, this already occurs in current stormwater management implementation. It is possible to collect and infiltrate enough stormwater to match the natural (pre-development) recharge rates. This may be a viable option to mitigate and compensate for other sources of water consumption and groundwater de-watering, such as groundwater withdrawals for drinking water and irrigation purposes on CNMI and Guam.

However, the infiltration of stormwater raises some important water quality issues. Stormwater is commonly degraded with a broad range of pollutants collected from the land surface or accompanying precipitation. Secondly, Guam/CNMI limestone aquifers are highly permeable and, therefore, very susceptible to contamination. Thus, depending on the land use, stormwater can require significant pre-treatment prior to infiltration to protect the quality of groundwater resources. This may be accomplished with certain stormwater BMPs that provide comprehensive treatment. Wellhead protection areas have been delineated showing the specific groundwater areas that contribute to the pumping water supply wells and require the highest level of protection to ensure a safe drinking water supply.

In addition, groundwater management zones (GMZs) have been designated on the basis of groundwater quality for Saipan. **Figure 1.12** shows the location of the three types of GMZs: Class I zones are deemed areas with the highest quality, most valuable, and most vulnerable groundwater resources; Class II zones are somewhat less valuable due to decreased lens thickness resulting in brackish water; and Class III zones are the coastal aquifers that are not potable. Guam also has two categories of groundwater, G1 and G2, which are defined as a “Resource Zone” and a “Recharge Zone.” These are vertical zones, with G2 consisting of the area above the water table where groundwater recharge occurs. G1 is the zone from which drinking water is withdrawn and must be protected from contamination. The elevations of these zones vary based on topography.

### Soils and Geology

The opportunity to infiltrate stormwater to replace natural recharge lost to impervious surfaces is dependent upon the soils and geologic characteristics of the land. Generally speaking, soils strongly influence the natural recharge characteristics associated with land in its natural state and the underlying geology provides the capability for the infiltration of stormwater at shallow depths beneath the land’s surface.

Soil surveys for both CNMI and Guam have been prepared by the U.S. Department of Agriculture, Soil Conservation Service (now known as the Natural Resources Conservation Service) (USDA, 1988 and 1989, respectively). These reports provide soil descriptions and maps. They include a narrative description of each soil type beginning at the land’s surface and proceeding downwards. The nature of the soil composition, grain size and slope determine the capability of the soil to infiltrate surface water. For this purpose, four hydrologic soil classifications are used, A, B, C and D, with A providing the most infiltration and D the least.

The amount of recharge, which naturally replenishes the underlying groundwater, is largely dependent upon precipitation and soil type (more specifically, hydrologic soil classification).



**Figure 1.12 Saipan Groundwater Management Zones (CNMI, 2004)**

To determine the potential for infiltrating stormwater in CNMI and Guam, surficial geologic information is needed in addition to soils information. This is because the hydrologic soils classification is based upon the nature of the uppermost soil “horizons” and not the underlying geologic material. Some CNMI and Guam soils become considerably more permeable at fairly shallow depths beneath the lands’ surface. For example, the “Guam” soil series, which comprises most of Northern Guam, is described as “clayey loam” in the upper 4-8 inches, underlain by very permeable limestone. Saipan’s “Chinen” soil series, which underlies many large areas of the island from Naftan through Kagman, is similarly described as a “clayey loam,” but is underlain at shallow depths by highly permeable limestone. Most stormwater infiltration practices are (or can be) constructed below the land’s surface in these higher permeability materials for quantity control (not treatment). The infiltration capacity of these materials is also linked to the surficial geology, which can be considered to be the “parent” material for the uppermost soil horizons. For more information on determining soil characteristics in the field, see **Volume II, Chapter 8**.



**Figure 1.13** Different soil horizons are clearly visible at a site in CNMI

Two major classifications of surficial geologic materials exist in CNMI and Guam: limestone and volcanic rock. Limestone is highly-permeable and capable of infiltrating relatively large quantities of water. Volcanic rocks have a significantly lower potential for infiltration and higher potential for erosion.

For the purpose of this manual, two broad classifications of the surficial geologic units have been identified: 1) limestone and beach deposits, and 2) volcanic rock. Limestone occurs as the uppermost geologic unit throughout most of Saipan and most of Northern Guam. Volcanic rock appears as the most widespread surficial geologic outcrop in Southern Guam and several, more isolated areas on Saipan.

The limestone and beach deposits provide a significant opportunity to infiltrate large quantities of stormwater to accomplish two objectives: to balance natural on-site recharge rates, and to mitigate consumptive groundwater withdrawals used for drinking water and irrigation supplies. Providing this mitigation value will help to restore the thickness of the groundwater lens and to decrease salt-water intrusion into wells. In addition, the limestone areas present the opportunity to more closely mimic the pre-development hydrology of these locations; there are no natural waterways that would have allowed runoff to discharge to the marine environment as now happens through man-made drainage systems. Instead, runoff collected in depressions and either infiltrated to the groundwater or was lost through evapotranspiration. The coral reefs, beaches, and the associated tourism industry are directly affected by these modern drainage systems that reverse the natural system, which in many of these places likely resulted in no discharge at all, except during extreme storm events.

As mentioned above, stormwater infiltration is vital to help offset the effects from current groundwater withdrawals on the freshwater lens. For example, groundwater withdrawal rates in Northern Guam are estimated to be 40 million gallons per day (MGD). Some of this groundwater is returned to the aquifer through septic systems. Assuming that 50% of this pumped water is “consumed,” the net loss from the groundwater system is approximately 20 MGD. According to an “Aquifer Management” study (Camp, Dresser & McKee, Inc., 1982), this consumptive use might result in a two-foot decline in water table elevation and a corresponding 80-foot loss in freshwater lens thickness.

The stormwater recharge criteria (see **Chapter 2**) are intended to match current natural recharge rates and supplement current drinking water withdrawals to enhance and replenish the natural groundwater lens.



**Figure 1.14** Water tumbles over volcanic formations in this stream in CNMI (Pacific Worlds, 2003)

natural stream bed elevation, the stream is intermittent. In either case, stream ecosystems are very dependent upon the maintenance of natural groundwater levels and corresponding groundwater discharges to the streams. Stream flow can also be derived from discrete springs, which are especially common in Saipan. A spring will exist where the channel intersects the limestone/volcanic boundary, and there may be no baseflow affecting the stream beyond that single point. This results in many of the “streams” in Saipan only existing for a short stretch before the water infiltrates down into the limestone, leaving dry streambeds downstream that only receive flow during large storm events.

Each stream ecosystem is adapted to its natural flow regime, which is a mixture of surface runoff events and groundwater baseflow. Stormwater management practices associated with land development within surface water stream watersheds can significantly alter the timing and rates of surface flow and groundwater discharge, thereby impacting stream ecosystems. In some cases, naturally occurring perennial streams may dry up seasonally in a developed watershed, significantly altering the habitat. Similarly, water quality impacts caused by increased nutrients and sedimentation can significantly impact streams ecosystems. Finally, streams particularly,

### Freshwater Streams, Ponds and Wetlands

There are numerous streams (perennial and intermittent), ponds, and wetlands throughout CNMI and Guam (see **Figures 1.15 and 1.16**). They provide important aquatic habitat for a broad range of fish, amphibian, mammal and bird species, and as recreational resources for humans.

Stream flow is derived from overland runoff and baseflow from groundwater, which discharges into streambeds. If baseflow is continuous throughout the year, the stream is perennial. If groundwater elevations fall below the

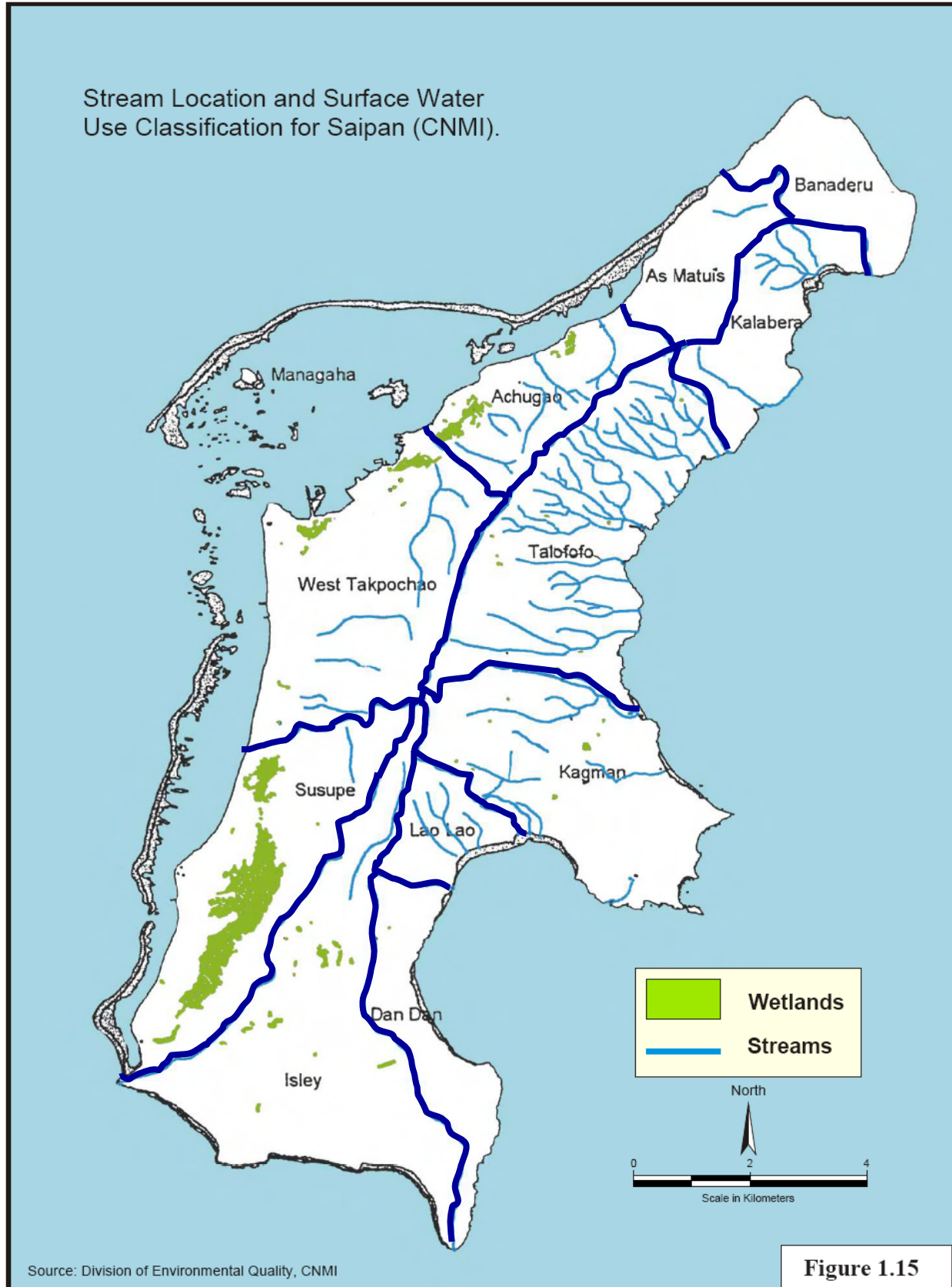



Figure 1.16

small first- and second-order streams, are especially susceptible to increased channel erosion associated with altered hydrology and land development.

Ponds provide unique habitats and are also sensitive to stormwater discharges within their watersheds. Eutrophication is a common problem in fresh water ponds, and is the result of excessive phosphorus loading, which can cause excessive weed or algal growth and ultimately can cause depleted oxygen levels, fish kills, and noxious odors. Although both phosphorus and nitrogen contribute to excessive plant growth, phosphorus is the limiting nutrient of freshwater pond environments. Common sources of phosphorus include phosphate-containing cleaners or detergents, human and animal waste, and lawn fertilizers. A water quality standard of ten parts per billion total phosphorus and orthophosphate has been established for freshwater bodies in CNMI.

Wetlands provide a broad range of habitat and recreational values. They too are susceptible to impacts from stormwater in terms of both hydrology and water quality changes. Wetlands are defined and entirely dependent upon surface and near surface hydrologic conditions (water levels to within 12 inches of the surface of the ground), which support hydrophytes (wetland vegetation) and hydric soils. Similar to the other freshwater resource areas discussed above, wetlands are very sensitive to water level changes and to alterations in water inputs. Therefore, stormwater must be managed within the watersheds to wetlands in a manner that preserves natural flow regimes. Wetlands are also susceptible to pollutant loading increases particularly phosphorus.

In the CNMI, all fresh surface waters (including wetlands) are considered to be high-quality resources (Class 1) and are protected with strict regulations to preserve its natural state with little/no degradation from man-made pollution (DEQ, Water Quality Standards, 2004). A classification system has also been designated for Guam as defined in the Guam Water Quality Standards (GEPA, 2001), which shows three categories of surface water, S1, S2, and S3. These categories are defined as “high,” “medium,” and “low,” respectively, and are protected accordingly.

### Coastal Waters

Coastal waters surround each of the fifteen CNMI islands and Guam and serve as the ultimate “discharge area” for all surface runoff. They are valuable for the support and propagation of shellfish and other marine life, conservation of coral reefs, oceanographic research, and serve as a very significant recreational resource for humans. Coastal water quality issues include eutrophication, damage to coral reefs (including sedimentation), and bacterial/viral pollution of swimming beaches. According to the “Clean Water Act 305(b)” reports for CNMI and Guam, coastal waters are most significantly impacted by sedimentation and nutrients. Sediments cause physical damage including decreased water clarity and smothering of coral and other marine resources. Nutrients (typically nitrogen for coastal environments) cause eutrophication, which results in excessive algae and weed growth, depleted dissolved oxygen levels, and foul odors.

CNMI has developed a classification system, implemented through their “Water Quality Standards,” for coastal waters. Class AA waters are considered to be very high quality and receive appropriate protection through strict numeric and narrative criteria, prohibition of direct pollutant discharges, and are “to remain in their natural pristine state as nearly as possible with an absolute minimum of pollution or alteration of water quality from any human-related source or actions.” Class A waters are considered to be slightly lower quality than Class AA, and consequently have less stringent criteria, including the allowance for zones of mixing for discharges such as those from publicly-

owned sewage treatment plants, but still receive a level of protection to maintain the use for recreational purposes and “aesthetic enjoyment.” Similarly, Guam has developed a three-tiered classification system for marine waters as defined in the Guam Water Quality Standards (GEPA, 2001). The categories include M1, M2, and M3, which are defined as “excellent,” “good,” and “fair.”

### 1.5.2 The Concept of Integrated Stormwater Management

Integrated stormwater management design involves the integration of site design practices and procedures with the design and layout of stormwater infrastructure to attain stormwater quality and quantity management goals.



**Figure 1.17** Agana Bay in Guam

The integrated stormwater management concept uses the following elements or steps:

1. Better Site Design Practices and Techniques – Protect and utilize natural features of the site to reduce runoff and pollutants. For more detail on better site design, please refer to **Volume II – Chapter 3**.
2. Unified Design Criteria for Stormwater Control Requirements – Calculate the volume of runoff to be controlled for recharge, water quality, channel protection, and overbank flood control purposes, as described below in **Chapter 2**.
3. Downstream Assessment – If necessary or desired, perform a downstream analysis to ensure that the proposed development is not adversely impacting downstream properties after the volumes calculated above have been controlled. This assessment is explained further in **Chapter 2** below.
4. Selection and Sizing of Structural Stormwater Controls and Conveyance – Structural control measures are selected using a screening process, then sized, designed and positioned in a development plan. The reader can use the matrices found in **Volume II – Chapter 2** to identify the most appropriate BMP or group of practices to use at a site.
5. Preparation of Final Site Plan – The last step in the process is the preparation of a final site plan that meets all of the construction and stormwater criteria and preserves or even enhances the water quality and natural function of the site.

The aim of these steps is to provide a process that will address the comprehensive stormwater management goals presented in **Chapter 2**, while at the same time providing ease of application for the land developer and a streamlined process for the review of a project.



The integrated design process is illustrated in **Figure 1.18**. Each concept or aspect of this process will be described in the subsequent chapters and in Volume II of the manual.

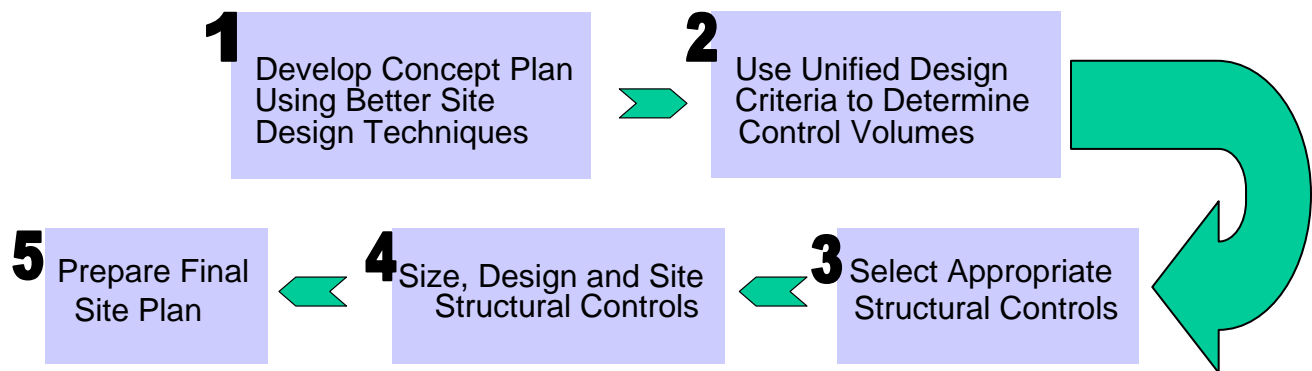

**Figure 1.18 The Integrated Stormwater Management Site Design Process**

The following principles should be kept in mind in using this process and preparing a stormwater management plan for a development site:

- Site design should utilize an integrated approach to deal with stormwater quantity, quality and protection of downstream properties and/or streambanks.

The stormwater management infrastructure for a site should be designed to integrate drainage and water quantity control, water quality protection and downstream property and channel protection. Site design should be done in unison with the design and layout of stormwater infrastructure to attain stormwater management goals. Together, the combination of better site design practices and effective infrastructure layout and design can mitigate the worst stormwater impacts of most urban developments while preserving water quality and aesthetic attractiveness.

- Stormwater management practices should strive to utilize natural drainage features and require as little maintenance as possible.

Almost all sites contain natural features that can be used to help manage and mitigate runoff from development. Features on a development site might include natural drainage patterns, depressions, permeable soils, wetlands, floodplains and undisturbed vegetated areas that can be used to reduce runoff, provide infiltration and stormwater filtering of pollutants and sediment, recycle nutrients, and maximize on-site storage of stormwater. Site design should seek to improve the effectiveness of natural systems rather than to ignore or replace them. Further, natural systems typically require low or no maintenance and will continue to function many years into the future.

- Structural stormwater controls should be implemented after site design and nonstructural options have been exhausted.

Operationally, economically, and aesthetically, conservation site design and the use of natural techniques offer significant benefits over structural stormwater controls. Therefore, all opportunities for utilizing these methods should be explored before implementing structural stormwater controls such as engineered wet ponds and sand filters.

- Structural stormwater solutions should attempt to be multi-purpose and be aesthetically integrated into a site's design.

A structural stormwater facility need not be an afterthought or ugly nuisance on a development site. A parking lot, soccer field or city plaza can serve as a temporary storage facility for stormwater. In addition, water features such as ponds and wetlands when correctly designed and integrated into a site can increase the aesthetic value of a development.

- “One size does not fit all” in terms of stormwater management solutions.

Although the basic problems of stormwater runoff and the need for its management remain the same, each site, project and watershed presents different challenges and opportunities. For instance, an infill development<sup>1</sup> in a highly urbanized town center or downtown area will require a much different set of stormwater management solutions than a low-density residential subdivision in a largely undeveloped watershed. Therefore, local stormwater management needs to take into account differences between development sites, different types of development and land use, various watershed conditions and priorities, the nature of downstream lands and waters, and community desires and preferences.

---

<sup>1</sup> An “infill development site” is defined as meeting all of the following: the site is currently predominately pervious; it is surrounded (on at least three sides) by existing development (not including roadways); the site is served by a network of existing infrastructure and does not require the extension of utility lines or new public road construction to serve the property; and the site is two (2) acres or less if residential (including single family and multi-family), commercial, industrial or multi-use.



## *2.0 Stormwater Treatment Practice Criteria and Standards*

Effective stormwater management needs to address both water quality and water quantity controls. This requires an integrated approach to applying an appropriate suite of practices to meet a range of design criteria.

It is widely recognized that in order to meet various water quality standards and classifications, some level of stormwater runoff treatment is necessary. There is conclusive water quality and biological data that show the toxic effect of untreated nonpoint source pollution. Small-sized, frequently occurring storms account for the majority of rainfall events that generate urban stormwater runoff. These frequent storms also account for a significant portion of the annual pollutant loadings. Therefore, by capturing and treating these frequently occurring smaller rainfall events, it is possible to effectively mitigate the water quality impacts of stormwater runoff.

Larger storms also have impacts associated with them from channel degradation, surface erosion, gullyng, and flood damage. These impacts can be significantly reduced by storing and releasing stormwater runoff in a gradual manner that ensures critical erosive velocities and peak discharges are not exceeded.

This chapter presents a set of criteria that are designed to meet the stormwater management and water quality goals of the CNMI and Guam for construction and post-construction conditions.

### **2.1 Construction Stormwater Treatment Criteria and Standards**

Both the CNMI and Guam have seen tremendous population growth and commercial development over the last several years. Controlling sedimentation from construction sites is a priority with regards to stormwater controls and impacts to receiving water bodies.

#### **2.1.1 General Performance Criteria**

To prevent adverse impacts from construction site runoff, the following are the general performance standards (designated as erosion and sediment control standards or E&SC Standards) for all new development and redevelopment construction sites. These narrative performance criteria shall be applied to the maximum extent practicable. If in the view of the approving authority it is impracticable or infeasible to apply one or more of the E&SC criteria to a given project, a waiver may be granted on a case-by-case basis. In addition, all sites with

disturbance over 1.0 acre are required to prepare and implement a SWPPP in accordance with the NPDES Phase II Stormwater Program<sup>1</sup>.

- E&SC Standard 1** Minimize unnecessary clearing and grading from all construction sites. Clearing and grading shall only be performed within areas needed to build the project, including structures, utilities, roads, recreational amenities, post-construction stormwater management facilities, and related infrastructure. Clearing should only be scheduled during the dry season if possible. Mass clearing during the wet season should be avoided.
- E&SC Standard 2** Rivers, streams (ephemeral, intermittent, and perennial), ponds, and wetlands shall be protected by limiting clearing within the riparian corridor (minimum of 25 feet from top of bank, more may be required for steep slopes) and applying perimeter sediment controls between disturbed areas and this riparian corridor. Existing and proposed drainage ways should also be protected by ensuring that flow velocities are non-erosive.
- E&SC Standard 3** Whenever practicable and feasible, construction shall be phased to limit disturbance to only one area of active construction at a time. Future phases shall not be disturbed until construction of prior phases is complete and the land area is stabilized.
- E&SC Standard 4** Disturbed areas shall be stabilized as soon as feasibly possible after construction is completed within a designated construction area, and in no case longer than 14 days after completion of active construction.
- E&SC Standard 5** Steep slopes shall be protected from erosion by limiting clearing of these areas in the first place or, where grading is unavoidable, by providing special techniques to prevent upland runoff from flowing down a steep slope and through immediate stabilization to prevent gulying. A steep slope is defined as any slope over 20% (5:1) in grade over a length of 50 feet.
- E&SC Standard 6** Perimeter sediment controls shall be applied to retain or filter concentrated runoff from disturbed areas to trap or retain sediment before it leaves a construction site. Upland runoff should be diverted around excavations where possible.

---

<sup>1</sup> The National Pollutant Discharge Elimination System (NPDES) was established under the Clean Water Act in 1972. Phase I addressed the most significant sources of stormwater runoff. Phase II was signed into law in 1999 and extended the coverage of the program to include more communities and smaller construction sites. To learn more about this topic, please visit the USEPA website at: <http://cfpub.epa.gov/npdes/stormwater/swphases.cfm>. The NPDES Notice of Intent (NOI) application page can be found at [http://cfpub.epa.gov/npdes/stormwater/application\\_coverage.cfm](http://cfpub.epa.gov/npdes/stormwater/application_coverage.cfm).

- E&SC Standard 7** Sediment trapping and settling devices shall be employed to trap and/or retain suspended sediments and allow time for them to settle out in cases where perimeter sediment controls (e.g., silt fence) are deemed to be ineffective in trapping suspended sediments on-site.
- E&SC Standard 8** All construction site managers (or superintendents) shall provide documentation that they have received adequate training in the application and maintenance of erosion and sediment control practices.
- E&SC Standard 9** All construction site managers must participate in a pre-construction meeting with the applicable authority to review the provisions of the erosion and sediment control plan and make any field adjustment necessary to implement the intent of the plan to minimize erosion and maximize sediment retention on-site throughout the construction process.
- E&SC Standard 10** Construction should be scheduled to minimize soil exposure in the rainy season (July 1<sup>st</sup>–Nov. 30<sup>th</sup>) and during periods of coral spawning.
- E&SC Standard 11** Erosion and sediment control practices shall be aggressively maintained throughout all phases of construction. All erosion and sediment control plans shall have an enforceable operation and maintenance agreement to ensure that practices are maintained during the construction process.

### 2.1.1.1 Designation of Stormwater “Hotspot” Land Uses

There are specific conditions where stormwater management and treatment require an added level of scrutiny. These conditions are referred to as stormwater “hotspots.” Discussion of the special considerations warranted for these applications is provided below.

A stormwater hotspot is defined as a land use or activity that generates higher concentrations of hydrocarbons, trace metals or toxins than are found in typical stormwater runoff, based on monitoring studies. If a site is designated as a hotspot, it has important implications for how stormwater is managed. First and foremost, stormwater runoff from hotspots cannot be allowed to infiltrate into groundwater without prior water quality treatment. Second, a greater level of stormwater treatment is needed at hotspot sites to prevent pollutant washoff after construction. This will involve preparing and implementing a *stormwater pollution prevention plan* (SWPPP) that involves a series of operational practices at the site that reduce the generation of pollutants from a site or prevent contact of rainfall with the pollutants. Visit the USEPA website to learn more about how to prepare a SWPPP (<http://cfpub.epa.gov/npdes/stormwater/swppp.cfm>). In addition, hotspot land uses must manage runoff in accordance with the 90% Rule<sup>1</sup> for post-construction water quality treatment. **Table 2.1** provides a list of designated hotspots for CNMI and Guam. Applicants should prepare a SWPPP for review and approval by the local authority prior to construction.

---

<sup>1</sup> 90% Rule is the more stringent criteria for water quality control and is defined in further detail in **Section 2.2.2.2**.

**Table 2.1 Classification of Stormwater Hotspot Land Uses**

<p>The following land uses and activities are considered <i>stormwater hotspots</i>:</p> <ul style="list-style-type: none"> <li>• vehicle salvage yards and recycling facilities</li> <li>• vehicle fueling stations</li> <li>• vehicle service and maintenance facilities</li> <li>• vehicle and equipment cleaning facilities</li> <li>• fleet storage areas (bus, truck, etc.)</li> <li>• industrial sites</li> <li>• marinas (service and maintenance)</li> <li>• outdoor liquid container storage</li> <li>• outdoor loading/unloading facilities</li> <li>• public works storage areas</li> <li>• facilities that generate or store hazardous materials</li> <li>• commercial container nurseries<sup>1</sup></li> <li>• waste transfer, storage, processing, and disposal sites</li> <li>• other land uses and activities designated by appropriate permitting authorities of CNMI/Guam</li> </ul>
---

### 2.1.2 Treatment Criteria

All construction site measures shall be designed to accommodate (safely convey without creating erosive conditions) the 10-year frequency storm. The 10-year frequency storm represents a large event that will generally produce significant runoff and yet has a relatively high chance of occurring in any given year (i.e., 10%). Thus, the 10-year frequency storm shall serve as the basis for channel and hydraulic design of all on-site erosion and sediment control measures.

All temporary sediment trapping devices shall be designed to retain runoff from a minimum of the 1.5" precipitation event. The 1.5-inch storm represents a frequent event that generates runoff and potential sediment load. On CNMI and Guam, the 1.5-inch event is equal to or greater than approximately 90% of precipitation events and therefore, a design criterion that requires the capture of this event will capture approximately 90% of the annual sediment load from construction sites. Thus, the 1.5-inch storm shall serve as the basis for retention design for construction site sediment trapping devices.

<sup>1</sup> A commercial container nursery is one that grows plants onsite in containers.

## 2.2 Post-construction Stormwater Treatment Standards and Criteria

This section presents general post-construction performance standards and a unified approach for sizing BMPs in Guam and the CNMI to meet groundwater recharge, pollutant removal, channel protection and flood control objectives at new development sites.

### 2.2.1 General Performance Standards for Post-construction Stormwater Management

To prevent adverse impacts of stormwater runoff, the following performance standards are recommended for all new development sites and redevelopment sites.

- Standard 1** Site designers shall strive to reduce the generation of stormwater runoff and utilize pervious areas for stormwater treatment. For development sites over 1 acre, impervious cover shall not exceed 70% of the total site area. Impervious areas are hard surfaces that prevent water infiltrating into the ground and include paved and coral surfaces such as roads, driveways, parking lots, and yards, as well as rooftops.
- Standard 2** Stormwater management shall be provided through a combination of the use of structural and non-structural practices.
- Standard 3** All stormwater runoff generated from new development shall be adequately treated prior to discharging into jurisdictional wetlands or inland and coastal waters of CNMI and Guam.
- Standard 4** Pre-development annual groundwater recharge rates and runoff rates to coastal waters shall be maintained by promoting infiltration through the use of structural and non-structural methods.
- Standard 5** For new development, structural stormwater best management practices (BMPs) shall be designed to remove 80% of the average annual post development total suspended solids (TSS) load and match or exceed pre-development infiltration rates, as possible. It is presumed that a BMP complies with this performance standard if it is:
1. sized to capture the prescribed water quality volume (WQ<sub>v</sub>),
  2. designed to match or exceed pre-development infiltration rates,
  3. designed according to the specific performance criteria outlined in this Design Manual,
  4. constructed properly, and
  5. maintained regularly.
- Standard 6** The post-development peak discharge rate frequency shall not exceed the pre-development peak discharge rate for the 25-year frequency storm event.

- Standard 7** To protect stream channels from degradation, a channel protection volume ( $Cp_v$ ) shall be provided by means of 24 hours of extended detention storage for the one-year frequency storm event.
- Standard 8** Stormwater discharges to critical areas with sensitive resources (i.e., coral reefs, swimming beaches, wellhead protection areas, designated sensitive ecosystems) will be subject to additional performance criteria, and will need to utilize or restrict certain BMPs.
- Standard 9** All BMPs shall have an enforceable operation and maintenance agreement to ensure the system functions as designed. In addition, every BMP shall have an acceptable form of water quality pretreatment.
- Standard 10** Redevelopment projects are governed by special stormwater sizing criteria depending on the amount of increase or decrease in impervious area created by the redevelopment. Redevelopment projects that reduce impervious cover (from existing conditions) by at least 40% are deemed to meet both the recharge and water quality requirements (Std # 4 and 5 above). Where site conditions prevent the reduction in impervious cover, stormwater management practices shall be implemented to provide stormwater controls for at least 40% of the site's impervious area. When a combination of impervious area reduction and stormwater management practice implementation is used for redevelopment projects, the combination of impervious area reduction and the area controlled by a stormwater management practice shall equal or exceed 40%.
- Standard 11** For sites meeting the definition of an "infill development project," the stormwater management requirements will be the same as other new development projects with the important distinctions that the applicant can meet those requirements either on-site or at an approved off-site location and that the 70% impervious cover requirement may be waived. An approved off-site location must be identified in accordance with CNMI/Guam review. The applicant must also demonstrate that there are no downstream drainage or flooding impacts as a result of not providing on-site management. The intent of this provision is to allow flexibility to meet the goals of improved water quality and channel protection to receiving waters while still promoting infill development.
- Standard 12** Certain industrial sites are required to prepare and implement a stormwater pollution prevention plan. All sites with disturbance over 1.0 acre are required to prepare and implement a SWPPP in accordance with the NPDES Phase II Stormwater Program<sup>1</sup>.

---

<sup>1</sup> The National Pollutant Discharge Elimination System (NPDES) was established under the Clean Water Act in 1972. Phase I addressed the most significant sources of stormwater runoff. Phase II was signed into law in 1999 and extended the coverage of the program to include more communities smaller construction sites. To learn more about this topic, please visit the USEPA website at: <http://cfpub.epa.gov/npdes/stormwater/swphases.cfm>.



**Standard 13** Stormwater discharges from land uses or activities with higher potential pollutant loadings, defined as hotspots (see **Section 2.1.1.1**), are required to use specific structural BMPs and pollution prevention practices. In addition, stormwater from a hotspot land use may not be recharged to groundwater without pretreatment of 100% of the water quality volume ( $WQ_v$ ) or the recharge volume ( $Re_v$ ), whichever is greater.

### 2.2.2 Treatment Criteria

The treatment criteria have been determined by a so-called unified sizing approach. This approach provides designers, reviewers, regulators, and the general public with consistent sizing rules for most projects and best management practices. The methodology is intended to manage the entire frequency of storms anticipated over the life of the stormwater practice and the associated development. Consequently, storms range from the smallest, most frequent events that produce little or no runoff, but make up the majority of individual events and are responsible for the majority of groundwater recharge and surface water quality impairment, up to the largest, very infrequent events that can cause catastrophic damage and even loss of life. While the methodology is consistent across all land uses and all receiving water types, the specific sizing requirements are different for differing geology, land use, and receiving waterbody sensitivity.

**Table 2.2** summarizes the unified sizing criteria for stormwater, while the following sections provide a more detailed description of each required sizing criterion. Justification for the selected sizing criteria can be found in the CNMI and Guam Stormwater Management Criteria submitted on July 30, 2004.

The section is organized as follows:

- 2.2.2.1 Recharge Criteria ( $Re_v$ )
- 2.2.2.2 Water Quality Criteria ( $WQ_v$ )
- 2.2.2.3 Channel Protection Criteria ( $Cp_v$ )
- 2.2.2.4 Overbank Flood Control Criteria ( $Q_{p-25}$ )

**Table 2.2 CNMI and Guam Required Unified Sizing Criteria for Stormwater Management Practices**

Criteria	Requirement										
Recharge (Re <sub>v</sub> )	<p><u>Limestone-Dominated Regions:</u></p> <p>Re<sub>v</sub> = (1.5 in) (A) (I)/12 expressed in acre-feet where:                      I = Impervious area percentage of site area (decimal)                      A = Site area (acres)</p> <p><u>Volcanic-Dominated Regions:</u></p> <p>Re<sub>v</sub> = (F) (A) (I)/12 expressed in acre-feet where:                      I = Impervious area percentage of site area (decimal)                      A = Site area (acres)</p> <table style="margin-left: auto; margin-right: auto;"> <thead> <tr> <th style="text-align: left;">Hydrologic Soil Group</th> <th style="text-align: left;">Annual Recharge Volume Factor (F)</th> </tr> </thead> <tbody> <tr> <td style="text-align: center;">A</td> <td style="text-align: center;">0.80 inches</td> </tr> <tr> <td style="text-align: center;">B</td> <td style="text-align: center;">0.50 inches</td> </tr> <tr> <td style="text-align: center;">C</td> <td style="text-align: center;">0.20 inches</td> </tr> <tr> <td style="text-align: center;">D</td> <td style="text-align: center;">0.10 inches</td> </tr> </tbody> </table> <p>Note: Stormwater runoff from hotspots should not infiltrate into groundwater without appropriate pretreatment equivalent to 100% of the water quality volume</p>	Hydrologic Soil Group	Annual Recharge Volume Factor (F)	A	0.80 inches	B	0.50 inches	C	0.20 inches	D	0.10 inches
Hydrologic Soil Group	Annual Recharge Volume Factor (F)										
A	0.80 inches										
B	0.50 inches										
C	0.20 inches										
D	0.10 inches										
Water Quality (WQ <sub>v</sub> )	<p><u>90% Rule (Discharge to High Quality Waters &amp; Hotspot Land Uses):</u></p> <p>WQ<sub>v</sub> = [(P)(A)(I)] / 12 expressed in acre-feet where:                      P = 1.5 inches<sup>1</sup>                      I = Impervious area percentage of site area (decimal)                      A = Site area (acres)</p> <p><u>80% Rule (Discharge to Moderate Quality Waters):</u></p> <p>WQ<sub>v</sub> = [(P)(A)(I)] / 12 expressed in acre-feet where:                      P = 0.8 inches<sup>1</sup>                      I = Impervious area percentage of site area (decimal)                      A = Site area (acres)</p> <p>Note: Minimum WQ<sub>v</sub> = 0.0167ft*(A) in acre-feet (or 0.2 watershed inches)</p>										
Channel Protection (Cp <sub>v</sub> )	Cp <sub>v</sub> = 24 hours extended detention of post-developed 1-year, 24-hour rainfall event.										
Overbank Flood Control (Q <sub>p-25</sub> )	Control the peak discharge from the 25-year storm to 25-year pre-development rates.										

<sup>1</sup> Precipitation is based on a rainfall frequency spectrum for a 12-hour time between storms at either the 10% exceedance frequency (discharge to high quality waters or hotspot land use) or the 20% exceedance frequency (non-hotspot land uses discharging to moderate quality waters) (Horsley Witten Group, 2004).

### 2.2.2.1 Recharge Criteria ( $Re_v$ )

The average annual predevelopment recharge rate for a site shall be preserved or augmented to maintain or increase groundwater levels which support baseflow to streams and wetlands, and to maintain overall groundwater supplies for drinking water.

Annual recharge rates on CNMI and Guam vary in large part due to the underlying geologic formations. In limestone areas (northern Guam and most of CNMI), natural recharge is in the range of approximately one-third of the annual precipitation or approximately 33 inches per year. In volcanic-dominated areas, recharge is more restricted as only a small amount of rainfall infiltrates into the usually dense underlying rock strata (Duenas and Associates, 1996).

The criterion specific to the limestone-dominated regions of CNMI and Guam requires infiltration of 1.5 inches of precipitation from all impervious surfaces. The equation is as follows:

$$Re_v = (P) (A) (I)/12$$

Where:  $Re_v$  = Recharge volume (acre-feet)  
 P = Precipitation (1.5 inches)  
 A = Site area in acres  
 I = Site imperviousness (expressed as a decimal)  
 12 = Conversion from inches to feet

This criterion would only apply to limestone-dominated recharge areas of CNMI and Guam (see **Figures 2.1 through 2.3**), except for those areas with a soil profile extending at least 3 feet below the bottom of the proposed stormwater facility. Such soil profiles must be documented by a test pit performed by a professional engineer or certified soil evaluator (see **Volume II, Chapter 8**).

In volcanic-dominated areas and areas with deep soil profiles as described above, the average annual recharge rate based on the prevailing hydrologic soil group (HSG)<sup>1</sup> present at a project site is used. The HSG can be determined from the Natural Resource Conservation Service (NRCS) Soil Surveys<sup>2</sup>. For soils described as “Urban,” designers should use a conservative assumption of HSG C. In addition, the soil characteristics at a given site should be confirmed by evaluating test pits (**Volume II, Chapter 8**). The method for the recharge criteria in volcanic areas was developed based on the amount of annual recharge that occurs as a function of HSG types. It utilizes the following predevelopment recharge percentages based on NRCS soil types for humid climates.

Hydrologic Soil Group	Annual Recharge (% of annual precipitation)
A	41%
B	27%
C	14%
D	7%

<sup>1</sup> HSG is an NRCS designation given to different soil types to reflect their relative surface permeability and infiltrative capability. Group A soils have low runoff potential and high infiltration rates. They consist chiefly of deep, well drained sands or limestone aggregates. Group B soils have moderate infiltration rates and consist chiefly of soils with fine to coarse textures. Group C soils have low infiltration rates and fine textures that impede the downward movement of water. Group D soils have high runoff potential with very low infiltration rates and consist chiefly of clay soils (NRCS TR-55, 1986).

<sup>2</sup> Please note that the HSG types listed in the CNMI Stormwater Control Handbook (1989) are incorrect. Refer to the Soil Survey for the correct values.

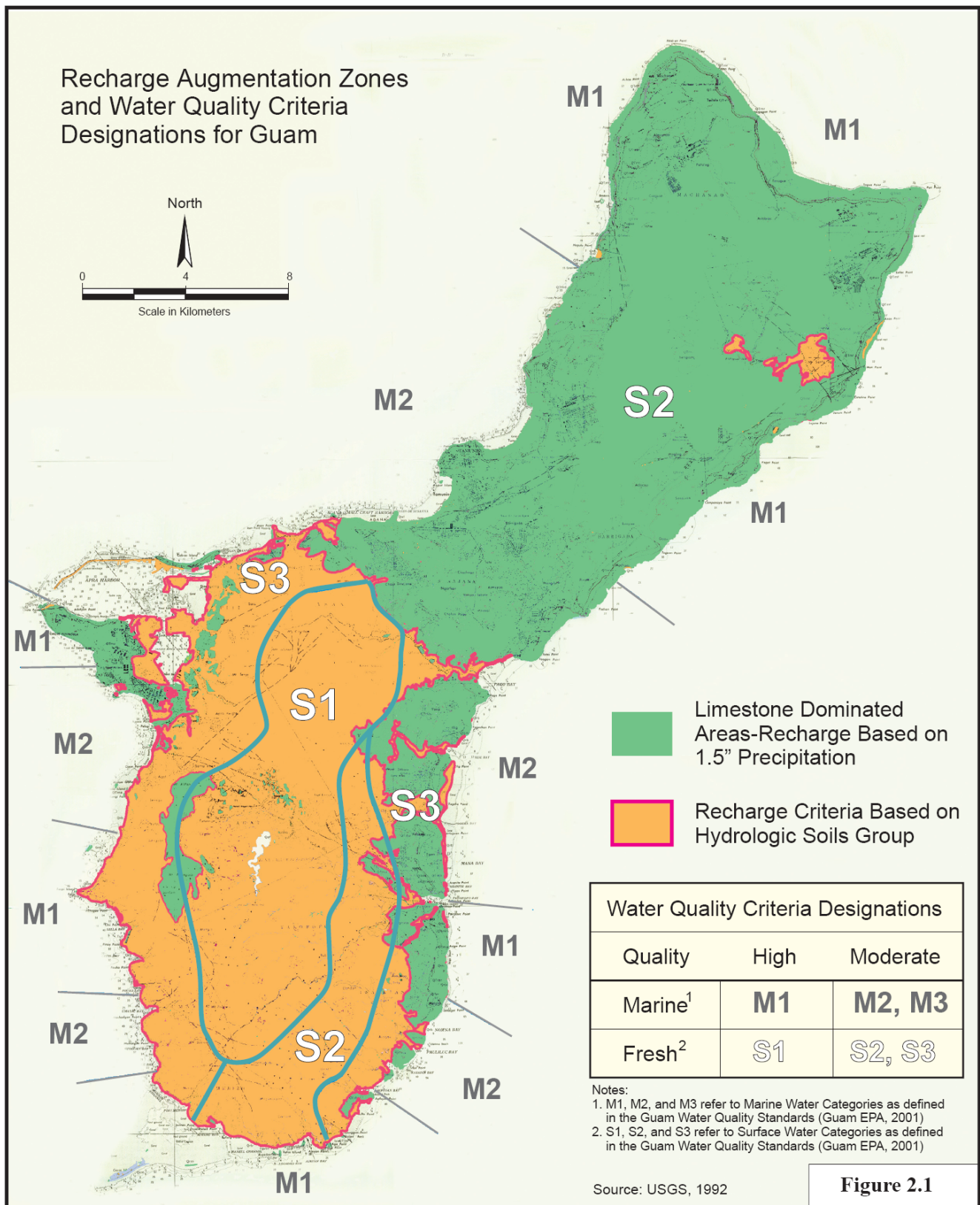

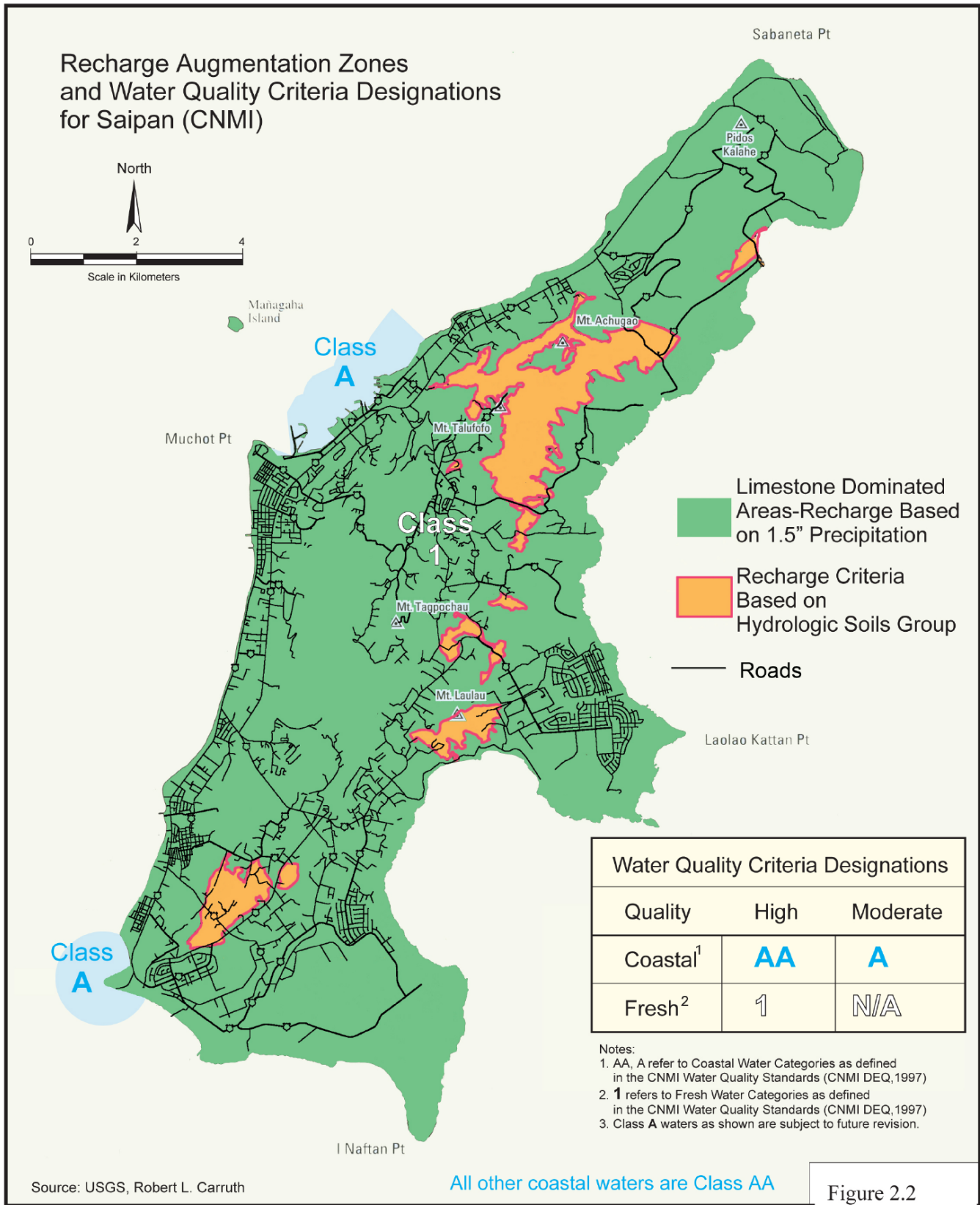

Figure 2.2

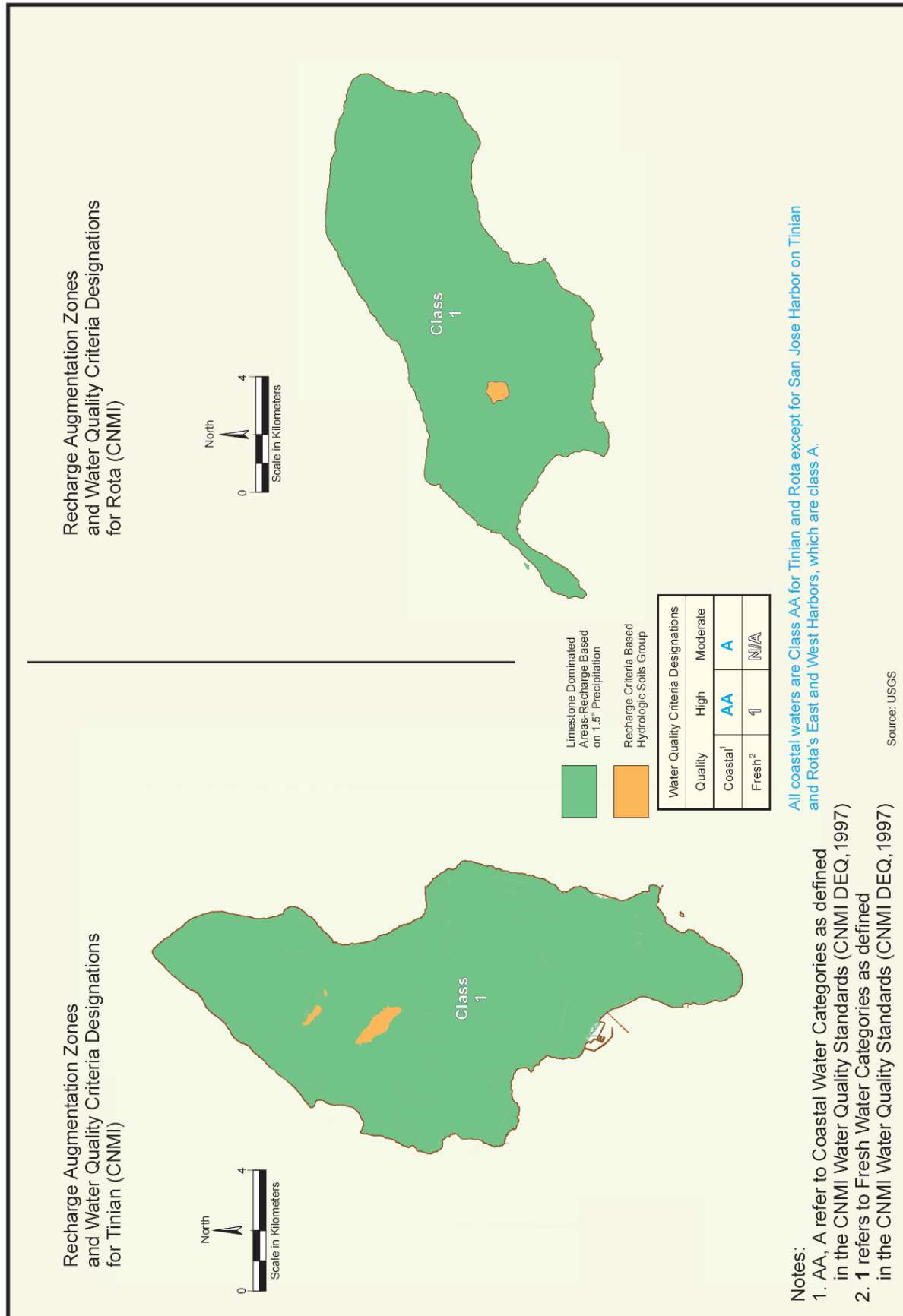

Figure 2.3 Recharge Augmentation Zones and Water Quality Criteria Designations

Based on annual rainfall and the percentages listed above, the recharge criteria for volcanic-dominated regions of CNMI and Guam are as follows:

$$Re_v = (F) (A) (I)/12$$

Where:  $Re_v$  = Recharge volume (acre-feet)  
 F = Recharge factor (inches; see below)  
 A = Site area in acres  
 I = Site imperviousness (expressed as a decimal)

Hydrologic Soil Group	Recharge Factor (F)
A	0.80
B	0.50
C	0.20
D	0.10

An example calculation using the HSG method is provided below.

*Example:* A 30-acre site is to be developed as a residential subdivision near Taguag on the Island of Guam. The impervious area for the development will be 10 acres. Half of the impervious area overlays HSG "B" soils (Akina silty clay) and half of the impervious area overlays HSG "C" soils (Pulantat clay). The recharge requirement would be calculated as follows:

For B soils = [(0.50 in) (5 ac)]/12 in/ft = 0.21 ac-ft

For C soils = [(0.20 in) (5 ac)]/12 in/ft = 0.08 ac-ft

Total recharge requirement for site = 0.21 ac-ft + 0.08 ac-ft = 0.29 ac-ft

A summary of the recharge criteria is presented in **Table 2.3** for each of the dominant geologic regions in CNMI and Guam.

**Table 2.3 Summary of Recharge Criteria for CNMI and Guam based on Surficial Geology**

Surficial Geologic Classification (see <b>Figures 2.1-2.4</b> )	Recommended Recharge Requirement
Limestone-dominated areas	1.5 inches x total site area x % impervious area <sup>1</sup>
Volcanic-dominated areas and areas with deep soil profiles <sup>2</sup>	Match natural rate based on HSG

<sup>1</sup> No adjustment of recharge precipitation value based on location of site.

<sup>2</sup> Sites with soil profiles that extend at least 3 feet below the proposed stormwater facility and documented by certified test pits (see **Volume II, Chapter 8**).

**Figure 2.4** graphically illustrates the recharge volume requirements for both limestone-dominated areas and volcanic-dominated areas as a function of site impervious cover (expressed in watershed inches<sup>1</sup>).

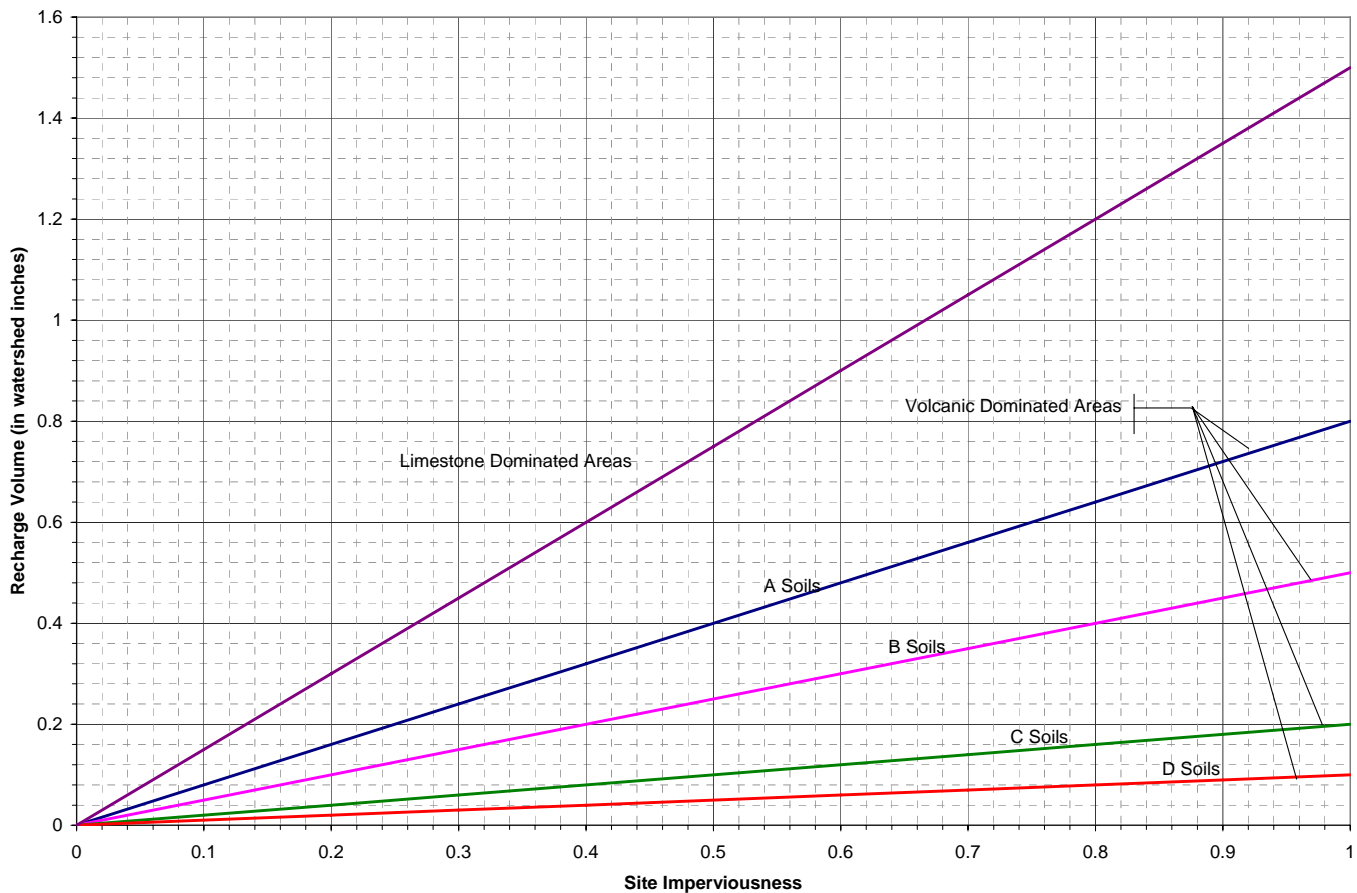

**Figure 2.4 Relationship Between Recharge Requirement and Site Impervious Cover**

The recharge volume is considered as part of the total water quality volume that must be provided at a site (i.e.,  $Re_v$  is contained within  $WQ_v$ ) and must be achieved by a structural practice (e.g., infiltration, bioretention, filters - see **Chapter 3** for a description of each practice and sample schematics). Roof runoff may be infiltrated directly without treatment and can be counted toward both the  $Re_v$  and  $WQ_v$  requirements as long as the roof area is not used for other purposes such as parking.

Some exemptions to the recharge criteria are necessary to ensure public safety, avoid unnecessary threats of groundwater contamination, and avoid common nuisance issues. Stormwater runoff from **hotspots** should not be allowed to infiltrate into groundwater without appropriate pretreatment equivalent to 100% of the water quality volume (see **Section 2.1.1.1**). The stormwater recharge requirement may be specifically waived if an applicant can demonstrate

<sup>1</sup> Recharge volume in acre-feet can be converted to watershed inches by dividing by the total site area in acres and multiplying by 12 inches/feet. Watershed inches are used to compare requirements between sites of varying sizes.



a physical limitation that would make implementation impracticable or where unusual geological features may exist such as marine clays or areas of documented slope failure.

### 2.2.2.2 Water Quality Criteria (WQ<sub>v</sub>)

The water quality volume (denoted as the WQ<sub>v</sub>) is intended to improve water quality by capturing and treating 90% of the average annual storm events for *high quality* resource areas and hotspots and 80% for land uses that drain to *moderate quality* resource areas, as described in **Section 1.5.1**, and shown in **Figures 2.1-2.3**. The WQ<sub>v</sub> is directly related to the amount of impervious cover created at a site (see **Figure 2.5**). Rainfall depths of 1.5 inches and 0.8 inches are to be used in calculating the WQ<sub>v</sub> for high and moderate quality resource areas, respectively.

The following equation can be used to determine the water quality storage volume WQ<sub>v</sub> (in acre-feet of storage):

$$WQ_v = (P) (A) (I) / 12$$

where:

- WQ<sub>v</sub> = water quality volume (in acre-feet)
- P = 90% Rainfall Event (1.5 inches) for high quality resource areas  
80% Rainfall Event (0.8 inches) for moderate quality resource areas
- A = site area in acres
- I = impervious area percentage of site area (decimal)

A minimum WQ<sub>v</sub> value of 0.0167 ft \* total area in acres (also referred to as 0.2 watershed inches) is required to fully treat the runoff from pervious surfaces on sites with low impervious cover.

**Table 2.4** lists the water quality volume requirement as a function of land use and receiving water quality. **Figures 2.1 through 2.3** depict the delineation of high quality resource areas and moderate quality resources for CNMI and Guam.

**Table 2.4 Water Quality Volume (WQ<sub>v</sub>) Requirement as a Function of Land Use and Resource Quality**

Land Use Classification	Resource Quality Designation <sup>1</sup>	
	High	Moderate
All Conventional Land Uses	1.5 in (90% Rule)	0.8 in (80% Rule)
Hotspots	1.5 in (90% Rule)	1.5 in (90% Rule)

1. Resource quality is defined as both freshwater resources and coastal resources. In CNMI, coastal waters are designated as AA (high quality) and A (moderate quality). All fresh surface waters in CNMI have been designated as Class 1 (high quality). In Guam, resource areas are designated as M1 and M2 for marine and S1, S2 and S3 for fresh waters (M1 and S1 would receive the high-quality designation). Refer to **Section 1.51** for more specific information regarding resource classification.

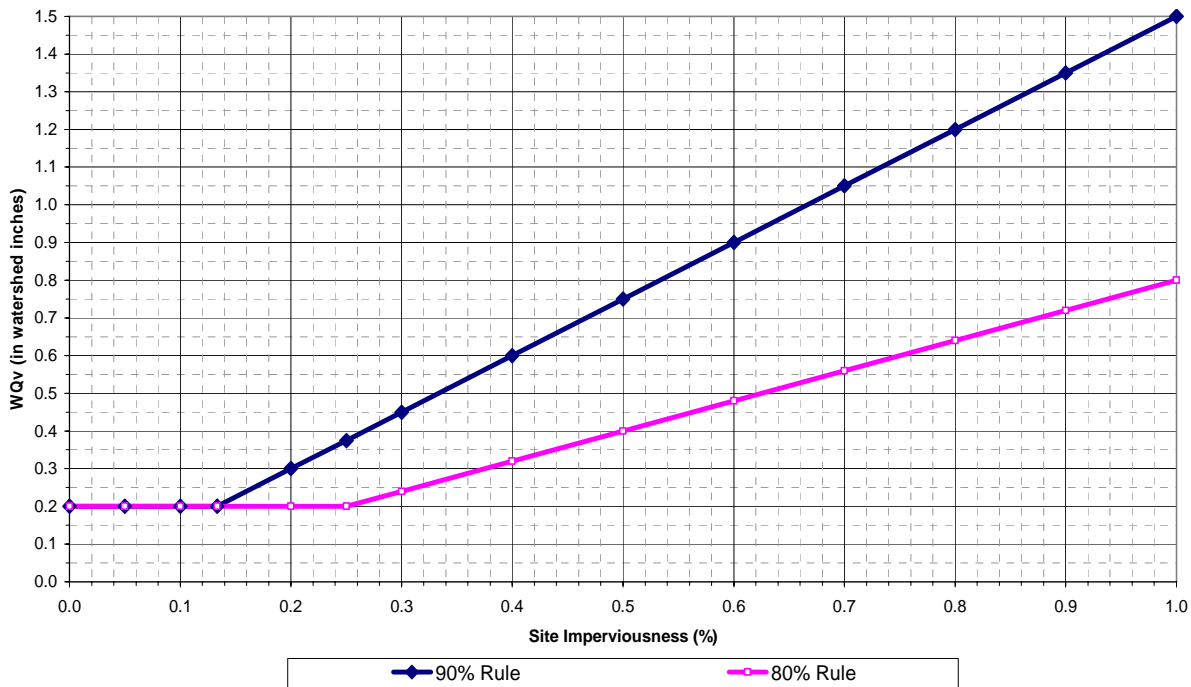

**Figure 2.5 Water Quality Volume Requirements as a Function of Site Imperviousness**

For facility sizing criteria, the basis for hydrologic and hydraulic evaluation of development sites should be as follows:

- Impervious cover is measured from the site plan and includes all impermeable surfaces (i.e., paved and coral roads, driveways and yards, parking lots, sidewalks, rooftops, patios, and decks).
- The final WQ<sub>v</sub> shall be treated by an acceptable stormwater best management practice (BMP), with consideration to the management priorities of the given receiving waters. The list of acceptable BMPs and receiving waters management criteria are presented in **Chapter 3**.
- Off-site areas shall be assessed based on their “pre-developed condition” for computing the water quality volume (i.e., treatment of only on-site areas is required). However, if an offsite area drains to a proposed BMP, flow from that area must be accounted for in the sizing of a specific practice.

**2.2.2.3 Overland Erosion and Channel Protection Criteria (C<sub>p<sub>v</sub></sub>)**

The runoff volume generated by the one-year, 24-hour rainfall shall be gradually released over a 24-hour period for overland erosion and channel protection. The objective of this criterion is to minimize overland erosion (gullyng) and downstream channel expansion and erosion that normally occur with urbanization of a watershed. The premise of this criterion is that runoff would be stored and released in such a gradual manner that critical erosive velocities would seldom be exceeded in downstream channels.

As illustrated in **Chapter 1**, annual rainfall varies across CNMI and Guam both as a function of latitude and altitude. **Table 2.5** below summarizes 24-hour rainfall events in northern Guam as

currently characterized. These values were derived from the precipitation frequency analysis from the long-term continuous meteorological observatory on northern Guam at Taguac, Finegayan, (Lat. 13°33'23"N, Long. 144°50'12"E). Rainfall records for the CNMI are currently short or incomplete, resulting in calculations of return periods of extreme rain events that are fairly crude (Lander, 2004). The lack of a consistent, long-term precipitation data record for Saipan and the other islands of the CNMI hinders the development of return period tables for the CNMI. As the rainfall data record in the CNMI becomes more extensive and reliable, then separate tables for the CNMI could be developed.

In the meantime, for locations other than northern Guam, use a ratio based on annual rainfall to derive the final design values. For example, the average rainfall at Taguac, Finegayan is approximately 100 inches per year. In coastal Saipan, the average rainfall is approximately 80 inches per year. Therefore, the design of  $C_p$  criteria for BMPs on coastal Saipan would apply a factor of 0.8 (80"/100") to the values presented in the following table. **Figure 2.6** shows the appropriate adjustment factors for various locations in CNMI and Guam.

**Table 2.5 24-hour Rainfall Events for Northern Guam (adapted from Lander, 2004)**

Recurrence Interval (years)	Exceedance Frequency (%)	Average Rainfall Amount (inches/24 hours)
1	100	3.5
2	50	7.0
10	10	10.0
25	4	20.0
50	2	27.0

For facility sizing criteria, the basis for hydrologic and hydraulic evaluation of development sites are as follows:

- The models TR-55 or TR-20 (or approved equivalent) shall be used for determining peak discharge rates.
- Rainfall depths for the one-year, 24-hour storm event are provided (3.5 inches for northern Guam).
- Off-site areas draining to proposed facility shall be modeled as “present condition” for the one-year storm event.
- The length of overland flow used in time of concentration ( $t_c$ ) calculations is limited to no more than 100 ft for post-developed conditions.
- Detention time for the one-year storm is defined as the center of mass of the inflow hydrograph and the center of mass of the outflow hydrograph.
- $C_p$  is **not required** at sites where the resulting diameter of the  $C_p$  orifice is less than 1 inch.

The treatment requirement for channel protection shall be waived for:

1. small sites (i.e., less than or equal to one acre of impervious cover).
2. direct discharges (after treatment) to a stream or river with a contributory drainage area greater than 5-square miles, large lakes or reservoirs, any coastal waters subject to tidal action, or where the development area is less than 5% of the watershed area upstream of the development site.

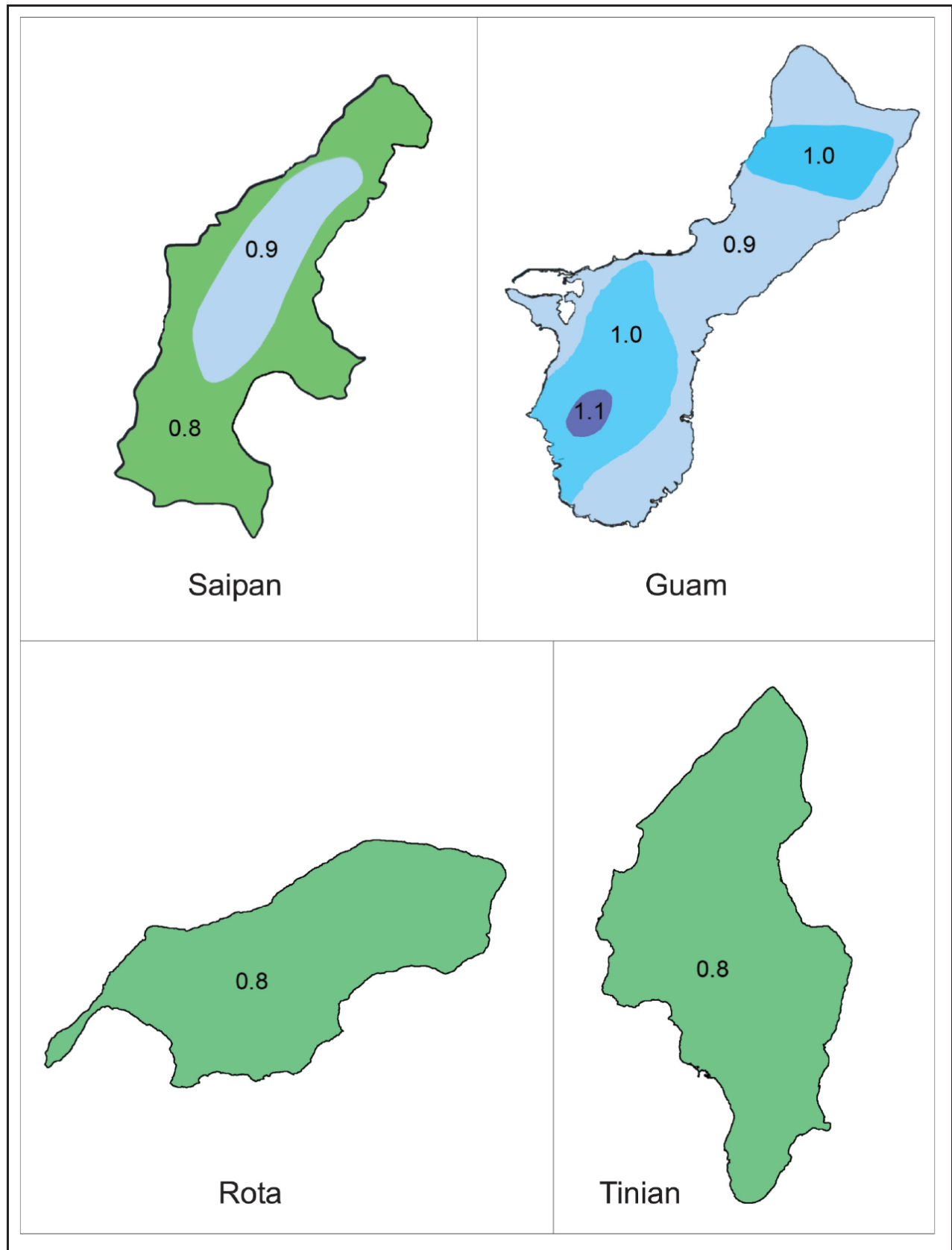

Figure 2.6 Criteria adjustment factors based on annual precipitation values (baseline precipitation 100 inches)

#### 2.2.2.4 Overbank Flood Control Criteria ( $Q_{p-25}$ )

The post-development peak discharge rate shall not exceed the pre-development peak discharge rate for the 25-year, 24-hour storm event (see **Table 2.5** above). For site locations other than northern Guam, use **Figure 2.6** to determine the appropriate adjustment factors for rainfall in CNMI and Guam.

The primary purpose of this sizing criterion is to prevent an increase in the frequency and magnitude of overbank flooding (i.e., flow events that exceed the bankfull capacity of the channel, and therefore must spill over to the floodplain). One of the key objectives of an overbank flooding requirement is to protect downstream structures (houses, businesses, culverts, bridge abutments, etc.) from increased flows and velocities from upstream development. The intent of this criterion is to prevent increased flood damage from infrequent but very large storm events, maintain the boundaries of the predevelopment floodplain, and protect the physical integrity of a stormwater management practice itself.

The following conditions apply to the overbank flood control criterion:

1. The Overbank Flood Control criterion can be waived where future development is excluded from designated floodplains downstream from a project and no existing downstream structures are within a designated floodplain<sup>1</sup>;
2. The Overbank Flood Control criterion can be waived if the site discharges directly to a large reservoir or lake, a stream or river with a contributory drainage area greater than 5 square miles, or coastal waters subject to tidal action;
3. A flood model indicates that 25-year control would not be beneficial or would exacerbate peak flows in a downstream tributary of a particular site (i.e., through coincident peaks).

For facility sizing criteria, the basis for hydrologic and hydraulic evaluation of development sites should be as follows:

- The models TR-55 and TR-20 (or approved equivalent) will be used for determining peak discharge rates.
- The standard for characterizing pre-development land use for on-site areas shall be woods, meadow, or rangeland. For agricultural land, use a curve number representing rangeland.
- Off-site areas that drain to a proposed facility should be modeled as “present condition” for peak-flow attenuation requirements.
- If an off-site area drains to a facility, an applicant must also demonstrate safe passage of the 25-year event, assuming an “ultimate buildout condition” upstream.
- The length of overland flow used in time of concentration calculations is limited to no more than 150 feet for predevelopment conditions and 100 feet for post-development conditions.

#### 2.2.3 Downstream Analysis for $Q_{p-25}$

A number of hydrologists have noted that overbank flood control approaches may not always provide full downstream control from the overbank events, due to differences in timing of individual peak discharges in the downstream portion of the watershed. Depending on the shape

---

<sup>1</sup> This potential waiver shall apply only to those projects that discharge directly to a FEMA-mapped floodplain. Projects that drain through non-floodplain conveyances (e.g. pipes, channels, ditches, etc.) prior to a mapped floodplain must meet the  $Q_{p-25}$  criterion.

and land use of a watershed, it is possible that upstream peak discharge may arrive at the same time a downstream structure is releasing its peak discharge, thus increasing the total discharge (see **Figure 2.7**). As a result of this “coincident peaks” problem, it is often necessary to evaluate conditions downstream from a site to ensure that effective overbank control is being provided.

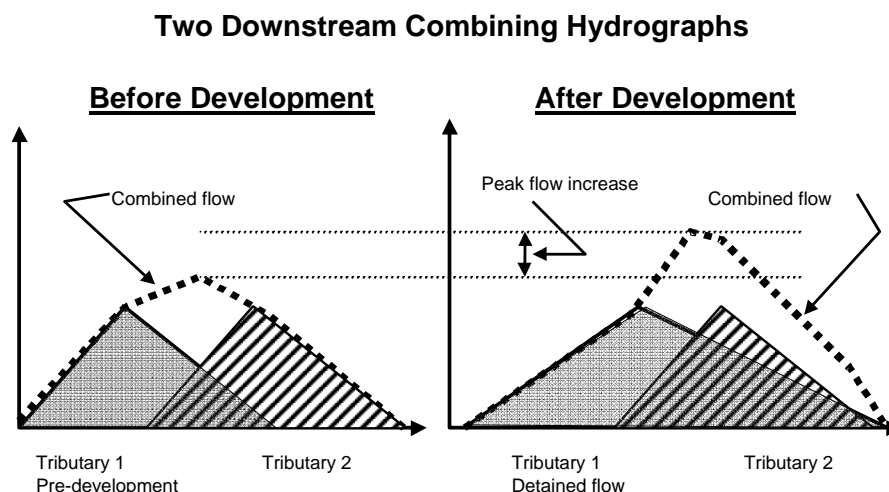

**Figure 2.7 Graphical Depictions of Coincident Peak Phenomena (Ogden, 2000)**

A downstream analysis is required for projects over 50 acres with on-site impervious cover greater than 25% or when deemed appropriate by the reviewing authority when existing conditions are already causing a problem (e.g., known drainage or flooding conditions or existing channel erosion is evident). The criteria used for the downstream analysis is referred to as the “10% rule.” Under the 10% rule, a hydrologic and hydraulic analysis is extended downstream to the point where the site represents 10% of the total drainage area. For example, a 10-acre site would be analyzed to the point downstream with a drainage area of 100 acres.

As a minimum, the analysis should include the hydrologic and hydraulic effects of all culverts and/or obstructions within the downstream channel and assess whether an increase in water surface elevations will impact existing buildings or other structures. The analysis should compute flow rates and velocities (for the overbank flood control storms) downstream to the location of the 10% rule for pre-developed conditions and proposed conditions both with and without the detention facility. If flow rates and velocities (for  $Q_{p-25}$ ) with the proposed detention facility increase by less than 5% from the pre-developed condition, and no existing structures are impacted, then no additional analysis is necessary. If the flow rates and velocities increase by more than 5%, then the designer must redesign the detention structure, evaluate the effects of no detention structure, or propose corrective actions to the impacted downstream areas. Additional investigations may be required by the approving authority on a case-by-case basis depending on the magnitude of the project, the sensitivity of the receiving water resource, or other issues such as past drainage or flooding complaints.

Special caution should be employed where the analysis shows that no detention structure is required. Stormwater designers must be able to demonstrate that runoff will not cause downstream flooding within the stream reach to the location of the 10% rule. The absence of on-

site detention for  $Q_{p-25}$  shall not be perceived to waive or eliminate groundwater recharge ( $Re_v$ ), water quality control ( $WQ_v$ ), or stream channel protection requirements ( $Cp_v$ ).

A typical downstream analysis will require a hydrologic investigation of the site area draining to a proposed detention facility and of the contributory watershed to the location of the 10% rule for the 25-year storm. A hydraulic analysis of the stream channel below the facility to the location of the 10% rule will also be necessary (e.g., a HEC-RAS water surface profile analysis). Depending on the magnitude of the impact and the specific conditions of the analysis, additional information and data may be necessary such as collecting field run topography, establishing building elevations and culvert sizes or investigating specific drainage concerns or complaints.

**2.2.4 Sample Calculations**

**Computation of Preliminary Stormwater Storage Volumes and Peak Discharges**

A large residential community is being developed near Yigo, Guam, and the layout is shown in **Figure 2.8**. This is the same site used in the design examples in **Volume II, Sections 4.1.1 – 4.1.3**. The total site consists of 44 acres with 69.1% impervious cover.

Due to the site size and localized topographic features, the site area is divided into two catchments that drain to separate stormwater treatment practices. Catchment A is comprised of 4.9 acres, and Catchment B is comprised of the remaining 39.1 acres. These sample calculations focus on Catchment B of the Mountain View Estates residential subdivision and are also used in the step-by-step stormwater wet pond design example in **Volume II, Section 4.1.1**.

The site characteristics for Catchment B are summarized below.

<u><b>Base Data – Catchment B</b></u>	<u><b>Hydrologic Data</b></u>	
Location: Yigo, Guam		
Total Drainage Area (A) = 39.1 ac	<u><b>Pre</b></u>	<u><b>Post</b></u>
Measured Impervious Area=28.1 ac; or I=28.1 ac/39.1 ac=71.9%	CN	89
Site Soils Types: 100% “B”	$t_c$ (hr)	0.20
Note: Runoff Volume = 2.0 inches for CN = 89 (see TR-55 printout, <b>Table 2.7</b> )		
CN = Curve Number		
$t_c$ = time of concentration		

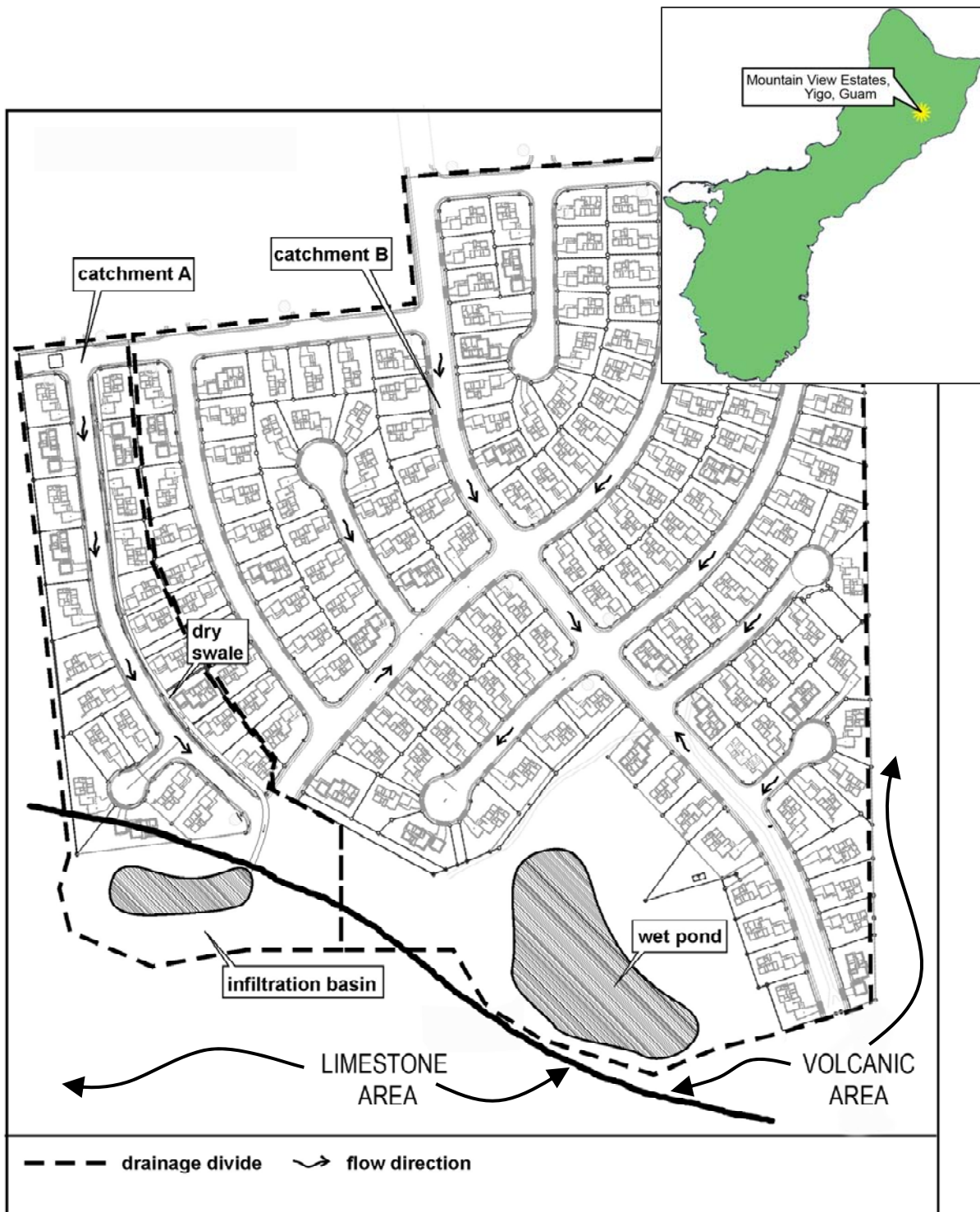

Figure 2.8 Medium Density Residential Site Plan in Guam



*Recharge Volume,  $Re_v$* 

- Compute required  $Re_v$

The site is located in a small volcanic region of the island (**Figure 2.1**) in “B” soils, so use  $F = 0.5$  multiplied by the impervious area.

$$\begin{aligned} Re_v &= [(F) (I) (A)] / 12 \\ &= [(0.5) (0.719) (39.1 \text{ ac})] (1\text{ft}/12\text{in}) \\ &= \underline{1.2 \text{ ac-ft}} \end{aligned}$$

*Water Quality Volume,  $WQ_v$* 

- Compute  $WQ_v$

Use the 90% capture rule with 1.5 inches of rainfall for high quality resource areas, and 80% capture rule with 0.8 inches for moderate quality resource areas. Consult **Figure 2.1** to determine the resource quality classification at the site. Catchment B will be discharging to an existing drainage channel in the S2 area on Guam, which falls under the 80% capture rule. (*If the project also included overflow to marine waters in the M1 area on Guam, the most stringent rule - 90% - should be applied.*)

$$\begin{aligned} WQ_v &= [(P) (I) (A)] / 12 \\ &= [(0.8 \text{ in}) (0.719) (39.1 \text{ ac})] (1\text{ft}/12\text{in}) \\ &= \underline{1.9 \text{ ac-ft}} \end{aligned}$$

Check to ensure that  $WQ_v$  is greater than minimum allowed ( $0.2 \text{ watershed inches}$  or  $0.0167 * A$ ).

$$WQ_{v\text{min}} = 0.0167\text{ft} * 39.1\text{ac} = 0.65 \text{ ac-ft} < 1.9 \text{ ac-ft, OK}$$

*Compute Stream Channel Protection Volume, ( $Cp_v$ )*

For stream channel protection, provide 24 hours of extended detention (T) for the 1-year event (3.5 in). Apply a factor based on site location (see **Figure 2.6**). This site has a factor of 1.0 for a precipitation value of 3.5 in.

Utilize SCS approach to Compute Channel Protection Storage Volume

- Initial abstraction ( $I_a$ ) for CN of 89 is 0.25: [ $I_a = (200/\text{CN} - 2)$ ]
- $I_a/P = (0.25)/ 3.5 \text{ in} = 0.071$
- $t_c = 0.20$  hours
- $q_u = 170 \text{ csm/in}$  (Exhibit 4-IA in TR-55, Type IA Storm)

Knowing  $q_u$  and T (assume 24 hrs of extended detention time), find  $q_o/q_i$  using **Figure 2.9** (MDE, 2000). [Also see methodology in **Volume II, Chapter 9**]

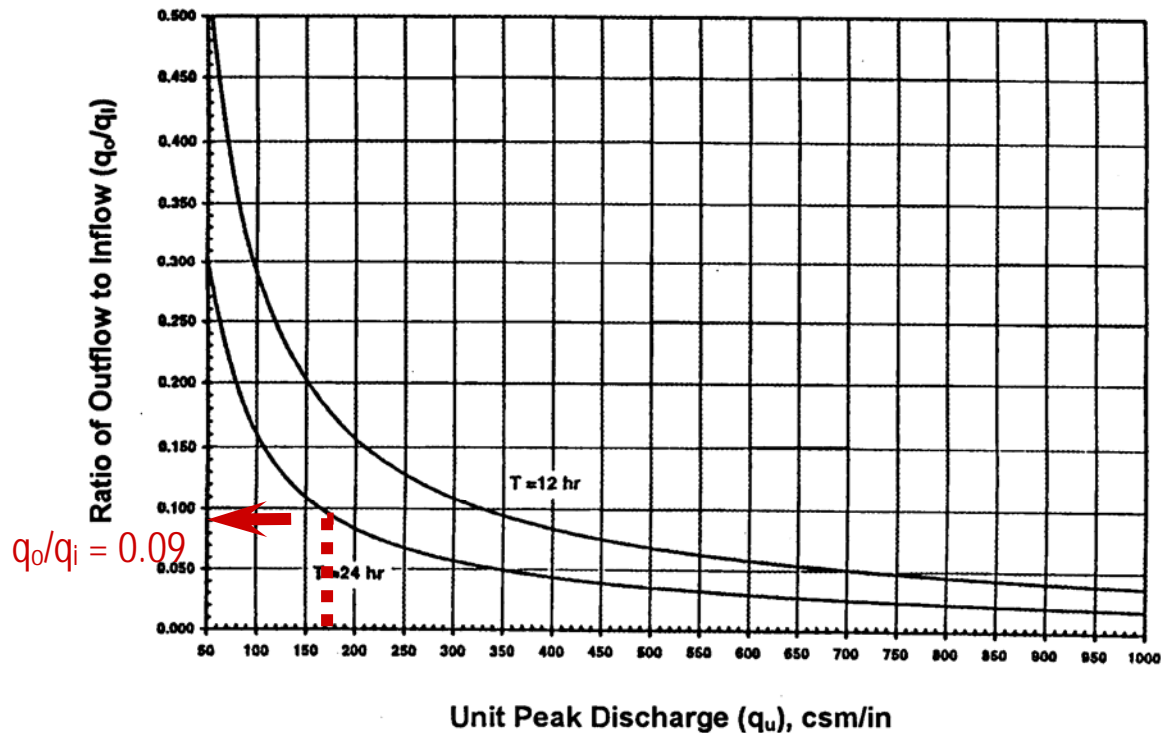

Figure 2.9 Detention Time vs. Discharge Ratios (Source: MDE, 1998)

- Peak outflow discharge/peak inflow discharge ( $q_o/q_i$ ) = 0.09
- $V_s/V_r = 0.683 - 1.43(q_o/q_i) + 1.64(q_o/q_i)^2 - 0.804(q_o/q_i)^3$  (From TR-55, Appendix F, also in **Volume II – Chapter 9**)

Where  $V_s$  equals channel protection storage ( $C_{p_v}$ ) and  $V_r$  equals the volume of runoff in watershed inches (See **Table 2.7** below, from TR-55 results).

- $V_s/V_r = 0.567$
- Therefore,  $V_s = C_{p_v} = 0.567(2.0\text{in})(1\text{ft}/12\text{in})(39.1\text{ ac}) = 3.7\text{ ac-ft } (160,952\text{ ft}^3)$

#### Define the average ED Release Rate

- The above volume, 3.7 ac-ft, is to be released over 24 hours.
- $(3.7\text{ ac-ft} \times 43,560\text{ ft}^2/\text{ac}) / (24\text{ hrs} \times 3,600\text{ sec/hr}) = 1.87\text{ cfs}$

Thus, size your stormwater facility outlet to discharge an average of 1.87 cfs in order to meet the  $C_{p_v}$  requirement.

Compute Overbank Flood Control Volume, ( $Q_{p-25}$ )

A TR-55 computer model (HydroCAD) was used to calculate peak discharges for both pre-development and post-development conditions. The inputs and results are summarized in **Tables 2.6 and 2.7.**

**Table 2.6 Mountain View Estates “B” Pre-Developed - TR-55 Output**

<b>PEAK DISCHARGE SUMMARY</b>				
<b>JOB: Mountain View Estates</b>				
<b>DRAINAGE AREA NAME:</b>	<b>PRE DEVELOPMENT</b>			
<b>COVER DESCRIPTION</b>	<b>SOIL NAME</b>	<b>GROUP A,B,C,D?</b>	<b>CN from TABLE 2-2</b>	<b>AREA (In acres)</b>
Rangeland	Akina silty clay	B	61	31.20 Ac.
Wood	Akina silty clay	B	55	7.90 Ac.
<b>AREA SUBTOTALS:</b>				<b>39.10 Ac.</b>
<b>Time of Concentration</b>	<b>Surface Cover</b>	<b>Manning 'n'</b>	<b>Flow Length Avg Velocity</b>	<b>Slope Tt (Hrs)</b>
2-Yr 24 Hr Rainfall = 7.0 In				
<b>Sheet Flow</b>	Range	'n'=0.13	50 Ft.	4.00% 0.04 Hrs
<b>Shallow Flow</b>	Short Grass Pasture		1800 Ft. 7.00 F.P.S.	3.00% 0.41 Hrs.
<b>Total Area in Acres =</b>	<b>39.10 Ac.</b>	<b>Total Sheet Flow=</b>	<b>Total Shallow Flow=</b>	
<b>Weighted CN =</b>	<b>60</b>	<b>0.04 Hrs.</b>	<b>0.41 Hrs.</b>	
<b>Time Of Concentration =</b>	<b>0.46 Hrs.</b>			
<b>RAINFALL TYPE IA</b>				
<b>STORM</b>	<b>Precipitation (P) inches</b>	<b>Runoff (Q)</b>	<b>Qp, PEAK DISCHARGE</b>	<b>TOTAL STORM Volumes</b>
<b>1 Year</b>	<b>3.5 In.</b>	<b>0.39 In.</b>	<b>1.4 CFS</b>	55,354 Cu. Ft.
<b>25 Year</b>	<b>20.0 In.</b>	<b>11.7 In.</b>	<b>122 CFS</b>	1,660,616 Cu. Ft.

**Table 2.7 Mountain View Estates “B” Post-Developed - TR-55 Output**

<b>PEAK DISCHARGE SUMMARY</b>				
<b>JOB:</b> Mountain View Estates				
<b>DRAINAGE AREA NAME:</b> POST DEVELOPMENT				
<b>COVER DESCRIPTION</b>	<b>SOIL NAME</b>	<b>GROUP A,B,C,D?</b>	<b>CN from TABLE 2-2</b>	<b>AREA (In acres)</b>
Grass	Akina silty clay	B	69	11.00 Ac.
Impervious (roads, roofs, driveways)	Akina silty clay	B	98	28.10 Ac.
<b>AREA SUBTOTALS:</b>				<b>39.10 Ac.</b>
<b>Time of Concentration</b> 2-Yr 24 Hr Rainfall = 7.0 In	<b>Surface Cover</b>	<b>Manning 'n' Pipe Diameter</b>	<b>Flow Length Avg Velocity</b>	<b>Slope Tt (Hrs)</b>
<b>Sheet Flow</b>	dense grass	'n'=0.24	50 Ft.	2.00% 0.09 Hrs
<b>Shallow Flow</b>	Short Grass Pasture		50 Ft. 7.00 F.P.S.	2.00% 0.01 Hrs.
<b>Pipe Flow a)</b>		'n'=0.013 0.8 Ft.	700 Ft.	1.00% 0.05 Hrs.
<b>b)</b>		'n'=0.013 1.3 Ft.	1251 Ft.	2.00% 0.05 Hrs.
<b>Total Area in Acres =</b>	<b>39.10 Ac.</b>	<b>Total Sheet Flow=</b>	<b>Total Shallow Flow=</b>	<b>Total Pipe Flow =</b>
<b>Weighted CN =</b>	<b>89</b>	<b>0.09 Hrs.</b>	<b>0.01 Hrs.</b>	<b>0.10 Hrs.</b>
<b>Time Of Concentration =</b>	<b>0.20 Hrs.</b>	<b>RAINFALL TYPE IA</b>		
<b>STORM</b>	<b>Precipitation (P) inches</b>	<b>Runoff (Q)</b>	<b>Qp, PEAK DISCHARGE</b>	<b>TOTAL STORM Volumes</b>
<b>1 Year</b>	<b>3.5 In.</b>	<b>2.0 In.</b>	<b>23.3 CFS</b>	<b>286,705 Cu. Ft.</b>
<b>25 Year</b>	<b>20.0 In.</b>	<b>14.9 In.</b>	<b>182 CFS</b>	<b>2,114,802 Cu. Ft.</b>

For the overbank flood control volume, size is determined using the TR-55 “Short-Cut Method,” which relates the storage volume to the required reduction in peak flow and storm inflow volume (Figure 2.10). Use the 25-year storm (20.0 in), multiplied by the adjustment factor based on site location (see Figure 2.6) – 20.0 in.

- For a  $q_{in}$  of 182 cfs (post-developed), and an allowable  $q_{out}$  of 122 cfs (pre-developed), the value of  $(q_{out})/(q_{in})$  is 0.67.
- Using Figure 2.10, and assuming a post-developed curve number of 89, the value of  $V_s/V_r = 0.14$ .

- Using a runoff volume of 2,114,802 ft<sup>3</sup> (48.6 ac-ft), the required storage (Vs) = (0.14) \* (48.6 ac-ft) = 6.81 ac-ft.

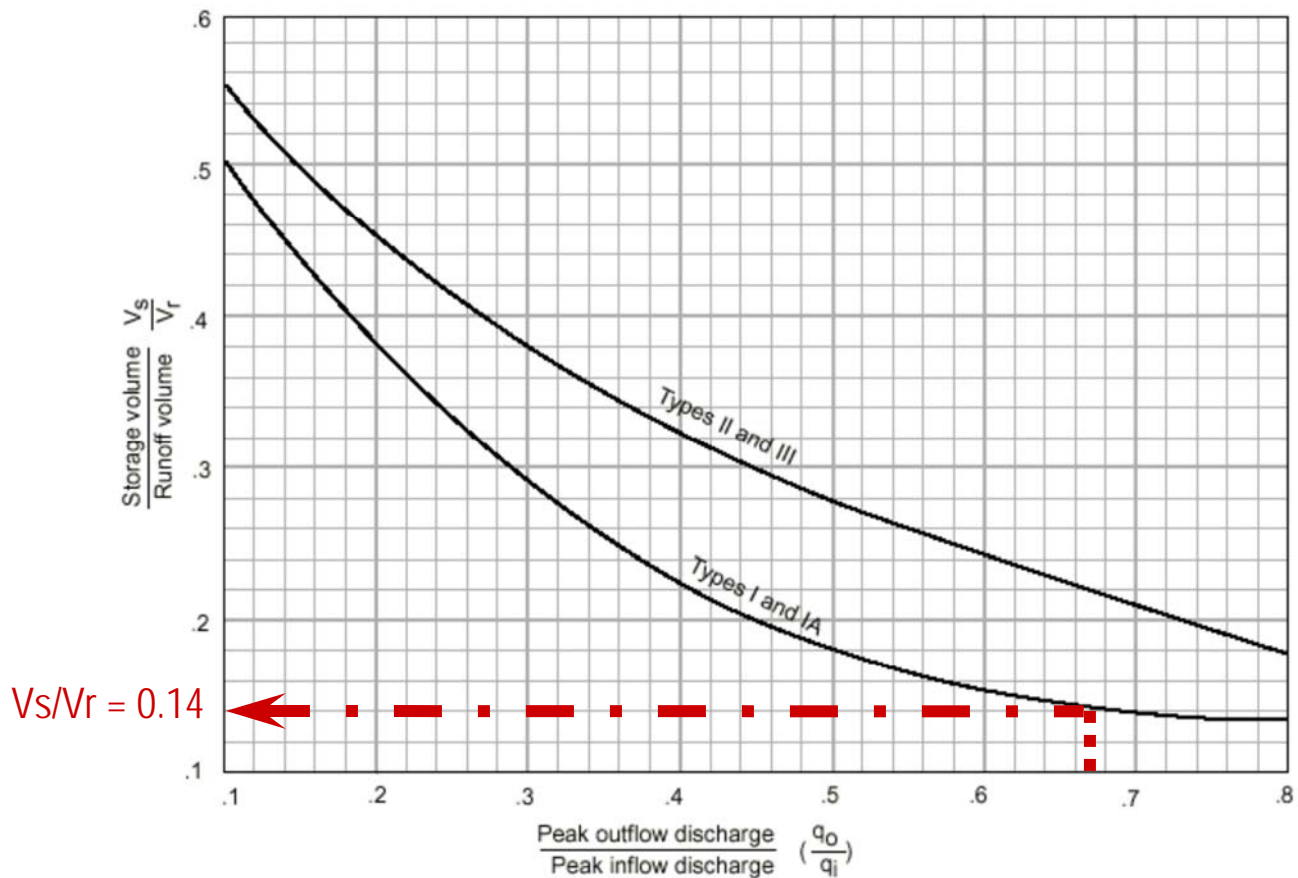

**Figure 2.10** Approximate Detention Basin routing For Rainfall Types I, IA, II, and III.  
Source: TR-55, 1986

**Table 2.8** Summary of Volume Requirements for Mountain View Estates Example

Symbol	Category	Volume Required (ac-ft)	Notes
Re <sub>v</sub>	Recharge Volume	1.2	
WQ <sub>v</sub>	Water Quality Volume	1.9	Includes Re <sub>v</sub>
Cp <sub>v</sub>	Stream Protection	3.7	Average ED release rate is 1.87 cfs over 24 hours
Q <sub>p-25</sub>	Overbank Control	6.81	

**<This page left blank intentionally>**



## ***3.0 Minimum Design Criteria for BMP Groups***

This Chapter describes the general design criteria for best management practices (BMPs) that are acceptable for meeting the Construction and Post-construction stormwater criteria listed in **Chapter 2** above.

### **3.1 Erosion and Sediment Control for Construction Sites**

This section provides documentation on the use and application of temporary control measures for managing construction site runoff, and presents the fundamentals of effective erosion and sediment control, coupled with varying levels of detail on specific practices and technical specifications. The inclusion of complete E&SC practice descriptions, details and technical specifications would require a manual in the range of 300 to 400 pages for this topic alone and is beyond the scope of this manual. Many of the E&SC guidance manuals and documents that are used across the mainland US are more than 20 years old and are based on guidance published in North Carolina and Maryland as early as the mid-1970s. While much has evolved in terms of effective E&SC in recent years, a great deal of the material from these earlier references is still widely used to control construction site sediments. This section presents the fundamentally accepted principles of effective erosion and sediment control and lists those practices that are most effective in managing construction site runoff and that can be applied on both Guam and CNMI.

Designers may still need to refer to other references such as the Guam E&SC Manual for practice details, technical specifications as well as other technical reference manuals and documents to obtain E&SC practice descriptions, details and technical specifications. The Guam manual, entitled “Guidance for Best Management Practices (BMPs) in the Preparation of a Soil Erosion and Sedimentation Control Plan,” dated May 1998, includes eight chapters, a glossary, administrative guidelines and three appendices. The main body of the manual contains 190 pages of text and figures; Appendix A, entitled “Design and Construction Considerations for Selected Control Structures and Measures” includes 202 pages of text, figures and specifications for erosion and sediment control practices. The relevant E&SC practices are also included on the reference CD accompanying this manual. Two recently published E&SC manuals for New York and Oregon can also be used to obtain practice technical specifications and details at:

<http://www.dec.state.ny.us/website/dow/toolbox/escstandards/>; and  
<http://www.deq.state.or.us/WQ/stormwater/swpescmanual.htm>.

The fundamental principles of effective erosion control can be accomplished through compliance with the 11 E&SC standards presented in **Section 2.1.1**. Project applicants, planners and designers must show compliance with each of the 11 Standards unless a waiver is granted by the approving authority. Project proponents may use a combination of temporary and/or permanent E&SC measures to ensure compliance with the 11 Standards.

In order to ensure that E&SC procedures are implemented during construction, a detailed erosion and sediment control plan must be prepared by, or under the direct supervision of, a registered Professional Engineer and presented for review and approval to the local approving authority. At a minimum, the plan must specify the following:

1. Clearing and Grading Schedule, detailing the proposed sequence of construction and proposed schedule for completion of each major element of site construction;
2. Location, details, construction specifications and maintenance requirements of proposed temporary and/or permanent structural and non-structural E&SC practices;
3. Traffic control plan for protection of practices during construction; and
4. Re-vegetation/stabilization plan clearly defining temporary and permanent vegetative stabilization for all pervious surfaces. The plan shall specify locations of temporary seeding, and/or permanent seeding. Landscaping, seed type and quantity, fertilization and mulching must be specified;

The most common temporary, permanent and vegetative stabilization practices utilized on construction sites to prevent erosion and sedimentation are listed below in **Table 3.1** and are further described with design guidance, construction details and construction specifications in **Appendix A** of this manual.

**Table 3.1 Most Common Best Management Practices for Construction Sites, Detailed in Appendix A**

<b>Temporary Structural Practices</b>	
A1:	Check Dam
A2:	Diversion Dike/Swale
A3:	Level Spreader
A4:	Perimeter Dike/Swale
A5:	Sediment Basin
A6:	Sediment Trap
A7:	Silt Fence
A8:	Stabilized Construction Entrance
A9:	Storm Drainage Inlet Protection
A10:	Turbidity Curtain
<b>Permanent Structural Practices</b>	
A11:	Vegetated and Lined Waterways
A12:	Rock Outlet Protection
<b>Vegetative Practices (Temporary and/or Permanent)</b>	
A13:	Erosion Control Blankets
A14:	Stabilization with Vegetation, Mulch, or Topsoil



**Table 3.2** presents the full suite of temporary, permanent and vegetative stabilization practices may be utilized on construction sites to prevent erosion and sedimentation. Additional practices may be used on a case-by-case basis with the consent of the local approving authority.

**Table 3.2 Full Suite of Best Management Practices for Construction Sites**

#	Practice Name	Description	Reference Manual for Details/Specifications
<b>Temporary Structural Practices</b>			
1.	Check Dam	Small temporary stone (or similar material) dams constructed across a drainage way.	<b>See Appendix A1;</b> Guam Soil E&SC Manual, Appendix A, 1998
2.	Diversion Dike	Temporary berm or ridge of compacted soil, located in such a manner as to channel water to a desired location.	<b>See Appendix A2;</b> Guam Soil E&SC Manual, Appendix A, 1998
3.	Diversion Swale	Temporary drainage-way used above and below disturbed areas to intercept runoff and divert it to a safe disposal area.	<b>See Appendix A2;</b> Guam Soil E&SC Manual, Appendix A, 1998
4.	Grade Stabilization Structure (pipe slope drain)	A temporary structure placed from the top of a slope to the bottom of a slope.	<b>See Reference CD;</b> Guam Soil E&SC Manual, Appendix A, 1998
5.	Level Spreader	A non-erosive outlet for concentrated runoff, constructed to disperse flow uniformly across a slope.	<b>See Appendix A3;</b> Guam Soil E&SC Manual, Appendix A, 1998
6.	Paved Chute or Flume	A channel lined with bituminous concrete, Portland cement, concrete or comparable non-erodible material placed to convey water from the top to the bottom of a relatively steep slope.	<b>See Reference CD;</b> Guam Soil E&SC Manual, Appendix A, 1998
7.	Perimeter Dike/Swale	A temporary ridge of soil excavated from an adjoining swale located along the perimeter of the site or disturbed area.	<b>See Appendix A4;</b> New York E&SC Manual, 2005
8.	Sediment Basin	A temporary barrier or dam constructed across a drainageway or at other suitable locations to intercept sediment laden runoff and to trap and retain the sediment.	<b>See Appendix A5;</b> Guam Soil E&SC Manual, Appendix A, 1998
9.	Sediment Tank	A sediment tank is a compartmented tank container through which sediment laden water is pumped to trap and retain the sediment.	New York E&SC Manual, 2005

#	Practice Name	Description	Reference Manual for Details/Specifications
10.	Sediment Trap	A temporary sediment control device formed by excavation and/or embankment to intercept sediment laden runoff and retain the sediment.	<b>See Appendix A6;</b> Guam Soil E&SC Manual, Appendix A, 1998
11.	Silt Fence	Temporary barrier of geotextile fabric (filter cloth) used to intercept sediment laden runoff from small drainage areas of disturbed soils.	<b>See Appendix A7;</b> Guam Soil E&SC Manual, Appendix A, 1998
12.	Stabilized Construction Entrance	Stabilized pad of aggregate underlain by filter cloth located at any point where traffic will be entering or leaving a construction site.	<b>See Appendix A8;</b> New York E&SC Manual, 2005
13.	Storm Drainage Inlet Protection	A permeable barrier installed around inlets in the form of a fence, berm or excavation around an opening, thereby reducing the sediment content of sediment-laden water.	<b>See Appendix A9;</b> New York E&SC Manual, 2005
14.	Sump Pit	A temporary pit which is constructed to trap and filter water for pumping to a suitable discharge area.	New York E&SC Manual, 2005
15.	Temporary Storm Drainage Diversion	The redirection of a storm drain line or outfall channel so that it may temporarily discharge into a sediment trapping device.	New York E&SC Manual, 2005
16.	Temporary Waterway Crossing	A temporary access waterway crossing is a structure placed across a waterway to provide access for construction purposes for a period of less than one year. Temporary access crossings shall not be utilized to maintain traffic for the general public.	New York E&SC Manual, 2005
17.	Turbidity Curtain	A flexible, impenetrable barrier used to trap sediment in water bodies. This curtain is weighted at the bottom to achieve closure while supported at the top through a flotation system.	<b>See Appendix A10;</b> New York E&SC Manual, 2005
18.	Water Bar	A ridge or ridge and channel constructed diagonally across a sloping road or utility right-of way that is subject to erosion.	New York E&SC Manual, 2005
<b>Permanent Structural Practices</b>			
19.	Diversion	A drainage way of parabolic or trapezoidal cross-section with a supporting ridge on the lower side that is constructed across the slope.	<b>See Appendix A11;</b> New York E&SC Manual, 2005
20.	Grassed Waterway	A natural or man-made channel of parabolic or trapezoidal cross-section that is below adjacent ground level and is stabilized by suitable vegetation. The flow channel is normally wide and shallow and conveys the runoff down the slope.	<b>See Appendix A11;</b> Guam Soil E&SC Manual, Appendix A, 1998

#	Practice Name	Description	Reference Manual for Details/Specifications
21.	Land Grading	Reshaping of the existing land surface in accordance with a plan as determined by engineering survey and layout.	New York E&SC Manual, 2005
22.	Lined Waterway or Outlet	A waterway or outlet with a lining of concrete, stone, or other permanent material. The lined section extends up the side slopes to the designed depth. The earth above the permanent lining may be vegetated or otherwise protected.	<b>See Appendix A11;</b> Guam Soil E&SC Manual, Appendix A, 1998
23.	Rock Outlet Protection	A section of rock protection placed at the outlet end of the culverts, conduits, or channels	<b>See Appendix A12;</b> Guam Soil E&SC Manual, Appendix A, 1998
24.	Structural Streambank Protection	Stabilization of eroding streambanks by the use of designed structural measures.	Guam Soil E&SC Manual, Appendix A, 1998; New York E&SC Manual, 2005
25.	Subsurface Drain	A conduit, such as tile, pipe, or tubing, installed beneath the ground surface, which intercepts, collects, and/or conveys drainage water.	New York E&SC Manual, 2005
<b>Vegetative Practices (Temporary and/or Permanent)</b>			
26.	Erosion Control Blankets (wood fiber, jute, synthetic fibers)	Organic fibers or synthetic materials held together with netting to cover any disturbed, denuded area subject to erosion.	<b>See Appendix A13;</b> Oregon DEQ E&SC Manual, 2005
27.	Filter Strips (Contour Strips)	Vegetative strips placed along the contour to a graded slope to filter and reduce runoff and erosion.	Oregon DEQ E&SC Manual, 2005
28.	Mulching	Applying coarse plant residue or chips, or other suitable materials, to cover the soil surface.	<b>See Appendix A14;</b> Guam Soil E&SC Manual, 1998
29.	Permanent Vegetative Covers	Establishing grasses with other forbs and/or shrubs to provide perennial vegetative cover on disturbed, denuded, steep slopes subject to erosion.	<b>See Appendix A14;</b> Guam Soil E&SC Manual, 1998
30.	Surface Roughening	Roughening a bare soil surface whether through creating horizontal grooves across a slope, stair-stepping, or tracking with construction equipment.	<b>See Reference CD;</b> Guam Soil E&SC Manual, 1998
31.	Temporary Stabilization	Providing erosion control protection to a critical area for an interim period. A critical area is any disturbed, denuded steep slope subject to erosion.	<b>See Reference CD;</b> Guam Soil E&SC Manual, 1998
32.	Topsoiling	Placement of topsoil over a prepared subsoil for the establishment of vegetation.	<b>See Appendix A14;</b> Guam Soil E&SC Manual, 1998

## 3.2 Acceptable Post-construction BMPs

This section outlines minimum design criteria for five groups of structural best management practices (BMPs) to meet water quality treatment goals. The practice groups include ponds, wetlands, infiltration practices, filtering systems and open channels. The acceptable practices in this chapter were selected based on the following criteria:

1. Can capture and treat the full water quality volume (WQ<sub>v</sub>)
2. Are capable of approximately 80% total suspended solids (TSS) removal<sup>1</sup>
3. Are capable of meeting management objectives for specific resource protection areas through elevated total phosphorus (TP), total nitrogen (TN) and/or fecal coliform bacteria (FC) removal<sup>2</sup>
4. Have acceptable longevity in the field.

This chapter also provides minimum design criteria and guidance for structural management options for stormwater quantity control (i.e., storage for C<sub>pv</sub> and Q<sub>p25</sub> and pretreatment. “Storage” practices are explicitly designed to provide stormwater detention. These practices can be used to meet channel protection and overbank flood criteria, but must be combined with other BMPs for meeting water quality and recharge criteria. Pretreatment BMPs are designed to improve water quality and enhance the effective design life of practices by consolidating sedimentation location, but cannot meet the pollutant removal targets. Pretreatment practices must be combined in a “treatment train” with other water quality BMPs to meet the water quality criteria.

For each Post-construction BMP group, design and performance criteria are provided for the following six categories:

### *Feasibility*

Identify site considerations that may restrict the use of a practice.

### *Conveyance*

Convey runoff to the practice in a manner that is safe, minimizes erosion and disruption to natural channels, and promotes filtering and infiltration.

### *Pretreatment*

Trap coarse elements before they enter the facility, thus reducing the maintenance burden and ensuring a long-lived practice.

---

<sup>1</sup> The 80% removal target is a management measure developed by EPA as part of the Coastal Zone Act Reauthorization Amendments of 1990. It was selected by EPA for the following factors: (1) removal of 80% is assumed to control heavy metals, phosphorus, and other pollutants; (2) a number of mainland U.S. states including DE, FL, TX, MA, ME, MD, and VT require/recommend TSS removal of 80% or greater for new development; and (3) data show that certain BMPs, when properly designed and maintained, can meet this performance level.

<sup>2</sup> The TP, TN and FC removal capabilities for those practices that are also capable of removing 80% TSS will dictate their application for those conditions where additional nutrient and/or bacteria removal is required.

*Treatment/Geometry*

Provide water quality treatment, through design elements that provide the maximum pollutant removal as water flows through the practice.

*Environmental/ Landscaping*

Reduce secondary environmental impacts of facilities through features that minimize disturbance of natural stream systems and comply with environmental regulations. Provide landscaping that enhances the pollutant removal and aesthetic value of the practice.

*Maintenance*

Maintain the long-term performance of the practice through regular maintenance activities, and through design elements that ease the maintenance burden.

**3.2.1 Acceptable Water Quality Practice List**

Acceptable practices are divided into **five** broad groups, including:



- **Stormwater Ponds:** Practices that have a combination of permanent pool and extended detention capable of treating the WQ<sub>v</sub>.



- **Stormwater Wetlands:** Practices that include significant shallow marsh areas, and may also incorporate small permanent pools or extended detention storage to achieve the full WQ<sub>v</sub>.



- **Infiltration Practices** Practices that capture and temporarily store the WQ<sub>v</sub> before allowing it to infiltrate into the B and/or C soil horizons. Runoff that discharges directly into limestone areas requires treatment via another approved management practice.



- **Filtering Practices** Practices that capture and temporarily store the  $WQ_v$  before passing it through a filter bed of sand, organic matter, soil, or other media.



- **Open Channel Practices** Practices explicitly designed to capture and treat the full  $WQ_v$  within dry or wet cells formed by check dams or other means, or within the channel itself through a slow velocity and relatively long residence time.

**Table 3.3** below lists and describes the BMPs in each of the groups that are acceptable to capture and treat the full  $WQ_v$ .

**Table 3.3 List of BMPs Acceptable for Water Quality**

Group	Practice	Description
Ponds	Micropool <sup>1</sup> Extended Detention Pond	Pond that treats the majority of the water quality volume through extended detention <sup>2</sup> , and incorporates a micropool at the outlet of the pond to prevent sediment resuspension.
	Wet Pond	Pond that provides storage for the entire water quality volume in the permanent pool.
	Wet Extended Detention Pond	Pond that treats a portion of the water quality volume by detaining storm flows above the permanent pool for a specified minimum detention time.
Wetland	Shallow Marsh	A wetland that provides water quality treatment primarily in wet shallow marsh.
	Extended Detention Wetland	A wetland system that provides a portion of the water quality volume by detaining storm flows above the marsh surface.
	Pocket Wetland/Pond	A wetland or pond design adapted for treatment of runoff from small drainage areas, which has little or no baseflow available to maintain water elevations and relies on groundwater inputs to maintain a permanent pool.

<sup>1</sup> Micropool is the term to define a small permanent pool 4-8 feet deep, typically with a minimum storage of 0.1 inches per impervious acre of drainage.

<sup>2</sup> Extended detention involves providing temporary storage above the permanent pool or micropool for at least a portion of the  $WQ_v$  that is released over a specified period of time (i.e., 24 hours).

Group	Practice	Description
Infiltration	Infiltration Trenches/Chambers	An infiltration practice that stores the water quality volume in the void spaces of a limestone aggregate trench or within an open chamber before it is infiltrated into underlying soils within the B or C soil horizons.
	Infiltration Basin	An infiltration practice that stores the water quality volume in a shallow surface depression before it is infiltrated into the underlying soils within the B or C soil horizons.
Filtering Practices	Sand Filter	A filtering practice that treats stormwater by settling out larger particles in a sediment chamber, and then filtering stormwater through a surface, underground, or perimeter sand matrix.
	Organic Filter	A filtering practice that uses an organic medium such as compost in the filter, or incorporates organic material in addition to sand (e.g., peat/sand mixture).
	Bioretention	A shallow depression that treats stormwater as it flows through a soil matrix, and is returned to the storm drain system, or infiltrated into underlying soils or substratum.
Open Channels	Dry Swale	An open vegetated channel or depression explicitly designed to detain and promote filtration of stormwater runoff into an underlying fabricated soil matrix.
	Wet Swale	An open vegetated channel or depression designed to retain water or intercept groundwater for water quality treatment.

See **Volume II-Chapter 2** for presumed pollutant removals of the practice groups as guidance on appropriate BMP selection.

### 3.2.2 Structural Practices that Meet Groundwater Recharge ( $Re_v$ ) Requirements

The recharge volume is considered as part of the total water quality volume that must be provided at a site (i.e.,  $Re_v$  is contained within  $WQ_v$ ) and can be achieved either by a structural practice (e.g., infiltration, bioretention, filters), a non-structural practice (filtration of sheet flow from disconnected impervious surfaces), or a combination of both. The BMPs from **Table 3.3** that are acceptable for recharge are as follows:

- Infiltration trench/chamber
- Infiltration basin
- Filters (if designed as exfilters)
- Bioretention
- Dry swale

### 3.2.3 Structural Practices That Meet Water Quantity ( $C_{p_v}/Q_{p-25}$ ) Requirements and Pre-treatment Functions

Several practices are not recommended for providing the target water quality treatment (i.e., 80% TSS removal) as “stand alone” practices. Many of these practices have little monitoring data, or available data suggest poor pollutant removal capabilities. Some of these practices, such as dry ponds and underground storage vaults, can be used to meet  $C_{p_v}$  and  $Q_{p-25}$  requirements, while others can often be incorporated into a BMP design as pretreatment devices, to treat a small portion of a site, or to meet the recharge criterion. The following practices do not meet the water quality treatment target, but may have some applicability in a site design in conjunction with recommended practices:

*For channel protection and flood control requirements:*

- Dry Ponds/Underground Vaults/On-Line Storage in the Storm Drain Network (Designed for Flood Control)
- Infiltration Chambers without filtration through the B or C soil horizons

*For pretreatment:*

- Filter Strips
- Grass Channels
- Deep Sump Catch Basins and Catch Basin Inserts
- Oil/Grit Separators and Hydrodynamic Structures

Limited design guidance and specifications are provided in this manual for these practices. In addition, a number of proprietary technologies have been developed to provide water quality treatment. Some of these have been monitored by independent sources with mixed results. The U.S. EPA and the U.S. NRCS have developed a joint manual and website describing these technologies. Individual fact sheets can be downloaded from the following source ([http://www.epa.gov/NE/assistance/ceit\\_iti/tech\\_cos/stor.html](http://www.epa.gov/NE/assistance/ceit_iti/tech_cos/stor.html)).

### 3.2.4 Minimum Design Criteria for BMPs

This section presents two types of criteria for the BMPs listed above—required design elements and design guidelines. Required design elements are features that shall be used in all applications. Design guidelines are features that enhance practice performance, but may not be necessary for all applications. A fact sheet at the back of each section highlights the required elements for each practice group.



### 3.2.4.1 Stormwater Ponds

Stormwater ponds are practices that have either a permanent pool of water, or a combination of a permanent pool and extended detention, and some elements of a shallow marsh equivalent to the entire  $WQ_v$ . Ponds can be created by either excavating an existing depression or creating embankments.\* Three design variants include:

- P-1            Micropool Extended Detention Pond            (Figure 3.1)
- P-2            Wet Pond            (Figure 3.2)
- P-3            Wet Extended Detention Pond            (Figure 3.3)

#### Treatment Suitability:

All stormwater pond design variations can be used to provide channel protection volume ( $Cp_v$ ) as well as overbank flood attenuation ( $Q_{p-25}$ ). Dry extended detention ponds without a permanent pool are not considered an acceptable option for meeting water quality treatment goals; however, they may be appropriate to meet water quantity criteria (see **Section 3.2.5**).

#### \*NOTE:

Any practice that creates an embankment is required to follow the guidance presented in the *Embankment Standards and Specifications* (**Volume II, Chapter 6**).

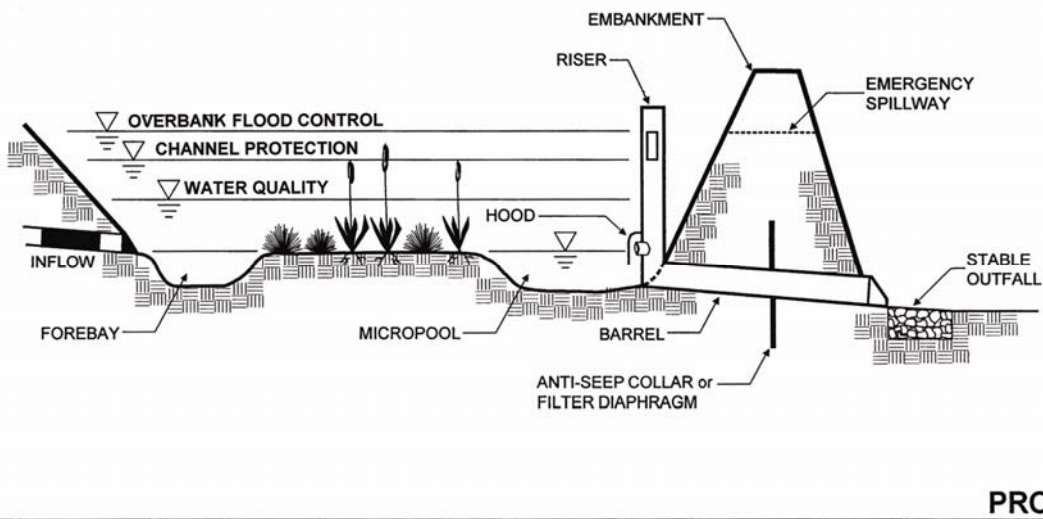
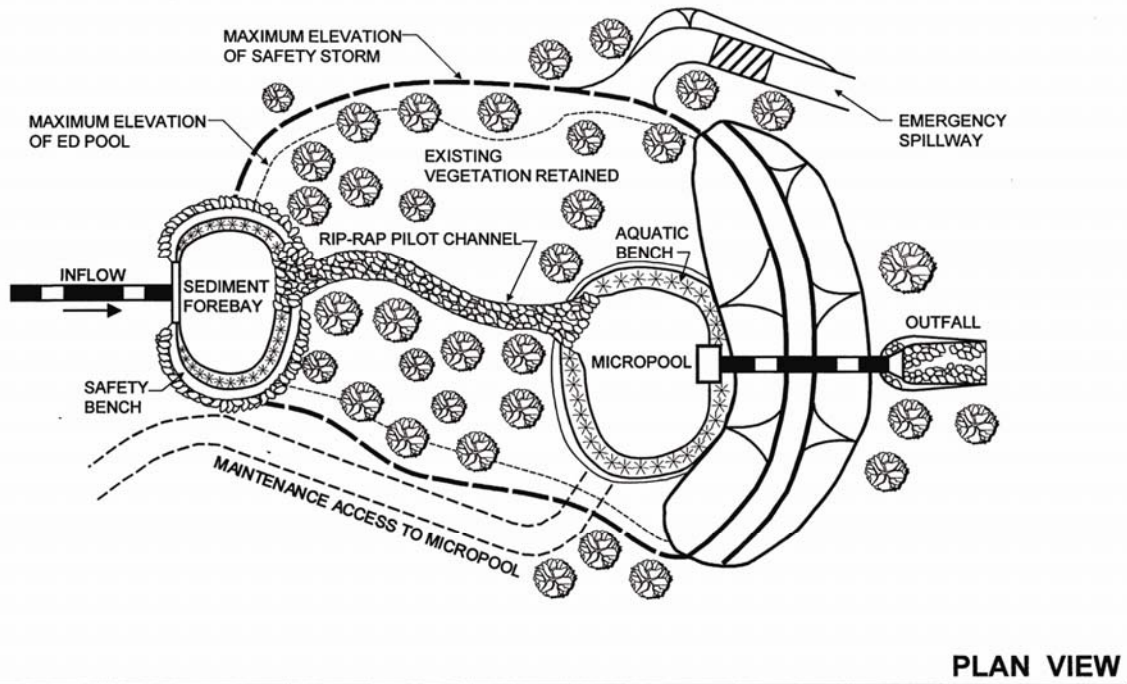

**Figure 3.1 Micropool Extended Detention Pond (P-1)**

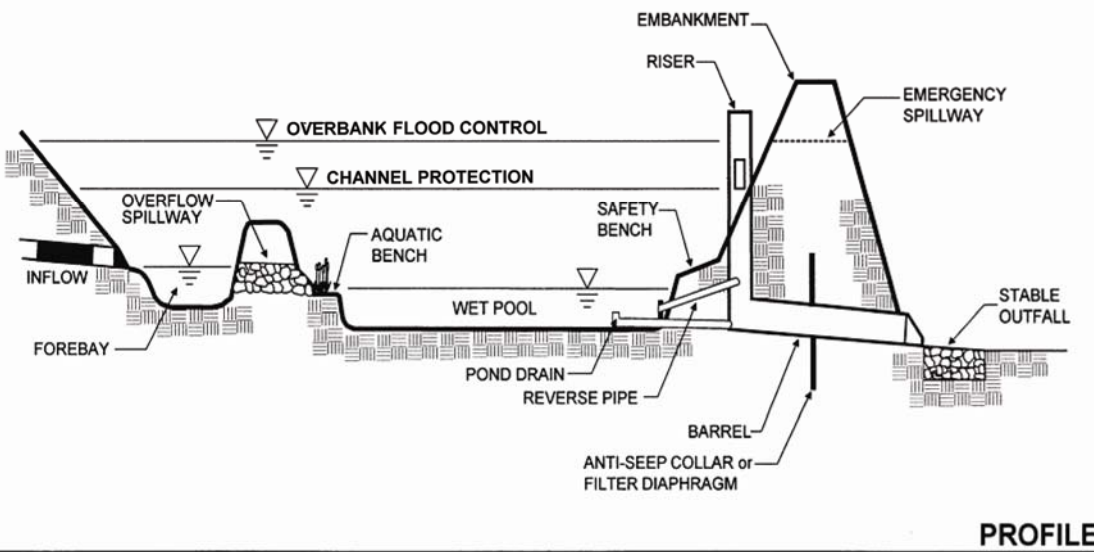
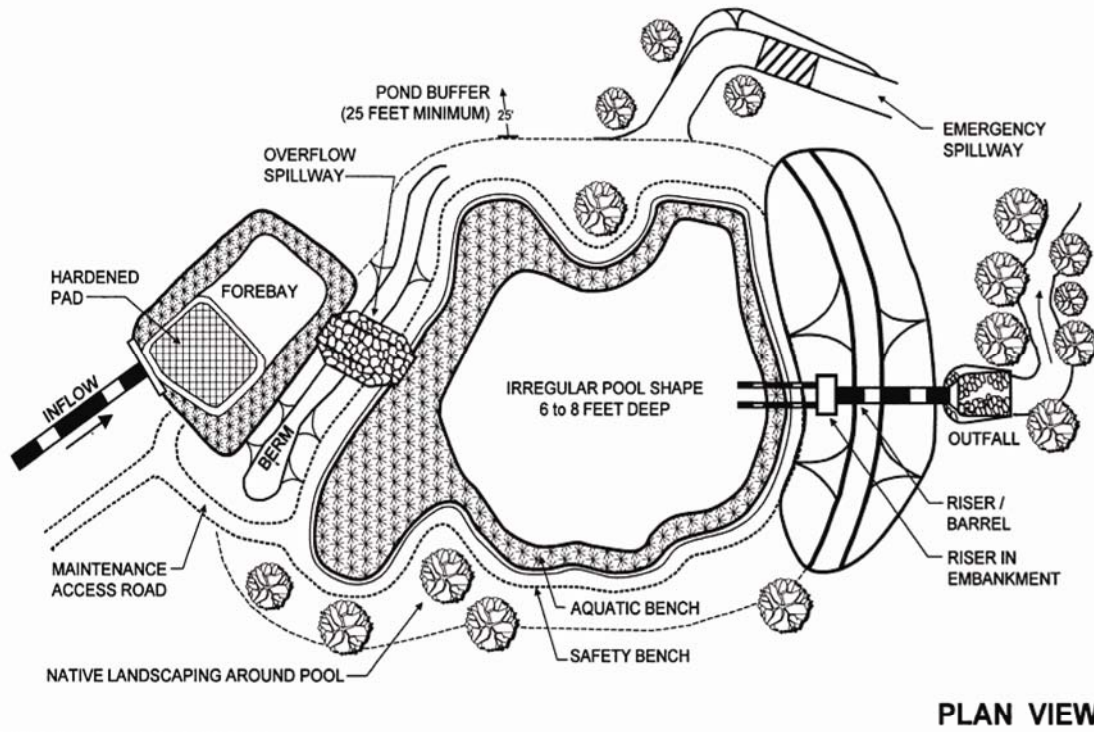

Figure 3.2 Wet Pond (P-2)

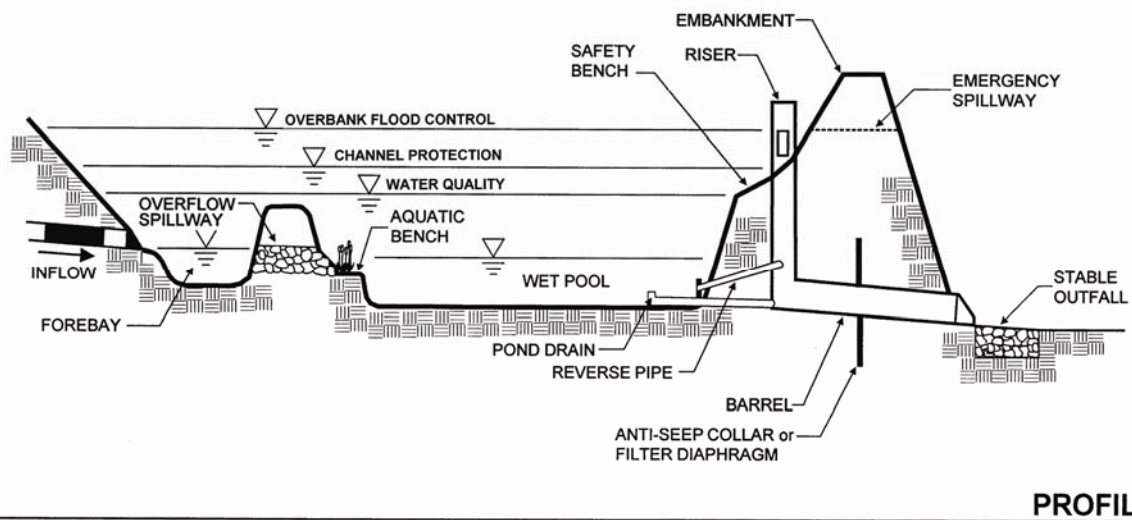
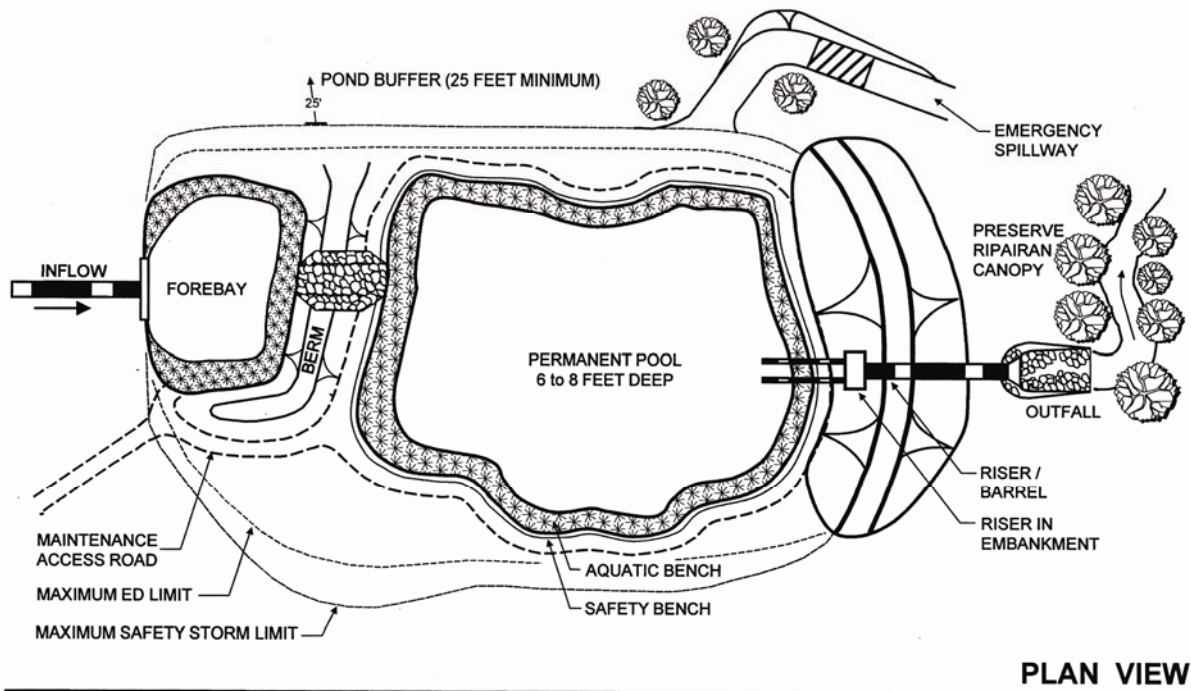

Figure 3.3 Wet Extended Detention Pond (P-3)

### 3.2.4.1a *Feasibility*

#### Required Elements

- Designs P-2 and P-3 shall have a minimum contributing drainage area of 25 acres. A 10-acre drainage area is required for design P-1.
- Stormwater ponds shall not be located within jurisdictional waters, including wetlands.
- Evaluate the site to determine the Hazard Class<sup>1</sup> and to determine what design elements are required to ensure dam safety.

#### Design Guidance

- Avoid location of pond designs within the stream channel, to prevent habitat degradation caused by these structures.

### 3.2.4.1b *Conveyance*

#### **Inlet Protection**

#### Required Elements

- A forebay shall be provided at each inlet, unless the inlet provides less than 10% of the total design storm inflow to the pond.

#### Design Guidance

- Inlet areas should be stabilized to ensure that non-erosive conditions exist for at least the 1-year frequency storm event.
- Partially submerged (i.e., ½ full) inlet pipes are acceptable and can limit erosive conditions.

#### **Adequate Outfall Protection**

#### Required Elements

- The channel immediately below a pond outfall shall be modified to prevent erosion and conform to natural dimensions in the shortest possible distance, typically by use of appropriately sized riprap placed over filter cloth.
- A stilling basin or outlet protection shall be used to reduce flow velocities from the principal spillway to non-erosive velocities (3.5 to 5.0 fps).

#### Design Guidance

- Outfalls should be constructed such that they do not increase erosion or have undue influence on the downstream geomorphology of the stream.

---

<sup>1</sup> Hazard Class is a classification system that ranks the relative risk of a pond embankment should it fail. Risk is a function of pond storage volume, embankment height, and the presence of downstream properties. A tall embankment with a large volume of water impounded by an earthen dam immediately above an inhabited structure will likely be a High Hazard Facility and subject to more stringent design criteria. Applicants must consult their Commonwealth or territorial agency to determine the exact criteria (see **Volume II, Chapter 6**).

- Flared pipe sections that discharge at or near the stream invert or into a step-pool arrangement should be used at the spillway outlet.
- If a pond daylights to a channel with dry weather flow (baseflow), care should be taken to minimize tree clearing along the downstream channel, and to reestablish a forested riparian zone in the shortest possible distance.

## **Pond Liners**

### Design Guidance

- When a pond is located in medium to coarse sands or within limestone formations, a liner may be needed to sustain a permanent pool of water. If geotechnical tests confirm the need for a liner, acceptable options include: (a) 6 to 12 inches of clay soil (minimum 30% passing the #200 sieve and a minimum permeability of  $1 \times 10^{-7}$  cm/sec), (b) a 30 mil poly-liner (c) bentonite, or (d) use of chemical additives.

#### *3.2.4.1c Pretreatment*

### **Sediment Forebay**

#### Required Elements

- A sediment forebay is important for maintenance and longevity of a stormwater treatment pond. Each pond shall have a sediment forebay or equivalent upstream pretreatment. The forebay shall consist of a separate cell, formed by an acceptable barrier. Typical examples include earthen berms, concrete weirs, and gabion baskets.
- The forebay shall be sized to contain 10% of the water quality volume ( $WQ_v$ ), and shall be four to six feet deep. The forebay storage volume counts toward the total  $WQ_v$  requirement.
- The forebay shall be designed with non-erosive outlet conditions.
- Direct access for appropriate maintenance equipment shall be provided to the forebay.

#### Design Guidance

- A fixed vertical sediment depth marker should be installed in the forebay to measure sediment deposition over time.
- The bottom of the forebay may be hardened (i.e., concrete, asphalt, grouted riprap) to make sediment removal easier.

#### *3.2.4.1d Treatment*

### **Minimum Water Quality Volume ( $WQ_v$ )**

#### Required Elements

- Provide water quality treatment storage to capture the computed  $WQ_v$  from the contributing drainage area through a combination of permanent pool, extended detention and marsh. Storage in permanent pool and extended detention is outlined in **Table 3.4**.

**Table 3.4 Water Quality Volume Distribution in Pond Designs**

Design Variation	%WQ <sub>v</sub>	
	Permanent Pool	Extended Detention
P-1	20% min.	80% max.
P-2	100%	0%
P-3	50% min.	50% max.

- If extended detention is provided in a pond, storage for the channel protection volume ( $C_{p_v}$ ) and the  $WQ_v$  shall be computed and routed separately (i.e., the  $WQ_v$  cannot be met simply by providing  $C_{p_v}$  storage for the one-year storm).

#### Design Guidance

- It is generally desirable to provide water quality treatment off-line<sup>1</sup> when topography, head and space permit.
- Water quality storage can be provided in multiple cells. Performance is enhanced when multiple treatment pathways are provided by using multiple cells, longer flowpaths, high surface area to volume ratios, complex microtopography, and/or redundant treatment methods (combinations of pool, ED, and marsh).

#### **Minimum Pond Geometry**

##### Required Elements

- The minimum length to width ratio for the pond is 1.5:1 (i.e., length relative to width).
- Provide a minimum Drainage Area: Surface Area Ratio of 75:1.

##### Design Guidance

- To the greatest extent possible, maintain a long flow path through the system, and design ponds with irregular shapes.

#### *3.2.4.1e Landscaping*

##### **Pond Benches**

##### Required Elements

- The perimeter of all deep pool areas (four feet or greater in depth) shall be surrounded by two benches:
  1. Except when pond side slopes are 4:1 (h:v) or flatter, provide a safety bench that generally extends 15 ft outward (a 10ft minimum bench is allowable on sites with extreme space limitations at the discretion of the reviewing authority) from the normal

<sup>1</sup> Off-line stormwater management systems are designed to manage a storm event by diverting a percentage of stormwater events from a stream or storm drainage system. See **Volume II, Figure 9.5** for a schematic comparing an off-line and on-line practice.

water edge to the toe of the pond side slope. The maximum slope of the safety bench shall be 6%; and

2. Incorporate an aquatic bench that generally extends up to 15 feet inward from the normal shoreline, has an irregular configuration, and a maximum depth of 18 inches below the normal pool water surface elevation.

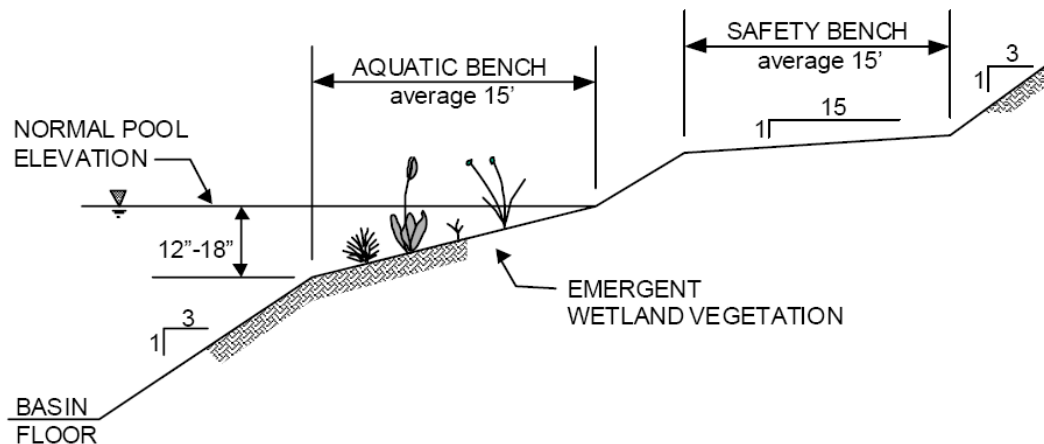

**Figure 3.4. Typical Stormwater Pond Geometry Criteria**  
*From the Georgia Stormwater Management Manual (ARC, 2001)*

## Landscaping Plan

### Required Elements

- A landscaping plan for a stormwater pond and its buffer shall be prepared to indicate how aquatic and terrestrial areas will be stabilized and established with vegetation.

### Design Guidance

- Wherever possible, wetland plants should be encouraged in a pond design, either along the aquatic bench (fringe wetlands), the safety bench and side slopes or within shallow areas of the pool itself.
- The best elevations for establishing wetland plants, either through transplantation or volunteer colonization, are within six inches (plus or minus) of the normal pool.
- The soils of a pond buffer are often severely compacted during the construction process to ensure stability. The density of these compacted soils is so great that it effectively prevents root penetration, and therefore, may lead to premature mortality or loss of vigor. Consequently, it is advisable to excavate large and deep holes around the proposed planting sites, and backfill these with uncompacted topsoil.
- As a rule of thumb, planting holes should be three times deeper and wider than the diameter of the rootball (of balled and burlap stock), and five times deeper and wider for container grown stock. This practice should enable the stock to develop unconfined root systems. Avoid species that require full shade or are prone to wind damage. Extra mulching around the base of the tree or shrub is strongly recommended as a means of conserving moisture and suppressing weeds.



## Pond Buffers and Setbacks

### Required Elements

- A pond buffer shall be provided that extends 25 feet outward from the maximum water surface elevation of the pond. The pond buffer shall be contiguous with other buffer areas that are required by other regulations. An additional setback may be provided to permanent structures.
- Woody vegetation may not be planted or allowed to grow on an earthen dam embankment, within 15 feet of the toe of the embankment or 25 feet from the principal spillway outlet structure.

### Design Guidance

- Existing trees should be preserved in the buffer area during construction. It is desirable to locate forest conservation areas adjacent to ponds. To help encourage reforestation, the buffer can be planted with trees, shrubs and native ground covers.
- Annual mowing of the pond buffer is only required along maintenance rights-of-way and the embankment. The remaining buffer can be managed as rangeland (mowing every other year) or forest.

#### *3.2.4.If Maintenance*

### Required Elements

- Maintenance responsibility for a pond and its buffer shall be vested with a responsible authority by means of a legally binding and enforceable maintenance agreement that is executed as a condition of plan approval.
- The principal spillway shall be equipped with a removable trash rack, and generally accessible from dry land.
- A maintenance and operation plan must specify that sediment removal in the forebay shall occur every 5 to 6 years or after 50% of total forebay capacity has been lost, whichever is greater.

### Design Guidance

- Sediments excavated from stormwater ponds that do not receive runoff from designated hotspots are generally not considered toxic or hazardous material, and can be safely disposed by either land application or land filling. Sediment testing may be required prior to sediment disposal when a hotspot land use is present (see **Section 2.1.1.1** for a list of potential hotspots).
- Sediment removed from stormwater ponds should be disposed of according to an approved comprehensive operation and maintenance plan.

More detailed maintenance guidance and pond operation and maintenance checklists are provided in **Volume II-Chapter 7**.

## **Maintenance Access**

### Required Elements

- A maintenance right of way or easement shall extend to a pond from a public or private road.

### Design Guidance

- Maintenance access should be at least 12 feet wide, have a maximum slope of no more than 15%, and be appropriately stabilized to withstand maintenance equipment and vehicles.
- The maintenance access should extend to the forebay, safety bench, outlet control structure, and outlet and be designed to allow vehicles to turn around.

## **Non-clogging Low-flow Orifice**

### Required Elements

- A low-flow orifice shall be provided, with the size for the orifice sufficient to ensure that no clogging shall occur.

### Design Guidance

- The low-flow orifice should be adequately protected from clogging by either an acceptable external trash rack (recommended minimum orifice of 3 in) or by internal orifice protection that may allow for smaller diameters (recommended minimum orifice of 1 in).
- The preferred method is a submerged reverse-slope pipe that extends downward from the outlet control structure to an inflow point one foot below the normal pool elevation.
- Alternative methods are to employ a broad-crested rectangular, V-notch, or proportional weir, protected by a half-round pipe or “hood” that extends at least 12 inches below the normal pool.
- The use of horizontally extended perforated pipe protected by geotextile fabric and limestone aggregate is not recommended. Vertical pipes may be used as an alternative if a permanent pool is present.
- See **Volume II, Section 9.2** for example details for low-flow orifice protection devices.

## **Outlet Control Structure in Embankment**

### Required Elements

- The outlet control structure shall be located within the embankment for maintenance access, safety and aesthetics.

### Design Guidance

- Access to the outlet control structure should be provided by lockable manhole covers, and manhole steps within easy reach of valves and other controls. The principal spillway opening should be "fenced" with pipe or rebar at 8-inch intervals (for safety purposes).

### **Pond Drain**

#### Required Elements

- Except where local slopes (e.g., coastal areas) prohibit this design, each pond shall have a drain pipe that can completely or partially drain the pond. The drain pipe shall have an elbow or protected intake within the pond to prevent sediment deposition, and a diameter capable of draining the permanent pool within 24 hours.

### **Safety Features**

#### Required Elements

- Side slopes to the pond shall not exceed 3:1 (h:v), and shall terminate on a safety bench.
- The principal spillway opening shall not permit access by small children, and endwalls above pipe outfalls greater than 48 inches in diameter shall be fenced to prevent a hazard.
- "Token" or emergency spillways (those placed above the water elevation of the largest managed storm) are required and must be a minimum 8 ft wide, 1 ft deep, with 2:1 side slopes. See **Volume II, Section 6.1** for more details on required spillways.

### Design Guidance

- Both the safety bench and the aquatic bench may be landscaped to prevent access to the pool.
- Warning signs prohibiting swimming may be posted.
- Pond fencing is generally not encouraged, but may be required by some owners and/or agencies. A preferred method is to manage the contours of the pond to eliminate dropoffs or other safety hazards.

**<This page left blank intentionally>**

**Stormwater Ponds**



**Description:** Constructed stormwater retention basin that has a permanent pool (or micropool). Runoff from each rain event is detained and treated in the pool through settling and biological uptake mechanisms.

Design Options:  
Micropool Extended Detention (P-1), Wet Pond (P-2), and Wet Extended and Detention (P-3)

**KEY CONSIDERATIONS**

**FEASIBILITY**

- Contributing drainage area greater than 10 acres for P-1, 25 acres for P-2 to P-3.
- Follow **Volume II, Chapter 6** Guidelines for Design of Embankments
- Do not locate ponds in jurisdictional wetlands

**CONVEYANCE**

- Forebay at each inlet, unless the inlet contributes less than 10% of the total inflow, 4 ft to 6ft deep.
- Stabilize the channel below the pond to prevent erosion.
- Stilling basin at the outlet to reduce velocities.

**PRETREATMENT**

- Forebay volume at least 10% of the  $WQ_v$
- Forebay shall be designed with non-erosive outlet conditions
- Provide direct access for maintenance equipment

**TREATMENT**

- Provide the water quality volume in a combination of permanent pool and extended detention (**Table 3.4** provides limitations on storage breakdown)
- Minimum length to width ratio of 1.5:1
- Minimum drainage area to surface area ratio of 75:1

**LANDSCAPING**

- Provide a minimum 10ft and preferably 15ft safety bench extending from the high water mark, with a maximum slope of 6%.
- Provide an aquatic bench extending 15 ft outward from the shoreline, and a maximum depth of 18in below normal water elevation.
- Develop a landscaping plan.
- Provide a 25ft pond buffer.

**STORMWATER MANAGEMENT SUITABILITY**

- Water Quality
- Recharge
- Channel Protection
- Overbank Flood Control

**Accepts Hotspot Runoff:** *Yes*  
(2 feet of separation distance required to water table)

**FEASIBILITY CONSIDERATIONS**

- L Capital Cost
- L Maintenance Burden

**Key:** L=Low M=Moderate H=High

**Residential Subdivision Use:** *Yes*  
**High Density/Ultra-Urban:** *No*

**Soils:** *Highly permeable soils/karst geology may require pond liner*

*Clay soils may have embankment compaction constraints*

**Other Considerations:**

- *Outlet clogging*
- *Safety bench*

- No woody vegetation on dams, within 15 ft of the toe of an embankment, or 25 ft from the principal spillway.

**MAINTENANCE REQUIREMENTS**

- Legally binding maintenance agreement
- O/M plan that specifies sediment removal from forebay every five to six years or when 50% full.
- Provide a maintenance easement or right-of-way.
- Removable trash rack on the principal spillway.
- Non-clogging low flow orifice
- Outlet control structure in the embankment.
- Pond drain required, capable of drawing down the pond in 24 hours.
- Side Slopes equal to or flatter than 3:1, and terminating in a safety bench.
- Principal spillway shall not permit access by small children, and endwalls above pipes greater than 48-in diameter shall be fenced.

**POLLUTANT REMOVAL**

- G** **Phosphorus**
- G** **Nitrogen**
- G** **Metals - Cadmium, Copper, Lead, and Zinc removal**
- G** **Pathogens Coliform, E.Coli, Streptococci removal**

**Key: G=Good F=Fair P=Poor**

### 3.2.4.2 Stormwater Wetlands

Stormwater wetlands are practices that create shallow marsh areas to treat urban stormwater and often incorporate small permanent pools and/or extended detention storage to achieve the full WQv. Design variants include:

- W-1        Shallow Wetland                    **(Figure 3.5)**
- W-2        ED Shallow Wetland                    **(Figure 3.6)**
- W-3        Pocket Wetland/Pond                    **(Figure 3.7)**

All wetland design variants can be used to provide Channel Protection volume as well as Overbank Flood attenuation. In these designs, the permanent pool is stored in a depression excavated into the ground surface. Wetland plants are planted at the wetland bottom, particularly in the shallow regions.

The term "pocket" refers to a wetland or pond that has such a small contributing drainage area that little or no baseflow is available to sustain water elevations during dry weather. Instead, water elevations are heavily influenced and, in some cases, maintained by groundwater.

#### NOTES:

All of the pond criteria presented in stormwater ponds (**Chapter 3.2.4.1**) also apply to the design of stormwater wetlands. Additional criteria that govern the geometry and establishment of created wetlands are presented in this section.

Any practice that creates an embankment is required to follow the guidance presented in the *Embankment Standards and Specifications* (**Volume II, Chapter 6**) and may require a permit from the Commonwealth or Territory.

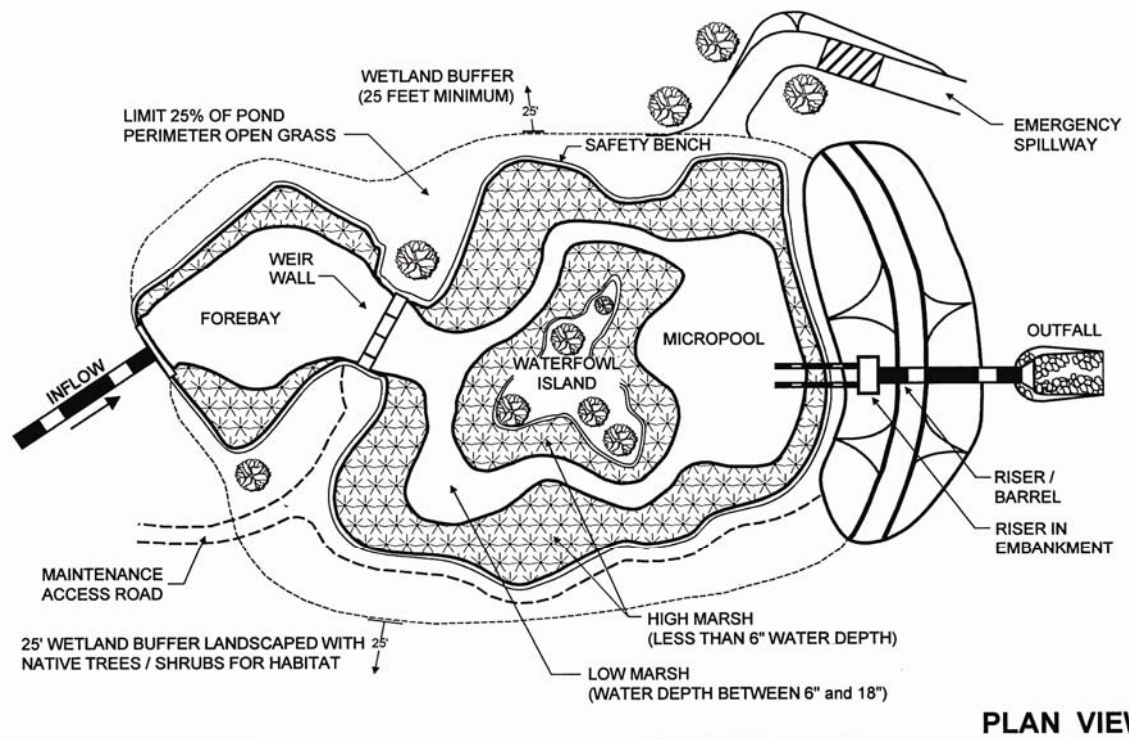

**PLAN VIEW**

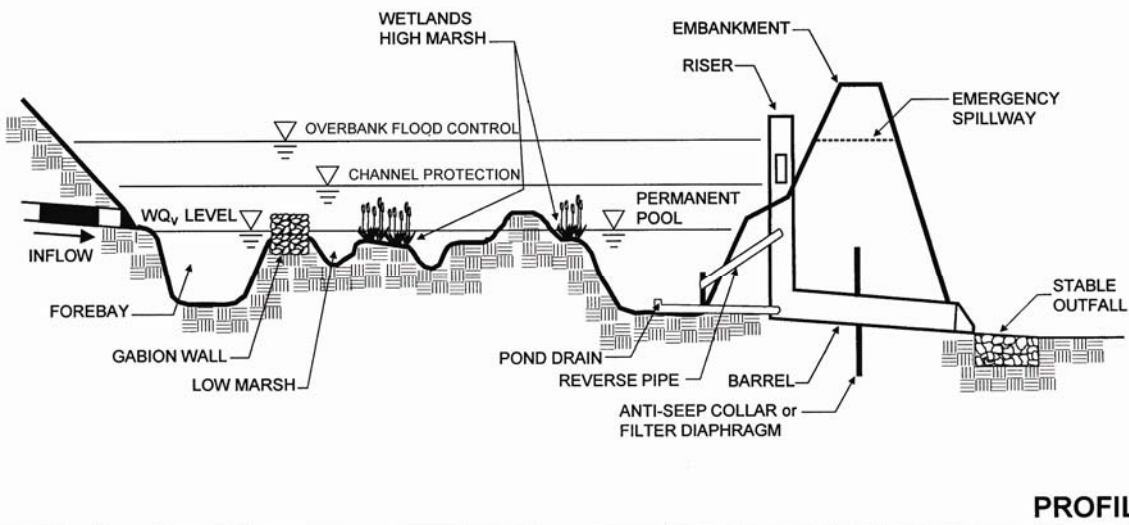

**PROFILE**

**Figure 3.5 Shallow Marsh (W-1)**



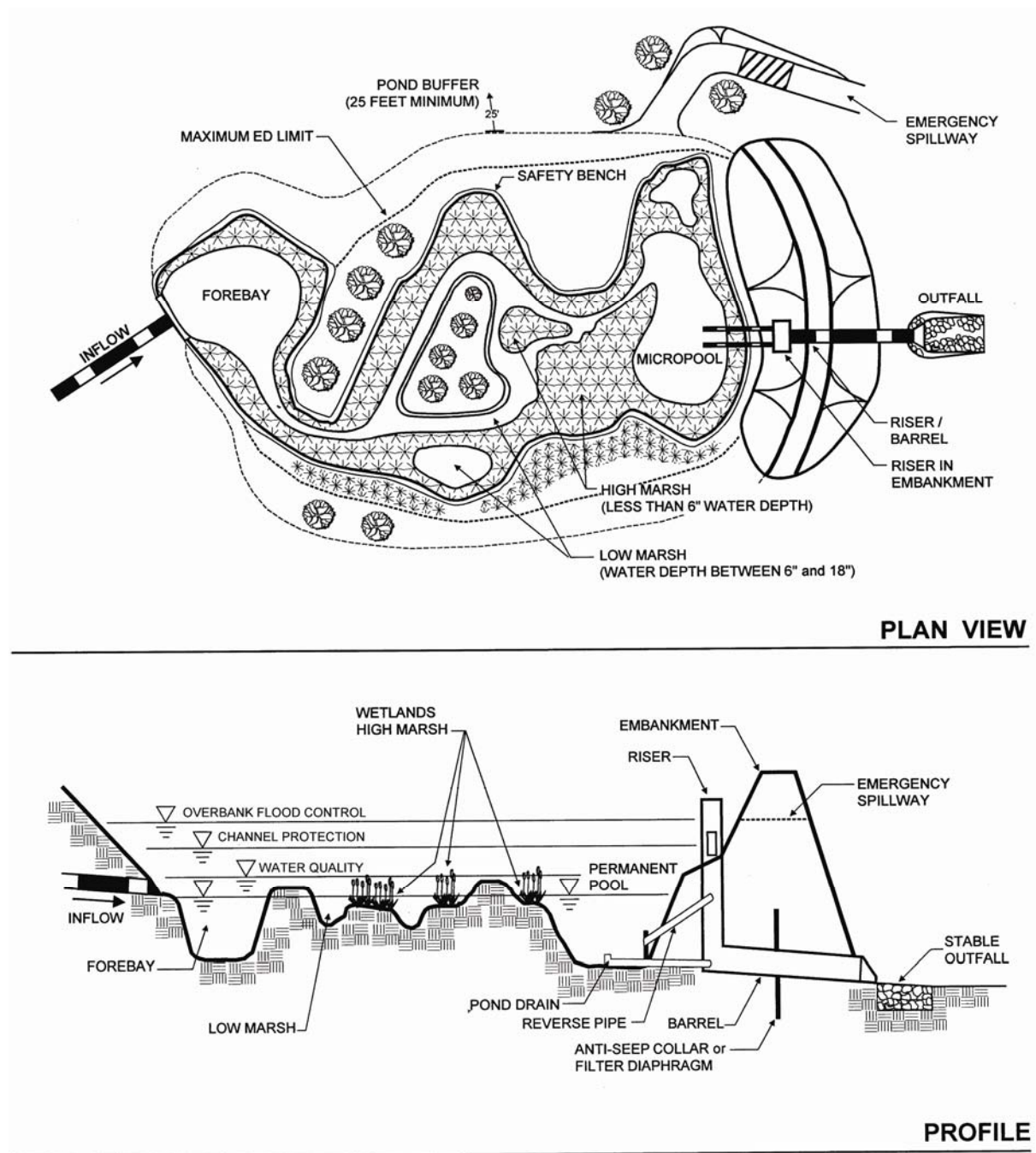

**Figure 3.6 Extended Detention Shallow Wetland (W-2)**

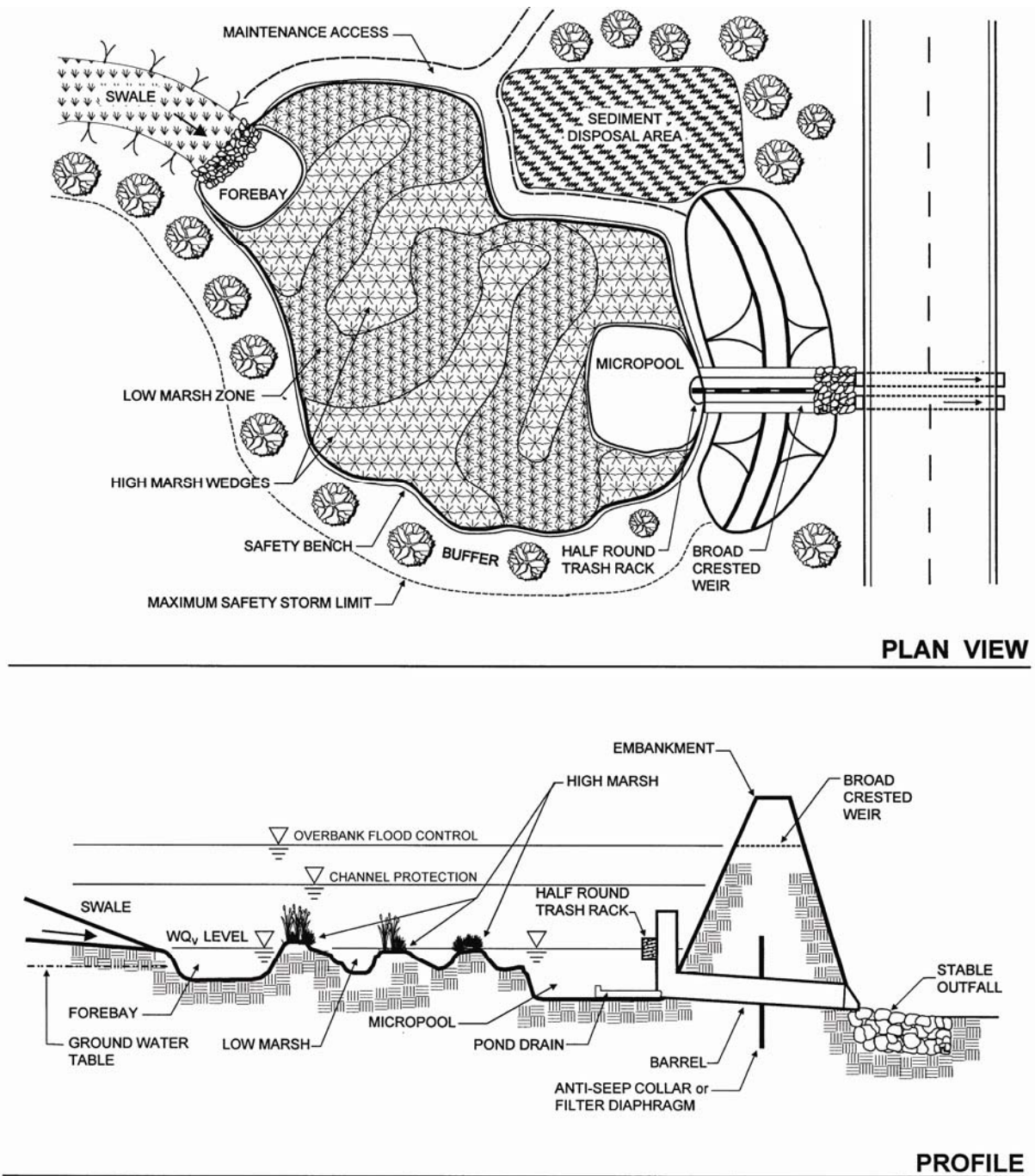

Figure 3.7 Pocket Wetland (W-3)

### 3.2.4.2a *Feasibility*

#### Design Guidance

- *Stormwater wetlands should not be located within existing jurisdictional wetlands.* In some isolated cases, a permit may be granted to convert an existing degraded wetland in the context of local watershed restoration efforts.

### 3.2.4.2b *Conveyance*

#### Required Elements

- Flowpaths from the inflow points to the outflow points of stormwater wetlands shall be maximized.
- A minimum flowpath of 2:1 (length to relative width) shall be provided across the stormwater wetland. This path may be achieved by constructing internal berms (e.g., high marsh wedges or rock filter cells).

#### Design Guidance

- Microtopography (complex contours along the bottom of the wetland system, providing greater depth variation) is encouraged to enhance wetland diversity.

### 3.2.4.2c *Pretreatment*

#### Required Elements

- A forebay shall be located at the inlet, and a four to six foot deep micropool that stores approximately 10% of the  $WQ_v$  shall be located at the outlet to protect the low-flow outlet structure from clogging and prevent sediment resuspension.

### 3.2.4.2d *Treatment*

#### Required Elements

- The surface area of the entire stormwater wetland shall be at least one percent of the contributing drainage area (1.5% for shallow marsh design).
- At least 25% of the  $WQ_v$  of a stormwater wetland shall be in deepwater zones with a depth greater than four feet.
- A minimum of 35% of the total surface of area of stormwater wetlands can have a depth of six inches or less, and at least 65% of their total surface area shall be shallower than 18 inches.

#### Design Guidance

- The bed of stormwater wetlands should be graded to create maximum internal flow path and microtopography.
- To promote greater nitrogen removal, rock beds may be used as a medium for growth of wetland plants. The rock should be one to three inches in diameter, placed up to the normal pool elevation, and open to flow-through from either direction.

### 3.2.4.2e *Landscaping*

#### Required Elements

- A landscaping plan shall be provided that indicates the methods used to establish and maintain wetland coverage. Minimum elements of a plan include: delineation of pondscaping zones, selection of corresponding plant species, planting plan, sequence for preparing wetland bed (including soil amendments, if needed), and sources of plant material.
- For stormwater wetlands, a wetland plant buffer must extend 25 ft outward from the maximum water surface elevation, with an additional 15-ft setback to structures.
- Donor soils for wetland mulch shall not be removed from natural wetlands.

#### Design Guidance

- Structures such as fascines, coconut rolls, or carefully designed stone weirs can be used to create shallow marsh cells in high-energy flow areas of the stormwater wetland.
- The landscaping plan should provide elements that promote greater wildlife and waterfowl use within the wetland and buffers.
- Follow wetland plant establishment guidelines (See **Volume II-Chapter 5**).

### 3.2.4.2f *Maintenance*

#### Required Elements

- An operation and maintenance plan shall specify that if a minimum coverage of 50% is not achieved in the planted wetland zones after the second growing season, a reinforcement planting is required.

**Stormwater Wetlands**



**Description:** Stormwater wetlands (a.k.a. constructed wetlands) are structural practices that incorporate wetland plants into the design to both store and treat runoff. As stormwater runoff flows through the wetland, pollutant removal is achieved through settling and biological uptake within the practice

Design Options:  
Shallow wetland (W-1), Extended Detention Wetland (W-2), and Pocket Wetland (W-3)

<u>KEY CONSIDERATIONS</u>	<u>STORMWATER MANAGEMENT SUITABILITY</u>
<p><b>MUST MEET ALL OF THE REQUIREMENTS OF STORMWATER PONDS.</b></p> <p><b>CONVEYANCE</b></p> <ul style="list-style-type: none"> <li>• Minimum flowpath of 2:1 (length to width)</li> <li>• Flowpath maximized</li> </ul> <p><b>PRETREATMENT</b></p> <ul style="list-style-type: none"> <li>• Micropool at outlet, capturing 10% of the WQ<sub>v</sub></li> </ul> <p><b>TREATMENT</b></p> <ul style="list-style-type: none"> <li>• Minimum surface area/ drainage area ratio of 100:1.</li> <li>• ED no greater than 50% of entire WQ<sub>v</sub></li> <li>• 25% of the WQ<sub>v</sub> in deepwater zones.</li> <li>• 35% of the total surface area in depths six inches or less, and 65% shallower than 18.”</li> </ul>	<ul style="list-style-type: none"> <li><input checked="" type="checkbox"/> Water Quality</li> <li><input type="checkbox"/> Recharge</li> <li><input checked="" type="checkbox"/> Channel Protection</li> <li><input checked="" type="checkbox"/> Overbank Flood Control</li> </ul> <p><b>Accepts Hotspot Runoff:</b> <i>Yes</i> <i>(2 feet of separation distance required to water table)</i></p> <p><u>IMPLEMENTATION CONSIDERATIONS</u></p> <ul style="list-style-type: none"> <li><input type="checkbox"/> Capital Cost</li> </ul> <p><b>Maintenance Burden:</b></p> <ul style="list-style-type: none"> <li><input type="checkbox"/> Shallow Wetland</li> <li><input type="checkbox"/> ED Shallow Wetland</li> <li><input type="checkbox"/> Pocket Wetland</li> </ul> <p><b>Residential Subdivision Use:</b> <i>Yes</i> <b>High-Density/Ultra-Urban:</b> <i>No</i></p> <p><b>Soils:</b> <i>Highly permeable soils/karst geology may require liner</i></p> <p><b>Key :</b> L=Low M=Moderate H=High</p>

<p><b>LANDSCAPING</b></p> <ul style="list-style-type: none"> <li>• Landscaping plan that indicates methods to establish and maintain wetland coverage. Minimum elements include: delineation of pondscaping zones, selection of species, planting plan, and sequence for planting bed preparation.</li> <li>• Wetland buffer 25 feet from maximum surface elevation, with 15-foot additional setback for structures.</li> <li>• Donor plant material must not be from natural wetlands</li> </ul> <p><b>MAINTENANCE REQUIREMENTS</b></p> <ul style="list-style-type: none"> <li>• O/M plan to specify reinforcement plantings after second season if 50% coverage not achieved</li> </ul>	<p><b><u>POLLUTANT REMOVAL</u></b></p> <p><b>G</b> Phosphorus</p> <p><b>G</b> Nitrogen</p> <p><b>F</b> Metals - Cadmium, Copper, Lead, and Zinc removal</p> <p><b>G</b> Pathogens - Coliform, Streptococci, E. coli removal</p> <p><b>Key: G=Good F=Fair P=Poor</b></p>
---	---

### 3.2.4.3 Stormwater Infiltration

Stormwater infiltration practices capture and temporarily store the  $WQ_v$  before allowing it to infiltrate into the soil over a two-day period. Design variants include:

- I-1 Infiltration Trench/Chamber **(Figure 3.8)**
- I-2 Infiltration Basin **(Figure 3.9)**

Treatment Suitability: Infiltration practices typically cannot provide channel protection ( $Cp_v$ ) and/or overbank flood control ( $Q_{p-25}$ ) storage, except on sites where the soil infiltration rate is greater than 5.0 in/hr. Extraordinary care should be taken to assure that long-term infiltration rates are achieved through the use of performance bonds, post construction inspection and long-term maintenance. Infiltration within limestone formations that have very high permeability rates may allow for infiltration of large volumes of stormwater. Applicants must provide treatment of 100% of the  $WQ_v$  prior to direct infiltration into limestone bedrock – infiltration practices can be used for treating the  $WQ_v$  only if located within the soil profile at least 3 feet above the bedrock. Roof runoff can be infiltrated directly, without treatment, and counted toward both  $Re_v$  and  $WQ_v$  requirements.

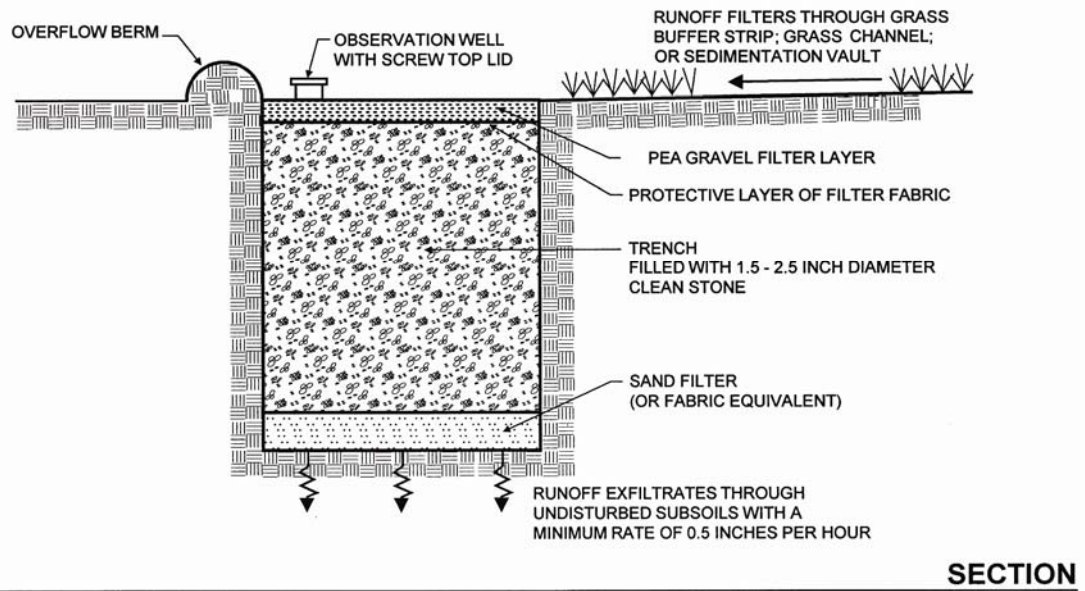
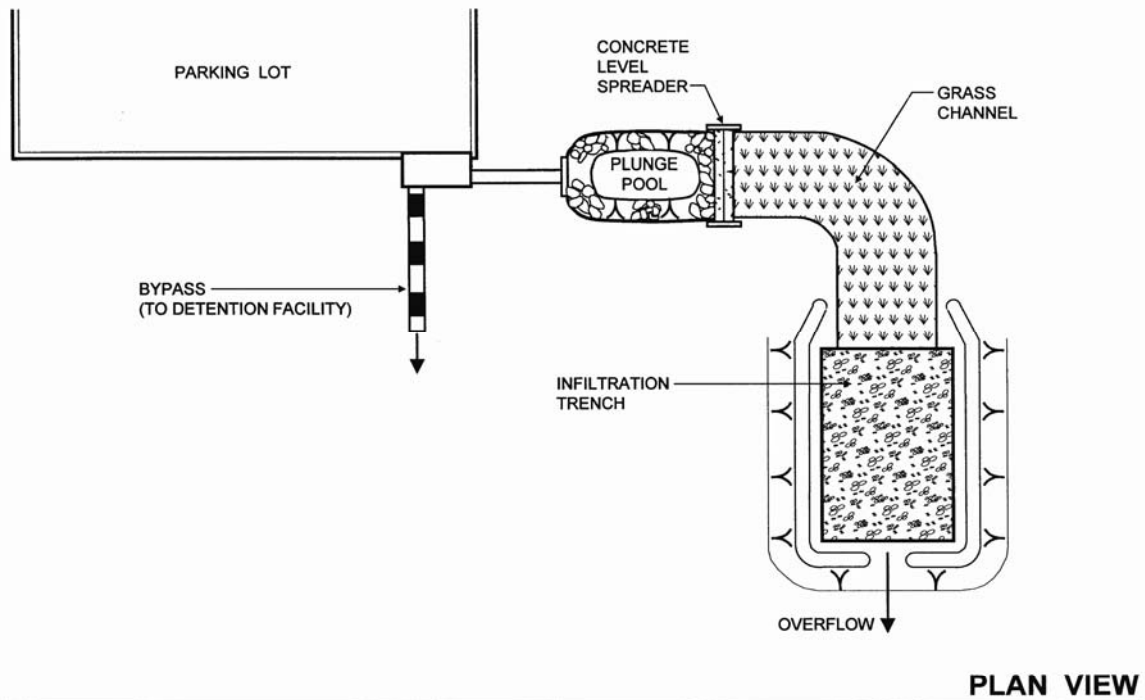
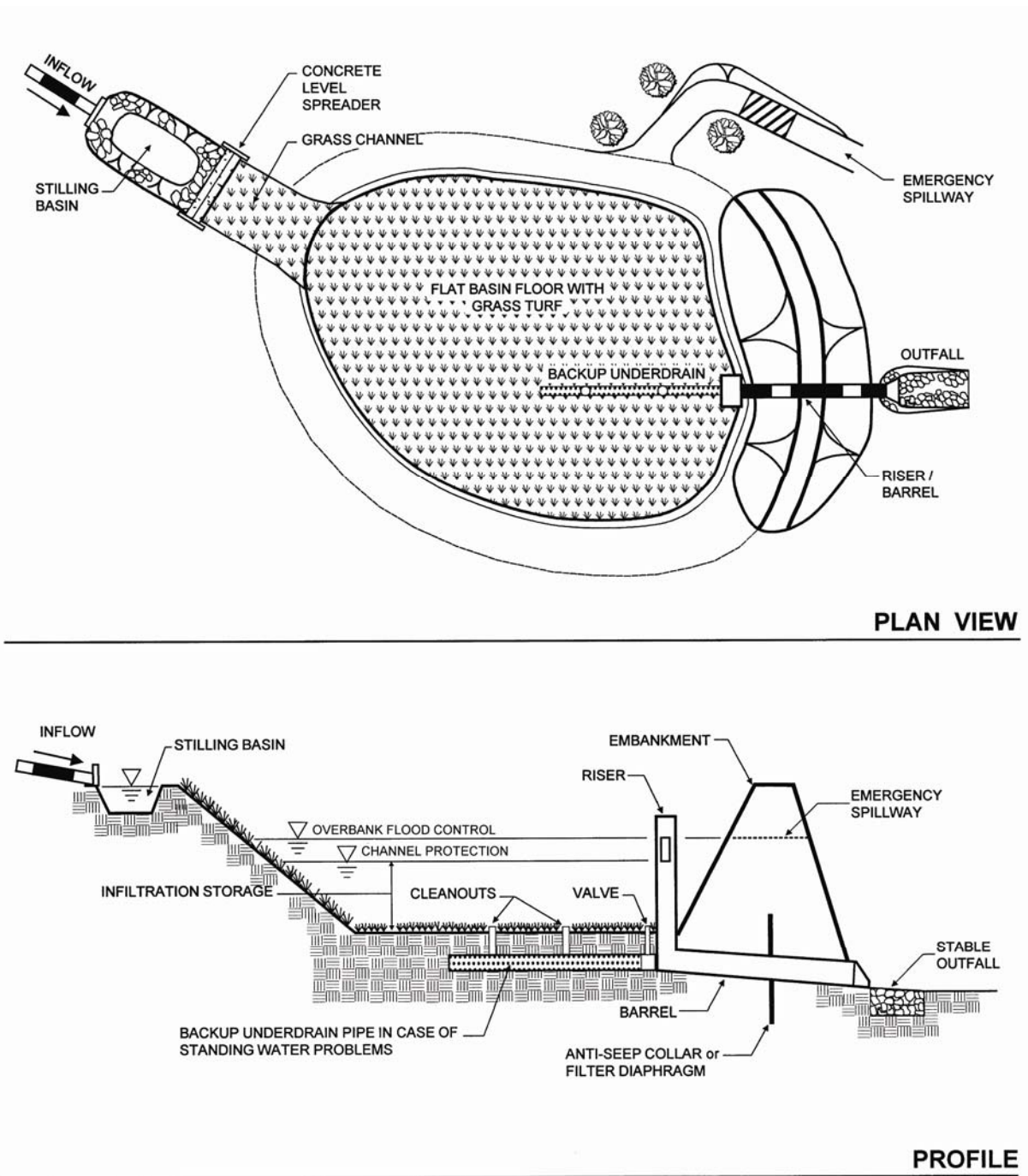

Figure 3.8 Infiltration Trench/Chamber (I-1)





**Figure 3.9 Infiltration Basin (I-2)**

### 3.2.4.3a *Feasibility*

#### Required Elements

- To be suitable for infiltration, underlying soils shall have an infiltration rate ( $f_c$ ) of at least 0.5 inches per hour, as initially determined from NRCS soil textural classification, and subsequently confirmed by field geotechnical tests (see **Volume II, Section 9.1** for testing guidance). The minimum geotechnical testing at the site of a proposed infiltration practice is one test hole per 5,000 ft<sup>2</sup>, with a minimum of two borings per infiltration facility (taken within the proposed limits of the facility).
- Soils shall also have a clay content of less than 20% and a silt/clay content of less than 40%.
- Infiltration practices cannot be located on areas with natural slopes greater than 15%, with the exception of infiltration facilities installed in limestone bedrock and used only for quantity control (not for  $WQ_v$  treatment); where design must be reviewed by a geotechnical engineer.
- Infiltration practices cannot be located in fill soils, except the top quarter of an infiltration trench.
- To protect groundwater from possible contamination, runoff from designated hotspot land uses or activities must not be directed to an infiltration facility. In cases where this goal is impossible (e.g., where the storm drain system leads to a large recharge facility designed for flood control), redundant pretreatment must be provided by applying two of the practices listed in **Table 3.3** in series, which are sized to collectively treat the entire  $WQ_v$  or  $Re_v$ , whichever is greater.
- The bottom of the infiltration facility shall be separated by at least three (3) feet vertically from the seasonally high water table or bedrock layer (when treating  $WQ_v$ ), as documented by on-site soil testing.
- Infiltration facilities shall be located at least 100 feet horizontally from any water supply well.
- Infiltration practices cannot be placed in locations that cause water problems (such as seepage which may cause slope failure) to downgrade properties. Infiltration trenches, chambers and basins shall be setback 25 feet down-gradient from building structures and on-site wastewater disposal systems (OSDS).

#### Design Guidance

- The maximum contributing area to infiltration basins, chambers, and trenches should generally be less than 5 acres. The infiltration basin can theoretically receive runoff from larger areas, provided that the soil is highly permeable (i.e., greater than 5.0 inches per hour).

### 3.2.4.3b *Conveyance*

#### Required Elements

- The overland flow path of surface runoff exceeding the capacity of the infiltration system shall be evaluated to preclude erosive concentrated flow during the overbank events. If computed flow velocities exiting the system over-bank exceed erosive velocities (3.5 to 5.0 fps), an overflow channel shall be provided to a stabilized watercourse.
- All infiltration systems shall be designed to fully de-water the entire  $WQ_v$  within 48 hours after the storm event.

- If runoff is delivered by a storm drain pipe or along the main conveyance system, the infiltration practice must be designed as an off-line practice, except when used as a regional flood control practice.

#### Design Guidance

- For infiltration basins, chambers, and trenches, adequate stormwater outfalls should be provided for the overflow associated with the 2-year design storm event (non-erosive velocities on the down-slope).

#### 3.2.4.3c *Pretreatment*

##### Required Elements

- For infiltration basins, chambers, and trenches, a minimum pretreatment volume of at least 25% of the  $WQ_v$  must be provided prior to entry to an infiltration facility, and can be provided in the form of a sedimentation basin, sump pit, grass channel, stilling basin or other similar sediment particle settling device.
- If the  $f_c$  for the underlying soils is greater than 2.0 inches per hour, a minimum pretreatment volume of at least 50% of the  $WQ_v$  must be provided.
- If the  $f_c$  for the underlying soils is greater than 5.0 inches per hour, 100% of the  $WQ_v$  shall be pre-treated prior to entry into an infiltration facility.
- Exit velocities from pretreatment chambers flowing over vegetated channels shall be non-erosive (3.5 to 5.0 fps) during the 2-year design storm.

#### **Pretreatment Techniques to Prevent Clogging**

Infiltration basins or trenches can have redundant methods to protect the long-term integrity of the infiltration rate. Three or more of the following techniques must be installed for infiltration basins or trenches:

- Grass channel (Maximum velocity of 1 fps for water quality flow. See **Section 3.2.4.6** for more design information)
- Grass filter strip (minimum 20 feet and only if sheet flow is established and maintained)
- Bottom sand layer
- Upper sand layer (6in minimum with filter fabric at the sand/limestone aggregate interface)
- Use of washed, rounded coral as aggregate (1/8in to 3/8in)
- Alternatively, a pre-treatment settling chamber may be provided and sized to capture the pretreatment volume. Use the method prescribed in **Section 3.2.4.4c** (i.e., the Camp-Hazen equation) to size the chamber.

#### Design Guidance

- The sides of infiltration trenches and dry wells should be lined with an acceptable filter fabric that prevents soil piping.
- In infiltration trench designs, incorporate filter fabric over washed limestone or sand above the coarse limestone aggregate treatment reservoir to serve as a filter layer.

3.2.4.3d *Treatment*Required Elements

- Infiltration practices shall be designed to exfiltrate the entire  $WQ_v$  through the floor of each practice (sides are not considered in sizing).
- The construction sequence and specifications for each infiltration practice shall be precisely followed. Experience has shown that the longevity of infiltration practices is strongly influenced by the care taken during construction.
- Design infiltration rates ( $f_c$ ) should be determined by using **Table 3.5**. These are conservative values that take into account future clogging as the practice is used over the years.

**Table 3.5. Design Infiltration Rates for Different Soil Texture Classes**

USDA Soil Texture	Infiltration Rate ( $f_c$ ) (in/hr)	Infiltration Rate ( $f_c$ ) (ft/min)
Sand	8.27	0.0115
Loamy Sand	2.41	0.0033
Sandy Loam	1.02	0.0014
Loam	0.52	0.0007
Silt Loam	0.27	0.0004
Sandy Clay Loam	0.17	0.0002
Clay Loam	0.09	0.0001
Silty Clay Loam	0.06	0.0001
Sandy Clay	0.05	0.0001
Silty Clay	0.04	0.0001
Clay	0.02	0.0000

Source: Standards and Specifications for Infiltration Practices (MDE, 1983)

- Calculate the surface area of infiltration trenches as:

$$A_p = V_w / (nd_t + f_c T/12)$$

Where:

- $A_p$  = surface area at the bottom of the trench ( $ft^2$ )
- $V_w$  = design volume (e.g.,  $WQ_v$ ) ( $ft^3$ )
- $n$  = porosity of limestone aggregate fill (assume 0.4)
- $d_t$  = trench depth (separated at least three feet from seasonally high groundwater) (ft)
- $f_c$  = infiltration rate (in/hr)
- $T$  = time to fill trench (hours) (assumed to be 2 hours for design purposes)

- Calculate the design volume of infiltration chambers as:

$$V_w = L * [(w * d * n) - (\# * A_c * n) + (\# * A_c) + (w * f_c * T / 12)]$$

Where:

$V_w$	=	design volume (e.g., $WQ_v$ ) ( $ft^3$ )
$L$	=	length of infiltration facility (ft)
$w$	=	width of infiltration facility (ft)
$h$	=	depth of infiltration facility (ft)
$\#$	=	number of rows of chambers
$A_c$	=	cross-sectional area of chamber (see manufacturer's specifications)
$n$	=	porosity (assume 0.4)
$f_c$	=	infiltration rate (in/hr)
$T$	=	time to fill chambers (hours) (assumed to be 2 hours for design purposes)

- One way to calculate the surface area of trapezoidal infiltration basins is to use the following equation:

$$A_b = (2V_w - A_t d_b) / (d_b - P/6 + f_c T / 6)$$

Where:

$A_b$	=	surface area at the bottom of the basin ( $ft^2$ )
$V_w$	=	design volume (e.g., $WQ_v$ ) ( $ft^3$ )
$A_t$	=	area at the top of the basin ( $ft^2$ )
$d_b$	=	depth of the basin (ft)
$P$	=	design rainfall depth (inches)
$f_c$	=	infiltration rate (in/hr)
$T$	=	time to fill basin (hours) (assumed to be 2 hrs for design purposes)

### Design Guidance

- Infiltration practices are best used in conjunction with other practices, and often downstream detention is still needed to meet the  $C_{p_v}$  and  $Q_{p-25}$  sizing criteria.
- A porosity value ( $V_v/V_t$ ) of 0.4 can be used to design stone reservoirs for infiltration practices.

The bottom of the stone reservoir should be completely flat so that infiltrated runoff will be able to infiltrate through the entire surface.

#### *3.2.4.3e Landscaping*

##### Required Elements

- Upstream construction shall be completed and stabilized before connection to a downstream infiltration facility. A dense and vigorous vegetative cover shall be established over the contributing pervious drainage areas before runoff can be accepted into the facility.

### Design Guidance

- Mow upland and adjacent areas, and seed bare areas.

#### *3.2.4.3f Maintenance*

##### Required Elements

- Infiltration practices shall never serve as a sediment control device during site construction phase. In addition, the Erosion and Sediment Control plan for the site shall clearly indicate how sediment will be prevented from entering the site of an infiltration facility. Normally, using diversion berms around the perimeter of the infiltration practice, along with immediate vegetative stabilization and/or mulching does this.
- An observation well shall be installed in every infiltration trench or chamber, consisting of an anchored 4 to 6-inch diameter perforated PVC pipe with a lockable cap installed flush with the ground surface.
- Preferably, direct access should be provided to infiltration practices for maintenance and rehabilitation. For stone reservoirs (trenches) or perforated pipes (chambers), which are used to temporarily store runoff prior to infiltration, the practice should ideally not be completely covered by an impermeable surface unless design constraints exist.

### Design Guidance

- OSHA trench safety standards should be consulted if the infiltration trench will be excavated more than five feet.
- Infiltration designs should include dewatering methods in the event of failure. Dewatering can be accomplished with underdrain pipe systems that accommodate drawdown.

**Infiltration Practices**



**Description:** Excavated trench or basin filled with stone aggregate (or other storage method) used to capture and allow infiltration of stormwater runoff into the surrounding soils from the bottom of the basin or trench.

Design Options:  
Infiltration Chambers/Trenches (I-1), Shallow Infiltration Basin (I-2)

**KEY CONSIDERATIONS**  
**FEASIBILITY**

- Minimum soil infiltration rate of 0.5 inches per hour.
- Soils less than 20% clay, and 40% silt/clay.
- Natural slope less than 15%.
- Cannot accept hotpot runoff, except under the conditions outlined in **Section 2.1.1.1**.
- Separation from groundwater table of at least three (3) feet.

**CONVEYANCE**

- Flows exiting the practice through vegetation must be non-erosive (3.5 to 5.0 fps).
- Maximum dewatering time of 48 hours.
- Design off-line if stormwater is conveyed to the practice by a storm drain pipe.

**PRETREATMENT**

- Pretreatment of 25% of the WQv at all sites.
- 50% pretreatment if  $f_c > 2.0$  inches/hour.
- 100% pretreatment in areas with  $f_c > 5.0$  inches/hour.
- Exit velocities from pretreatment through vegetation must be non-erosive for the 2-year storm.

**TREATMENT**

- Water quality volume designed to exfiltrate through the floor of the practice.
- Construction sequence to maximize practice life.

**STORMWATER**  
**MANAGEMENT SUITABILITY**

- Recharge**
- Water Quality**
- Channel Protection\***
- Overbank Flood Control\***

\* Infiltration basin only

**Accepts Hotspot Runoff:** *No*

**IMPLEMENTATION**  
**CONSIDERATIONS**

- H** **Capital Cost**
- H** **Maintenance Burden**

**Residential/Subdivision Use:** *Yes*  
**High Density/Ultra-Urban:** *Yes*

**Drainage Area:** *10 acres max.*

**Soils:** *Pervious soils required (0.5 in/hr or greater)*

**Other Considerations:**

- *Ideally not placed under pavement or concrete for easy maintenance*

**Key: L=Low M=Moderate H=High**

<p><b>LANDSCAPING</b></p> <ul style="list-style-type: none"> <li>Upstream area shall be completely stabilized before flow is directed to the practice.</li> </ul> <p><b>MAINTENANCE REQUIREMENTS</b></p> <ul style="list-style-type: none"> <li>Never serves as a sediment control device.</li> <li>Observation well shall be installed in every trench, (4-6" PVC pipe, with a lockable cap).</li> <li>Provide direct maintenance access.</li> </ul>	<p><b><u>POLLUTANT REMOVAL</u></b></p> <p><b>G</b> <b>Phosphorus</b></p> <p><b>G</b> <b>Nitrogen</b></p> <p><b>G</b> <b>Metals</b> - Cadmium, Copper, Lead, and Zinc removal</p> <p><b>G</b> <b>Pathogens</b> - Coliform, <i>Streptococci</i>, <i>E. coli</i> removal</p> <p><b>Key: G=Good F=Fair P=Poor</b></p>
---	---



### 3.2.4.4 Stormwater Filtering Systems

Stormwater filtering systems capture and temporarily store the  $WQ_v$  and pass it through a filter bed of sand, organic matter, or soil. Filtered runoff may be collected and returned to the conveyance system, or allowed to partially exfiltrate into the soil. Design variants include:

F-1	Sand Filter	(Figure 3.10)
F-2	Organic Filter	(Figure 3.11)
F-3	Bioretention	(Figure 3.12)

Treatment Suitability: Filtering systems should not be designed to provide channel protection ( $Cp_v$ ) or overbank flood control ( $Q_{p-25}$ ) except under extremely unusual conditions. Filtering practices shall generally be combined with a separate facility to provide those controls.

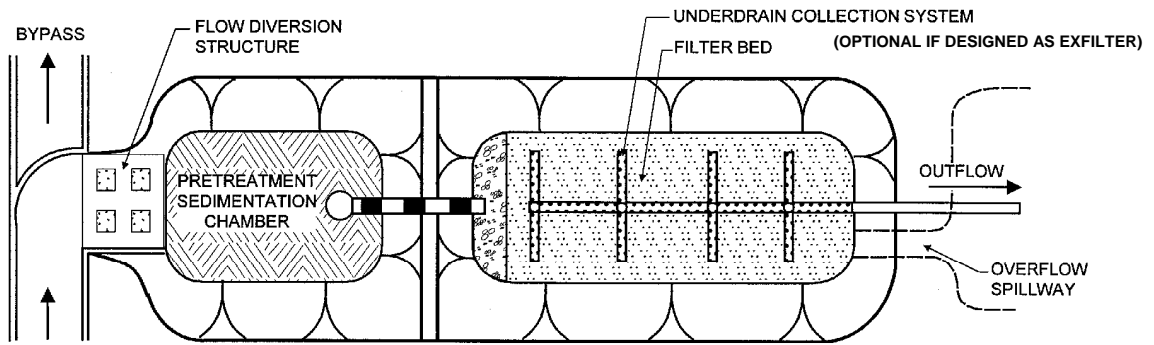

**PLAN VIEW**

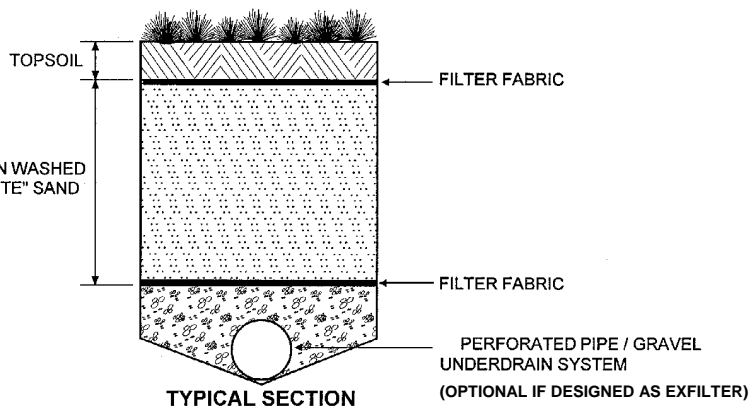
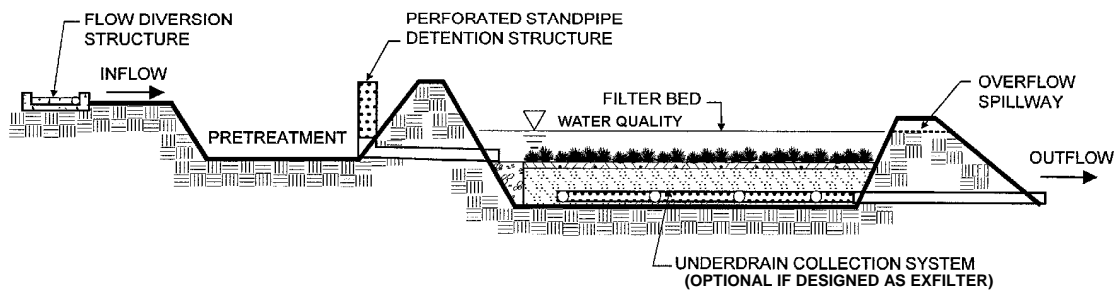

**TYPICAL SECTION**

**PROFILE**

**Figure 3.10 Sand Filter (F-1)**

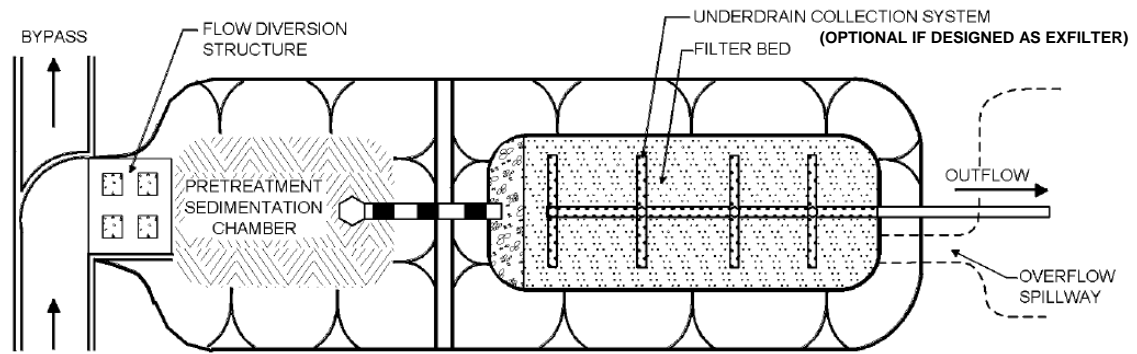

**PLAN VIEW**

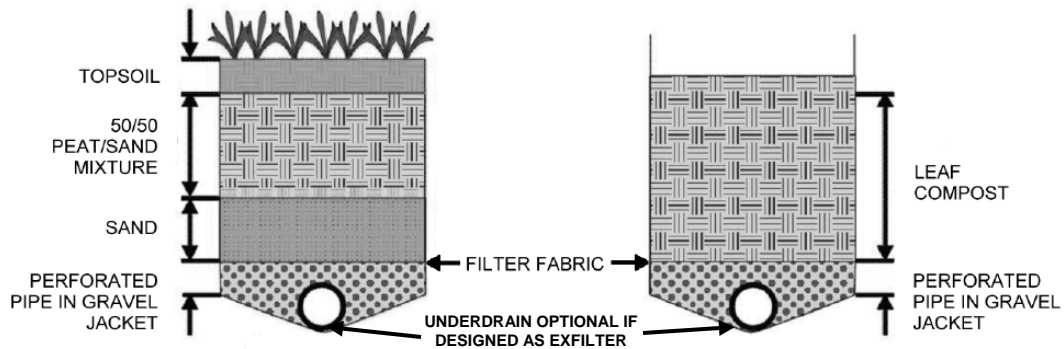
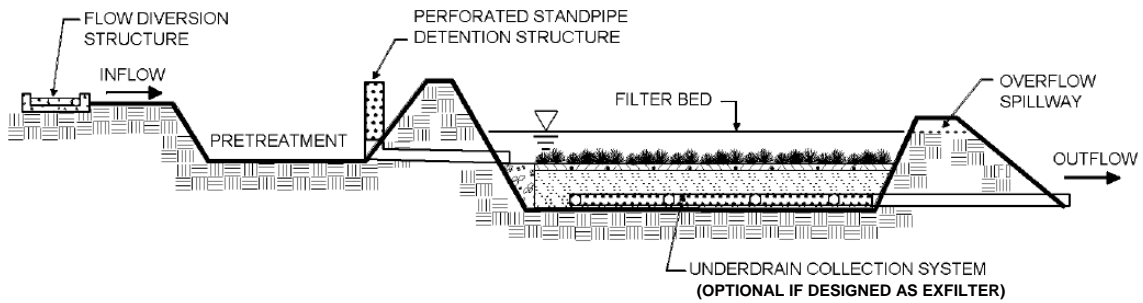

**TYPICAL SECTIONS**

**PROFILE**

**Figure 3.11 Organic Filter (F-2)**

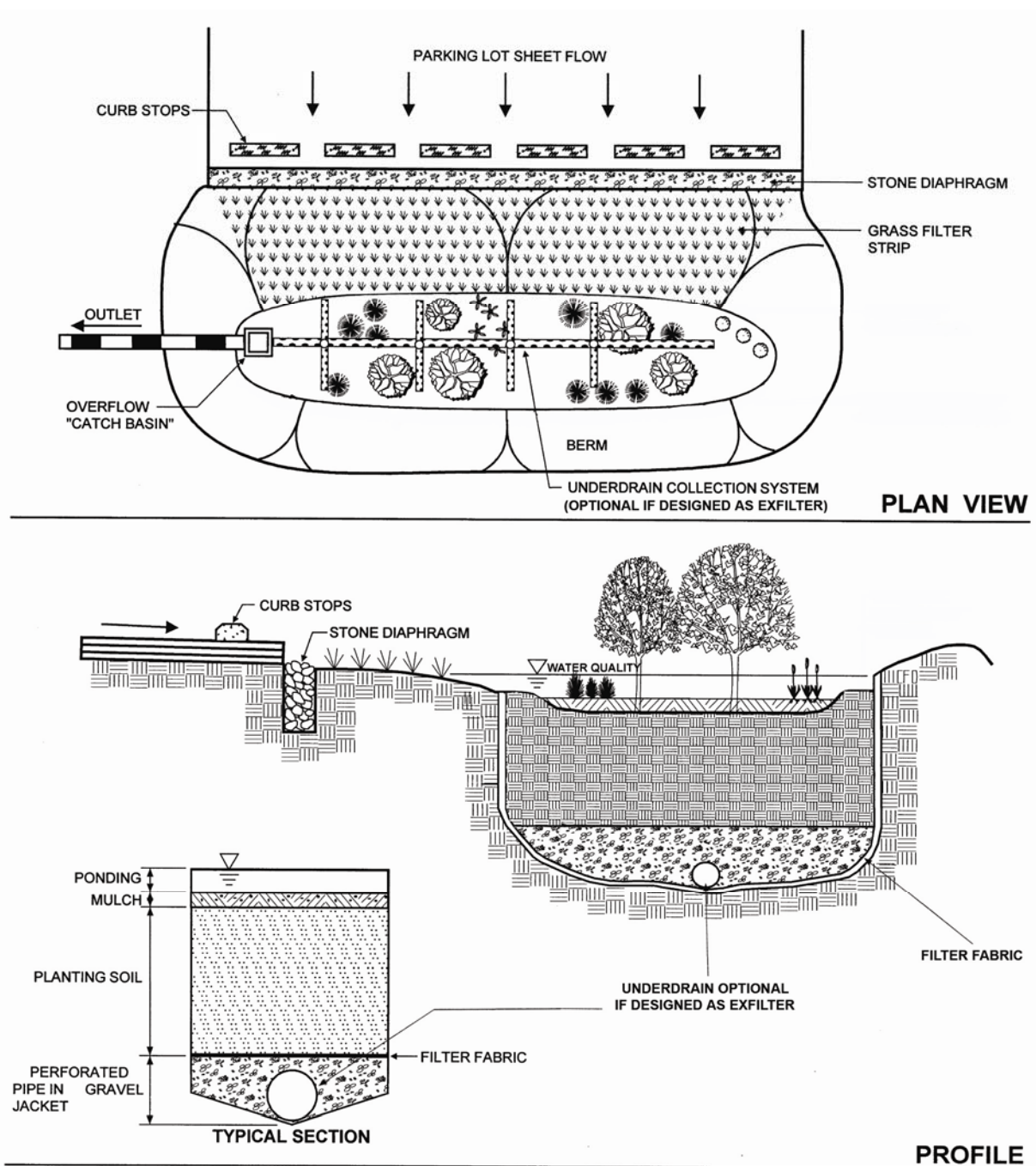

Figure 3.12 Bioretention (F-3)

#### 3.2.4.4a *Feasibility* Design Guidance

- Most stormwater filters normally require four to six feet of head, depending on site configuration and land area available.
- The recommended maximum contributing area to an individual stormwater filtering system is usually less than 10 acres. In some situations, larger areas may be acceptable.
- Sand and organic filtering systems are generally applied to land uses with a high percentage of impervious surfaces. Sites with imperviousness less than 75% will require sedimentation pretreatment techniques (See **Section 3.2.4.4c**).

#### 3.2.4.4b *Conveyance* Required Elements

- If runoff is delivered by a storm drain pipe or is along the main conveyance system, the filtering practice shall be designed off-line. In these cases, a flow regulator (or flow splitter diversion structure) shall be supplied to divert the  $WQ_v$  to the filtering practice, and allow larger flows to bypass the practice.
- An overflow shall be provided for runoff greater than the  $WQ_v$  to a non-erosive outlet point (i.e., prevent downstream slope erosion).
- Stormwater filters shall be equipped with a minimum 4-in perforated pipe underdrain in a limestone aggregate layer, unless designing an exfiltrating system in which case an underdrain may not be necessary. A permeable filter fabric shall be placed between the limestone aggregate layer and the filter media.

#### 3.2.4.4c *Pretreatment* Required Elements

- Dry or wet pretreatment shall be provided prior to filter media equivalent to at least 25% of the computed  $WQ_v$ . The typical method is a sedimentation basin that has a length to width ratio of 1.5:1. Other pretreatment techniques are specified under design guidance to this section and also under **Section 3.2.4.3c**. Sedimentation basins shall have a minimum depth of 3.0 ft. The Camp-Hazen equation is used to compute the required surface area for sedimentation basins for sand and organic filters requiring pretreatment (WSDE, 1992) as follows:
- The required sedimentation basin area is computed using the following equation:

$$A_s = -(Q_o/W) * \ln (1-E)$$

where:

$A_s$	=	Sedimentation basin surface area (ft <sup>2</sup> )
$E$	=	sediment trap efficiency (use 90%)
$W$	=	particle settling velocity (ft/sec) (use 0.0004 ft/sec or 1.44 ft/hr)
$Q_o$	=	Discharge rate from basin = ( $WQ_v/24$ hr)

Equation reduces to

$$A_s = (0.066) (WQ_v) \text{ ft}^2$$

Design Guidance

- Adequate pretreatment for bioretention systems should incorporate all of the following: (a) grass filter strip below a level spreader or grass channel, (b) limestone aggregate diaphragm and (c) a mulch layer.
- The grass filter strip should be sized using the guidelines in **Table 3.6**.

**Table 3.6 Guidelines for Filter Strip Pretreatment Sizing**

Parameter	Impervious Parking Lots				Residential Lawns			
	35		75		75		150	
Maximum Inflow Approach Length (ft.)	35		75		75		150	
Filter Strip Slope	≤2%	≥2%	≤2%	≥2%	≤2%	≥2%	≤2%	≥2%
Filter Strip Minimum Length	10'	15'	20'	25'	10'	12'	15'	18'

- The grass channel can be sized using the following procedure:
  - Determine the volume needed to treat the  $WQ_v$  and multiply by 25% for pretreatment volume.
  - Choose the cross-sectional area of your channel (Assume trapezoidal channel with minimum of 2ft bottom width, 2:1 side slopes, and 1ft depth).
  - Determine the channel length by dividing the pretreatment volume by the cross-sectional area.

3.2.4.4d *Treatment*

Required Elements

- The entire treatment system (including pretreatment) shall be sized to temporarily hold at least 75% of the  $WQ_v$  prior to filtration (i.e.,  $V_{min} = 0.75 * WQ_v$ ).
- The filter media shall consist of a medium sand (crushed, washed limestone meeting ASTM C-33 concrete sand is acceptable). Media used for organic filters may consist of peat/sand mix or leaf compost. Peat shall be a reed-sedge hemic peat.
- Bioretention systems shall consist of the following treatment components: A 4-ft deep planting soil bed, a surface mulch layer, and a 6-in deep surface ponding area. Soils shall meet the design criteria outlined in **Volume II, Section 6.4**. The depth of bioretention systems may be reduced to 18in on a case-by-case basis as demonstrated by the designer that 4 ft is not feasible, such as sites with high groundwater or shallow depth to clay soils, or in retrofit situations where pre-existing site constraints exist.

### Design Guidance

- Sand and organic filter beds typically have a minimum depth of 18 inches. A minimum filter bed depth of 12 inches may be approved on a case-by-case basis as demonstrated by the designer that 18 inches is not feasible, particularly in retrofit cases.
- The filter area for sand and organic filters should be sized based on the principles of Darcy's Law. A coefficient of permeability (k) should be used as follows:

Sand:	3.5 ft/day (City of Austin, 1988)
Peat:	2.0 ft/day (Galli, 1990)
Leaf compost:	8.7 ft/day (Claytor and Schueler, 1996)
Bioretention Soil:	1.0 ft/day for sandy-loam soils

The required filter bed area is computed using the following equation:

$$A_f = (WQ_v) (d_f) / [(k) (h_f + d_f) (t_f)]$$

Where:

- $A_f$  = Surface area of filter bed (ft<sup>2</sup>)
- $d_f$  = Filter bed depth (ft)
- $k$  = Coefficient of permeability of filter media (ft/day)
- $h_f$  = Average height of water above filter bed (ft)
- $t_f$  = Design filter bed drain time (days)  
(1.67 days or 40 hours is recommended maximum  $t_f$  for sand filters; 2 days for bioretention)

#### 3.2.4.4e *Landscaping*

##### Required Elements

- A dense and vigorous vegetative cover shall be established over the contributing pervious drainage areas before runoff can be accepted into the facility.
- Landscaping is critical to the performance and function of bioretention areas. Therefore, a landscaping plan must be provided for bioretention areas (See **Volume II-Chapter 5**).

### Design Guidance

- Sand and organic filters can have a grass cover to aid in pollutant adsorption. The grass should be capable of withstanding frequent periods of inundation and drought.
- Planting recommendations for bioretention facilities are as follows:
  - Native plant species should be specified over non-native species.
  - Vegetation should be selected based on a specified zone of hydric tolerance.
  - A selection of trees with an understory of shrubs and herbaceous materials should be provided.
  - Woody vegetation should not be specified at inflow locations.
  - Trees should be planted primarily along the perimeter of the facility.

- A tree density of approximately one tree per 100 ft<sup>2</sup> (i.e., 10 ft on-center) is recommended. Shrubs and herbaceous vegetation should generally be planted at higher densities (5 ft on-center and 2.5 ft on center, respectively).

#### 3.2.4.4f *Maintenance*

##### Required Elements

- A legally binding and enforceable maintenance agreement shall be executed between the facility owner and the local review authority to ensure the following:
  - Sediment shall be cleaned out of the sedimentation chamber when it accumulates to a depth of more than 12 inches. Vegetation within the sedimentation chamber shall be limited to a height of 18 inches. The sediment chamber outlet devices shall be cleaned/repared when drawdown times exceed 36 hours. Trash and debris shall be removed as necessary.
  - Silt/sediment shall be removed from the filter bed when the accumulation exceeds one inch. When the filtering capacity of the filter diminishes substantially (i.e., when water ponds on the surface of the filter bed for more than 48 hours), the top few inches of discolored material shall be removed and shall be replaced with fresh material. The removed sediments shall be disposed in an acceptable manner (i.e., landfill).

##### Design Guidance

- Organic filters or sand filters that have a grass cover should be mowed a minimum of three times per growing season to maintain maximum grass heights less than 12 inches.
- A stone drop or diaphragm (see **Figure 3.12**) of at least six inches should be provided at the inlet of bioretention facilities (washed, rounded limestone aggregate diaphragm. Areas devoid of mulch shall be re-mulched on an annual basis. Dead or diseased plant material shall be replaced.



**Filters**



**Description:** Multi-chamber structure designed to treat stormwater runoff through filtration, using a sediment forebay, a primary filter media and, typically, an underdrain collection system.

Design Practices: Sand filter (F-1) and Organic filter (F-2)

**KEY CONSIDERATIONS**

**CONVEYANCE**

- If stormwater is delivered by stormdrain, design off-line. For off-line facilities, flow regulator is needed to divert  $WQ_v$  to the practice and to bypass larger flows.
- Overflow for the 2-year storm to a non-erosive point.
- Underdrain (4" perforated pipe minimum) unless designed as exfilter system.

**PRETREATMENT**

- Pretreatment volume of 25% of  $WQ_v$ .
- Typically a sediment basin with a 1.5:1 L:W ratio, sized with the Camp-Hazen equation (See **Section 3.2.4.4c**).

**TREATMENT**

- System must hold 75% of the  $WQ_v$ .
- Filter media shall be ASTM C-33 sand for sand filters.
- Organic filters shall be a peat/sand mix, or leaf compost.
- Peat shall be reed-sedge hemic peat.

**LANDSCAPING**

- Contributing area stabilized before runoff is directed to the facility.

**STORMWATER MANAGEMENT SUITABILITY**

- Water Quality
- Recharge (if designed as an exfilter system)
- Channel Protection
- Overbank Flood Control

**Accepts Hotspot Runoff:** *Yes (requires impermeable liner for water quality treatment, 100% pretreatment for recharge)*

**IMPLEMENTATION CONSIDERATIONS**

- H** Capital Cost
- H** Maintenance Burden

**Residential/Subdivision Use:** *No*  
**High Density/Ultra-Urban:** *Yes*

**Drainage Area:** *2-10 acres max.*

**Soils:** *No restrictions*

**Other Considerations:**

Typically needs to be combined with other controls to provide water quantity control

**Key:** L=Low M=Moderate H=High

<p><b>MAINTENANCE REQUIREMENTS:</b></p> <ul style="list-style-type: none"> <li>• Legally binding maintenance agreement.</li> <li>• Sediment cleaned out of sedimentation chamber when it reaches more than 12” in depth.</li> <li>• Vegetation limited to 18”.</li> <li>• Sediment chamber cleaned if drawdowns exceed 36 hours.</li> <li>• Trash and debris removal.</li> <li>• Silt/sediment removed from filter bed after it reaches one inch.</li> <li>• If water ponds on the filter bed for greater than 48 hours, remove material, and replace.</li> </ul>	<p><b><u>POLLUTANT REMOVAL</u></b></p> <p><b>G</b> Phosphorus</p> <p><b>G</b> Nitrogen</p> <p><b>G</b> Metals - Cadmium, Copper, Lead, and Zinc removal</p> <p><b>F</b> Pathogens - Coliform, <i>Streptococci</i>, <i>E. coli</i> removal</p> <p><b>Key: G=Good F=Fair P=Poor</b></p>
---	---

**Bioretention Areas**



**Description:** Shallow stormwater basin or landscaped area that utilizes engineered soils and vegetation to capture and treat runoff. The practice is often located in parking lot islands and can also be used to treat residential areas.

Design Practices: Bioretention (F-3)

<p style="text-align: center;"><b><u>KEY CONSIDERATIONS</u></b></p> <p><b>CONVEYANCE</b></p> <ul style="list-style-type: none"> <li>• Provide overflow for the 2-year storm to the conveyance system.</li> <li>• Conveyance to the system is typically overland flow delivered to the surface of the system, typically through curb cuts or over a concrete lip.</li> </ul> <p><b>PRETREATMENT</b></p> <ul style="list-style-type: none"> <li>• Pretreatment consists of a grass channel or grass filter strip, a limestone aggregate diaphragm, and a mulch layer, sized based on the methodologies described in <b>Section 3.2.4.4c.</b></li> </ul> <p><b>TREATMENT</b></p> <ul style="list-style-type: none"> <li>• Treatment area should generally have a four-foot deep planting soil bed, a surface mulch layer, and a 6” ponding layer.</li> <li>• Size the treatment area using equations provided in <b>Section 3.2.4.4d.</b></li> </ul> <p><b>LANDSCAPING</b></p> <ul style="list-style-type: none"> <li>• Detailed landscaping plan required.</li> </ul>	<p style="text-align: center;"><b><u>STORMWATER MANAGEMENT SUITABILITY</u></b></p> <ul style="list-style-type: none"> <li><input checked="" type="checkbox"/> Water Quality</li> <li><input checked="" type="checkbox"/> Recharge</li> <li><input type="checkbox"/> Channel Protection</li> <li><input type="checkbox"/> Overbank Flood Control</li> </ul> <p><b>Accepts Hotspot Runoff:</b> <i>Yes (requires impermeable liner for water quality treatment, 100% pretreatment for recharge)</i></p> <p style="text-align: center;"><b><u>IMPLEMENTATION CONSIDERATIONS</u></b></p> <ul style="list-style-type: none"> <li><input style="border: 1px solid black; padding: 2px; margin-right: 5px;" type="checkbox"/> <b>Capital Cost</b></li> <li><input style="border: 1px solid black; padding: 2px; margin-right: 5px;" type="checkbox"/> <b>Maintenance Burden</b></li> </ul> <p><b>Residential/Subdivision Use:</b> <i>Yes</i>  <b>High Density/Ultra-Urban:</b> <i>Yes</i>  <b>Drainage Area:</b> <i>5 acres max.</i>  <b>Soils:</b> <i>Planting soils must meet specified criteria; No restrictions on surrounding soils, except the depth above water table.</i></p> <p><b>Other Considerations:</b></p> <ul style="list-style-type: none"> <li>▶ Use of native plants is recommended</li> </ul> <div style="border: 1px solid black; padding: 5px; text-align: center; margin-top: 10px;"> <p><b>Key: L=Low M=Moderate H=High</b></p> </div>
---	--

**MAINTENANCE REQUIREMENTS:**

- Inspect and repair/replace treatment area components.
- Stone drop/diaphragm (at least 6”) provided at the inlet.
- Remulch annually.
- Vegetation pruning, harvesting.

**POLLUTANT REMOVAL**

**G**

**Phosphorus**

**G**

**Nitrogen**

**G**

**Metals** - Cadmium, Copper, Lead, and Zinc removal

**F**

**Pathogens** - Coliform, *Streptococci*, *E. coli* removal

**Key: G=Good F=Fair P=Poor**

### 3.2.4.5 Open Channel Systems

Open channel systems are vegetated open channels that are explicitly designed to capture and treat the full  $WQ_v$  within dry or wet cells formed by check dams or other means. Design variants include:

- O-1 Dry Swale (Figure 3.13)
- O-2 Wet Swale (Figure 3.14)

Treatment Suitability: Open Channel Systems can meet water quality treatment goals only, and are not appropriate for  $Cp_v$  or  $Q_{p-25}$ .

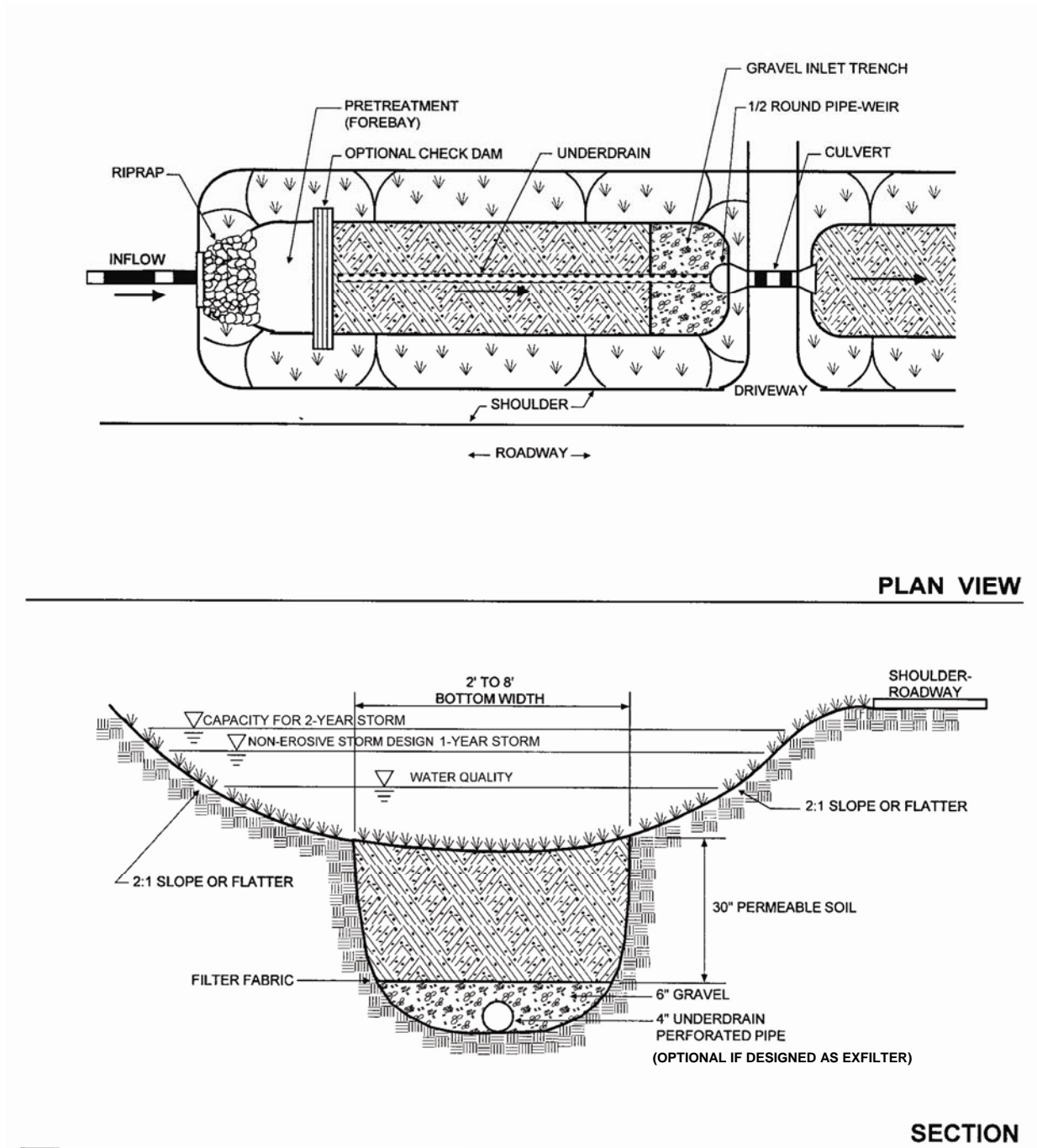
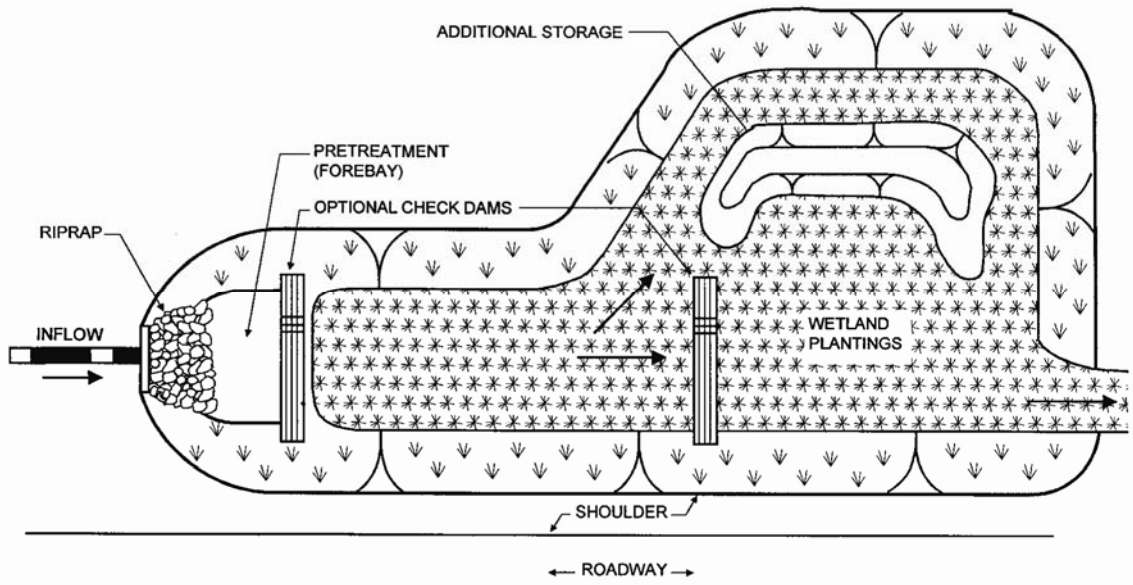
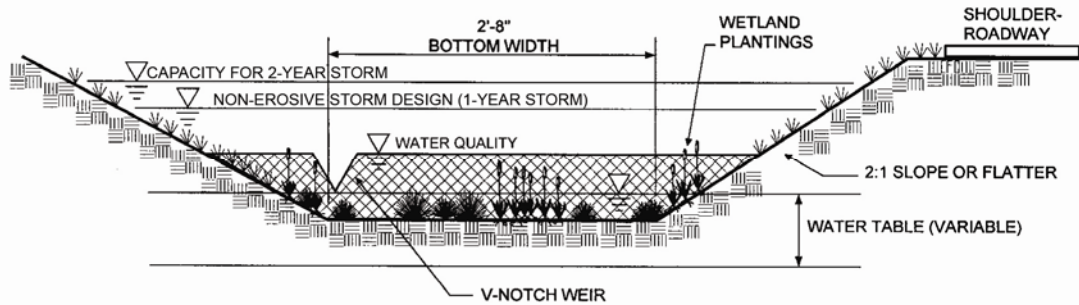

Figure 3.13 Dry Swale (O-1)



**PLAN VIEW**



**PROFILE**

**Figure 3.14 Wet Swale (O-2)**

#### 3.2.4.5a *Feasibility*

##### Required Elements

- The system shall have a maximum longitudinal slope of 4.0%.

##### Design Guidance

- Dry Swales are primarily applicable for land uses such as roads, highways, residential development, and pervious areas.
- Wet Swales should be restricted in residential areas because of the potential for stagnant water and other nuisance ponding.

#### 3.2.4.5b *Conveyance*

##### Required Elements

- The peak velocity for the 1-year storm must be non-erosive (i.e., 3.5-5.0 fps).
- Open channels shall be designed to safely convey the 2-year storm with a minimum of 6 inches of freeboard.
- The maximum allowable temporary ponding time within a channel shall be less than 48 hours. An underdrain system shall be used in the dry swale to ensure this ponding time, unless designed as an exfilter in which case an underdrain may not be necessary.
- Channels shall be designed with moderate side slopes (flatter than 3:1) for most conditions. Designers may utilize a 2:1 maximum side slope, where 3:1 slopes are not feasible.

##### Design Guidance

- Open channel systems which directly receive runoff from non-roadway impervious surfaces may have a 6-inch drop onto a protected shelf (washed, rounded limestone aggregate diaphragm) to minimize the clogging potential of the inlet. Runoff from roads shall drain over a vegetative slope prior to flowing into a swale.
- The underdrain system should be composed of a 6-in limestone aggregate bed with a 4-in PVC pipe.
- If the site slope is greater than 2%, check dams may be needed to retain the water quality volume within the swale system.

#### 3.2.4.5c *Pretreatment*

##### Required Elements

- Provide 10% of the  $WQ_v$  in pretreatment. This storage is usually obtained by providing checkdams at pipe inlets and/or driveway crossings. Road drainage entering a swale along the length of the road may pre-treat runoff using a vegetative filter strip. An effective filter strip shall be no steeper than 6% slope and 4 ft wide for each travel lane draining to the swale.

##### Design Guidance



- Utilize a washed, rounded limestone aggregate diaphragm and gentle side slopes along the top of channels to provide pretreatment for lateral sheet flows.

#### 3.2.4.5d *Treatment*

##### Required Elements

- Temporarily store the  $WQ_v$  within the facility to be released over a minimum 30-minute duration.
- Design with a bottom width no greater than 8 ft to avoid potential gullyng and channel braiding, but no less than 2 ft.
- Soil media for the dry swale shall meet the specifications outlined in **Volume II-Chapter 6**.

##### Design Guidance

- Open channels should maintain a maximum ponding depth of one foot at the mid-point of the channel, and a maximum depth of 18 in at the end point of the channel (for storage of the  $WQ_v$ ).

#### 3.2.4.5e *Landscaping*

##### Design Guidance

- Landscape design should specify proper grass species and wetland plants based on specific site, soils and hydric conditions present along the channel. (See **Volume II-Chapter 5** for landscaping guidance for CNMI and Guam).

#### 3.2.4.5f *Maintenance*

##### Required Elements

- A legally binding and enforceable maintenance agreement shall be executed between the facility owner and the local review authority to ensure the following:
  - Sediment build-up within the bottom of the channel or filter strip is removed when 25% of the original  $WQ_v$  volume has been exceeded.
  - Vegetation in dry swales is mowed as required to maintain grass heights in the 4-6 in range, with mandatory mowing once grass heights exceed 10 in.

**<This page left blank intentionally>**

**Open Channels**



**Description:** Vegetated channels that are explicitly designed and constructed to capture and treat stormwater runoff within dry or wet cells formed by check dams or other means.

Design Practices: Dry Swale (O-1) and Wet Swale (O-2)

<p style="text-align: center;"><b><u>KEY CONSIDERATIONS</u></b></p> <p><b>FEASIBILITY</b></p> <ul style="list-style-type: none"> <li>Maximum longitudinal slope of 4%.</li> </ul> <p><b>CONVEYANCE</b></p> <ul style="list-style-type: none"> <li>Non-erosive (3.5 to 5.0 fps) peak velocity for the 1-year storm.</li> <li>Safe conveyance of the 2-year storm with a minimum of 6 inches of freeboard.</li> <li>Side slopes gentler than 2:1 (3:1 preferred).</li> <li>The maximum allowable temporary ponding time of 48 hours.</li> </ul> <p><b>PRETREATMENT</b></p> <ul style="list-style-type: none"> <li>10% of the WQ<sub>v</sub> in pretreatment, usually provided using check dams at culverts or driveway crossings.</li> </ul> <p><b>TREATMENT</b></p> <ul style="list-style-type: none"> <li>Temporary storage for the WQ<sub>v</sub> within the facility to be released over a minimum 30 minute duration.</li> <li>Bottom width no greater than 8 feet, but no less than two feet.</li> <li>Soil media as detailed in <b>Volume II, Chapter 6</b>.</li> </ul>	<p style="text-align: center;"><b><u>STORMWATER MANAGEMENT SUITABILITY</u></b></p> <ul style="list-style-type: none"> <li><input checked="" type="checkbox"/> Water Quality</li> <li><input checked="" type="checkbox"/> Recharge</li> <li><input type="checkbox"/> Channel Protection</li> <li><input type="checkbox"/> Overbank Flood Control</li> </ul> <p><b>Accepts Hotspot Runoff:</b> <i>Yes</i> (requires impermeable liner for water quality treatment, 100% pretreatment for recharge)</p> <p style="text-align: center;"><b><u>IMPLEMENTATION CONSIDERATIONS</u></b></p> <ul style="list-style-type: none"> <li><input type="checkbox"/> Capital Cost</li> <li><input type="checkbox"/> Maintenance Burden</li> </ul> <p><b>Residential/Subdivision Use:</b> <i>Yes</i> <b>High Density/Ultra-Urban:</b> <i>No</i> <b>Drainage Area:</b> <i>5 acres max.</i> <b>Soils:</b> <i>No restrictions</i> <b>Other Considerations:</b></p> <ul style="list-style-type: none"> <li>Permeable soil layer (dry swale)</li> <li>Wetland plants (wet swale)</li> </ul> <p style="text-align: center; border: 1px solid black; padding: 2px;"><b>Key: L=Low M=Moderate H=High</b></p>
--	--

**MAINTENANCE REQUIREMENTS:**

- Removal of sediment build-up within the bottom of the channel when 25% of the original  $WQ_v$  volume has been exceeded.
- Maintain an average grass height of 6” in dry swales and grass channels.
- Correct erosion gullies and maintain healthy stand of vegetation.

**POLLUTANT REMOVAL**

- G** **Phosphorus**
- G** **Nitrogen**
- G** **Metals - Cadmium, Copper, Lead, and Zinc removal**
- F** **Pathogens - Coliform, Streptococci, E. coli removal**

**Key: G=Good F=Fair P=Poor**

### 3.2.4.6 Limited Applicability Stormwater Management Practices

As previously described, there is a suite of stormwater management practices that have limited applicability either because they only provide water quantity control capabilities or because they have limited water quality treatment capabilities (i.e., current independent studies do not support their inclusion in the list of acceptable practices).

Design variants include:

- LA-1 Dry Detention Pond (Figure 3.15)
- LA-2 Underground Storage Vault (Figure 3.16)
- LA-3 Filter Strip (Figure 3.17)
- LA-4 Grass Channel (Figure 3.18)
- LA-5 Hydrodynamic/Swirl Concentrator Devices (Figure 3.19)
- LA-6 Oil and Grit Separators (Figure 3.20)

**Treatment Suitability:** Dry detention ponds (LA-1) and underground storage vaults (LA-2) are designed to provide channel protection ( $C_{p_v}$ ), and overbank ( $Q_{p-25}$ ) flood control only. They are not suitable for meeting water quality or recharge criteria.

Filter strips (LA-3) and Grass Channels (LA-4) are appropriate for pretreatment.

Hydrodynamic/swirl concentrator devices (LA-5) are appropriate for pretreatment requirements only and do not meet the full water quality requirement or the recharge requirement.

Oil and grit separators (LA-6) are presented in this section as a potential spill containment practice that might be used for hotspot land uses. These practices do not meet water quality, recharge, or pretreatment requirements.

Design guidance is provided for these limited application practices; however, not at the same level of detail as the practices acceptable to meet water quality requirements. In cases where the practice is a proprietary product, specifications and design criteria can typically be obtained from vendors.

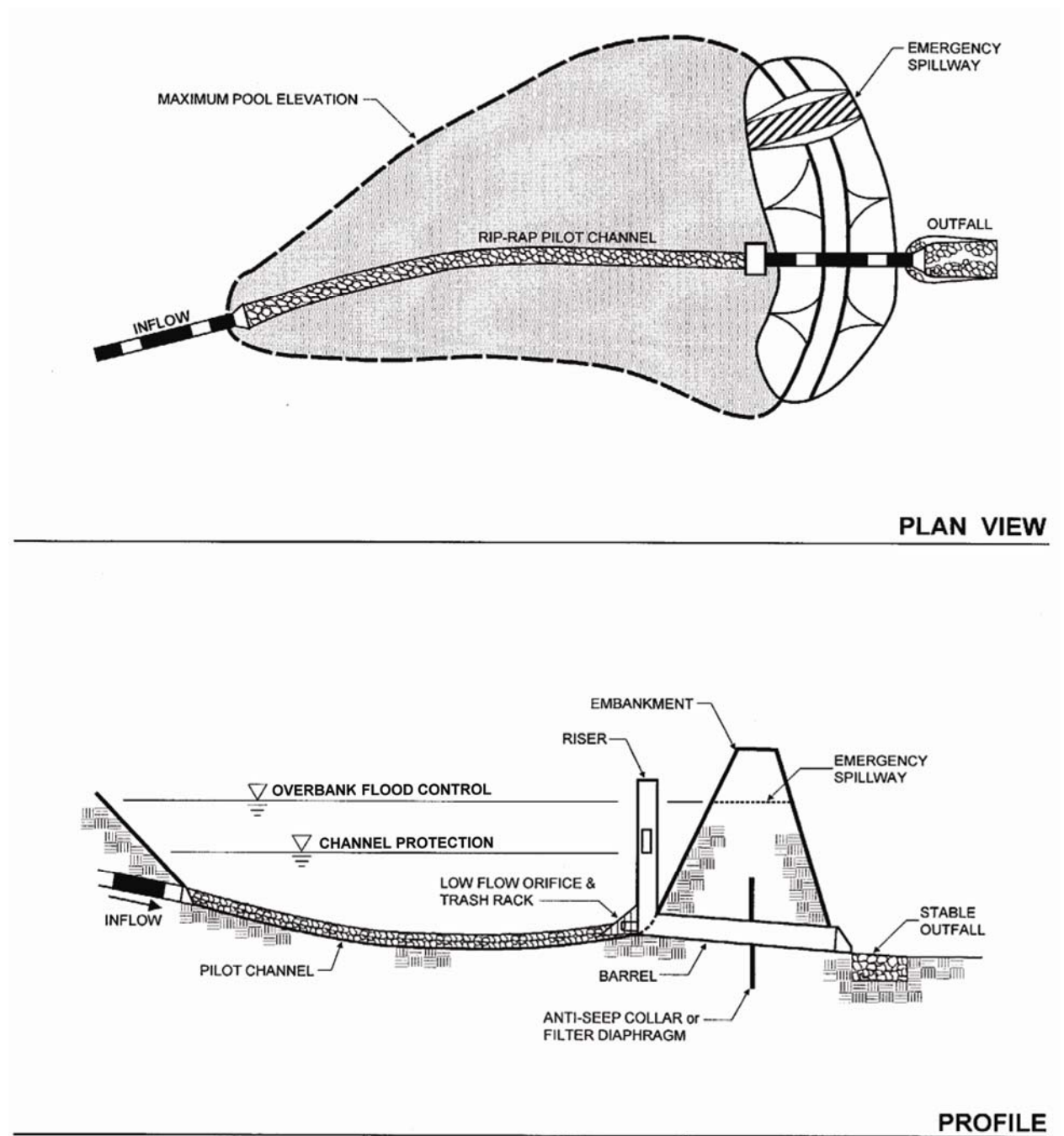

Figure 3.15 Dry Detention Pond (LA-1)

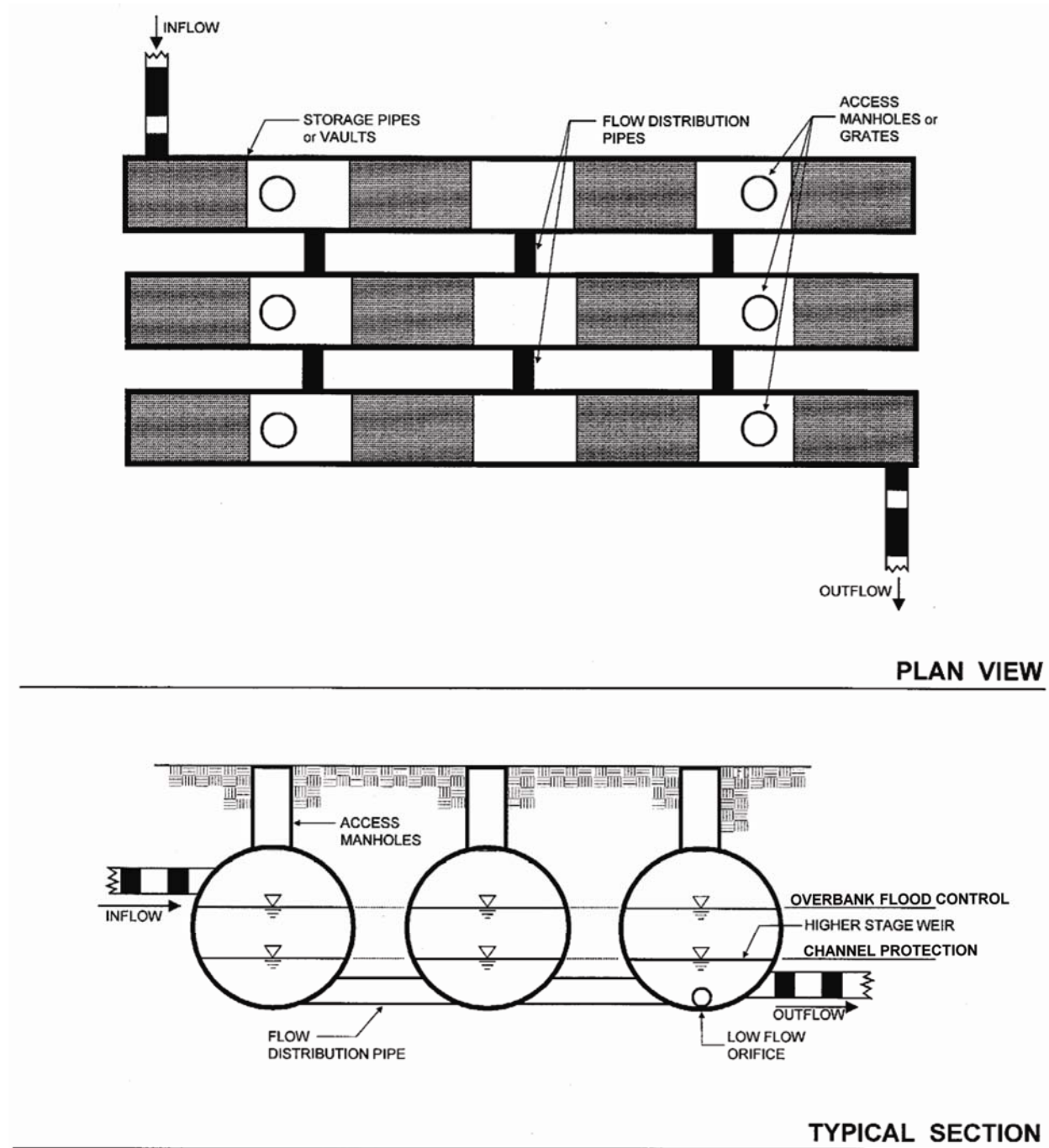
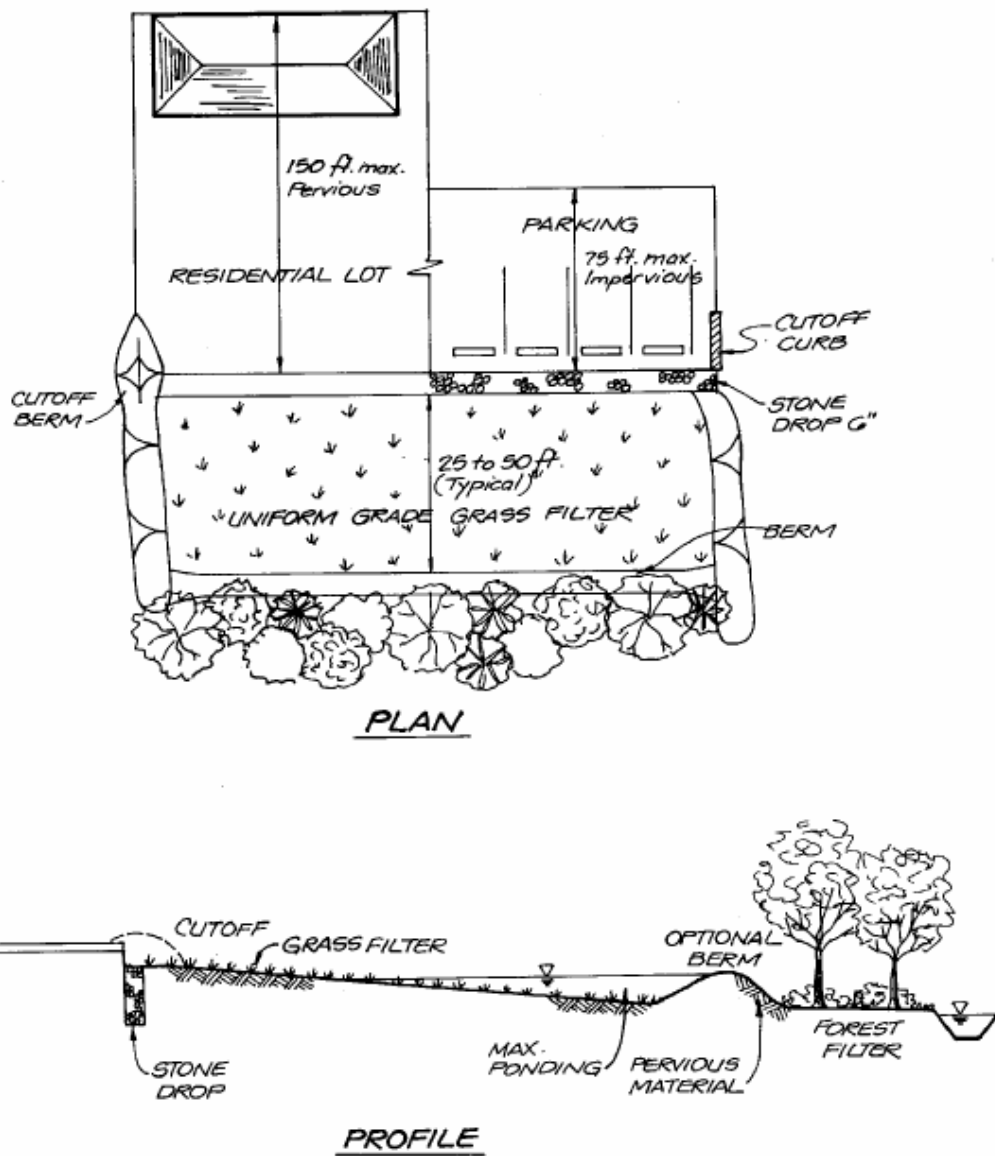
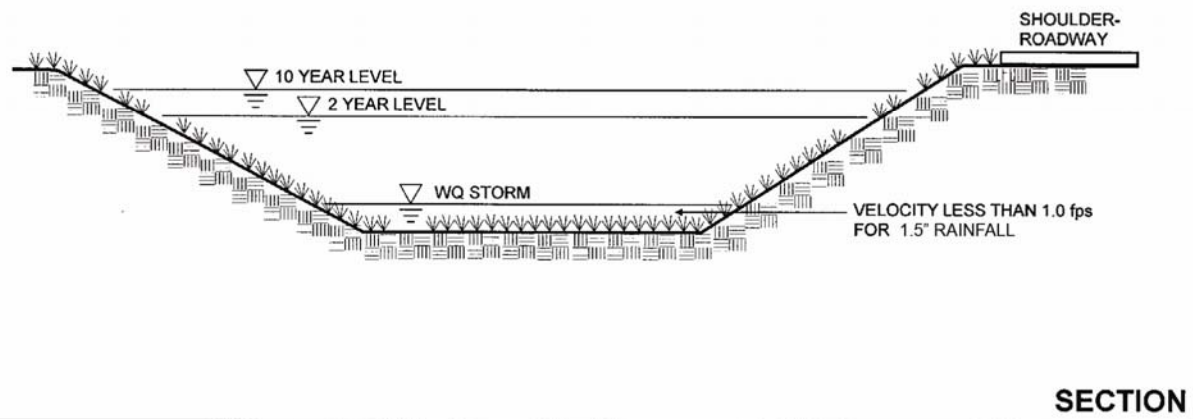
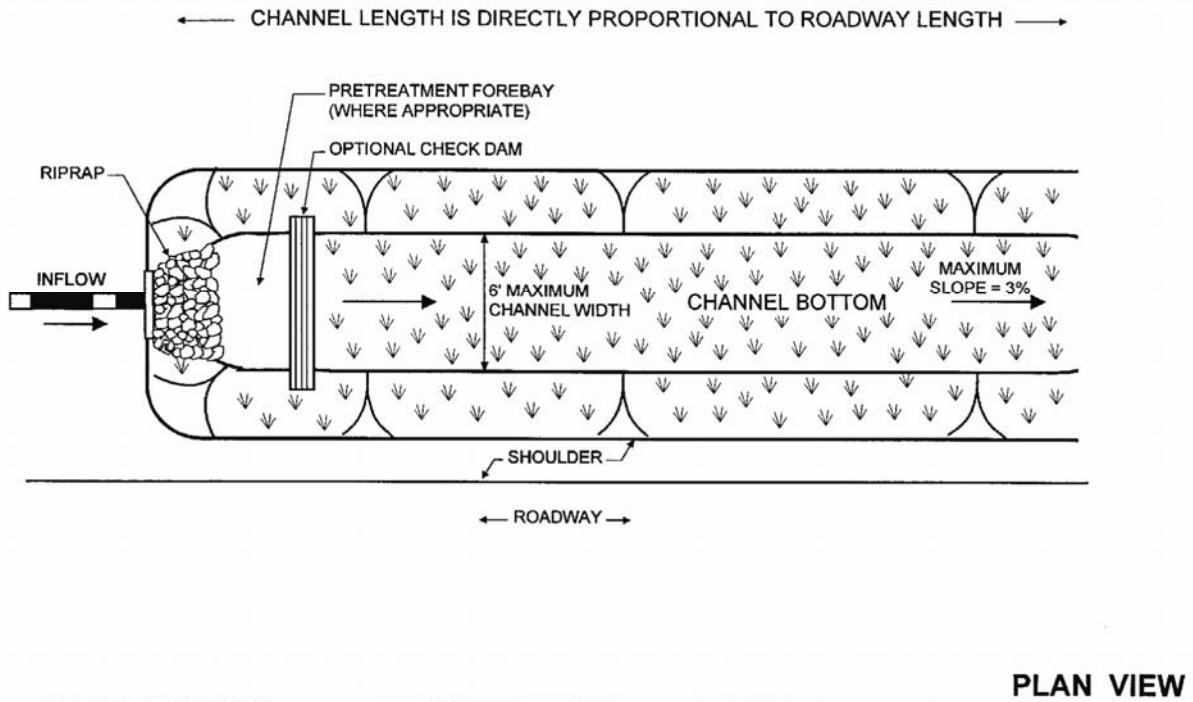

Figure 3.16 Underground Storage Vault (LA-2)

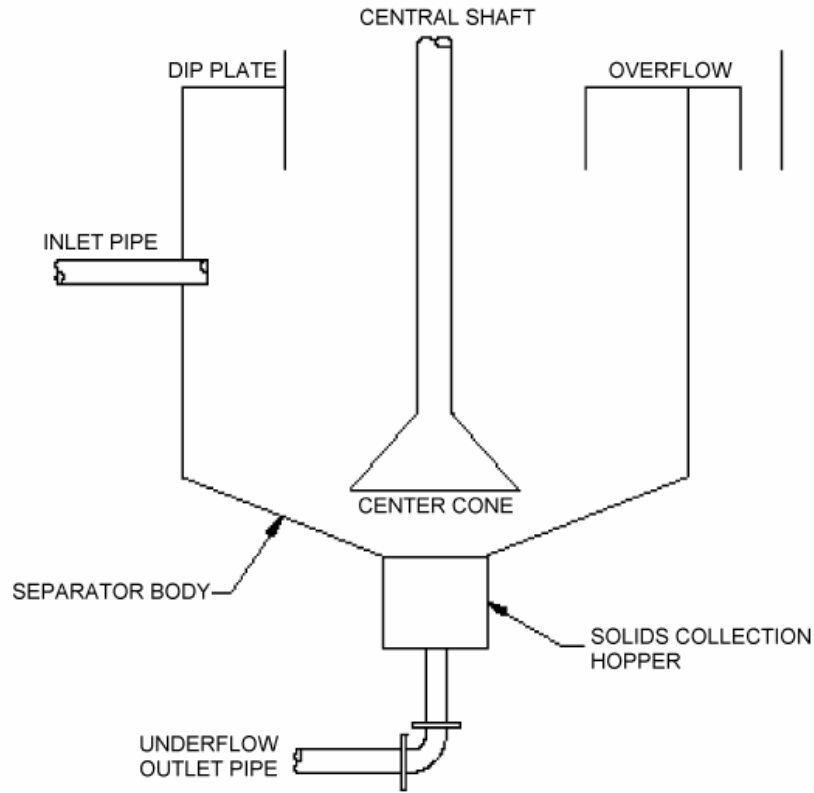

**Figure 3.17 Filter Strip (LA-3)**

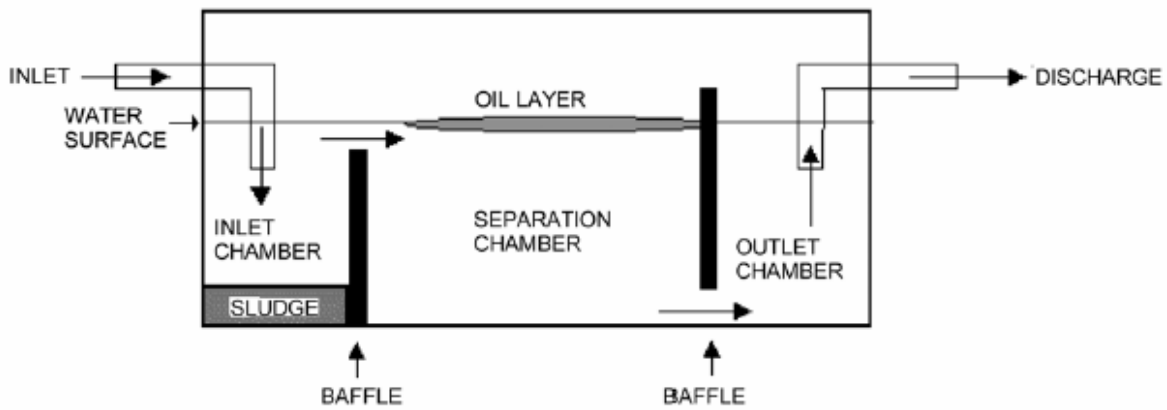



**Figure 3.18 Grass Channel (LA-4)**



**Figure 3.19 Hydrodynamic Device (LA-5)**



**Figure 3.20 Oil and Grit Separator (LA-6)**



## ***GLOSSARY***

ANTI-SEEP COLLAR - An impermeable diaphragm usually of sheet metal or concrete constructed at intervals within the zone of saturation along the conduit of a principal spillway to increase the seepage length along the conduit and thereby prevent piping or seepage along the conduit.

AQUATIC BENCH - A ten- to fifteen-foot wide bench which is located around the inside perimeter of a permanent pool and is normally vegetated with aquatic plants; the goal is to provide pollutant removal and enhance safety in areas using stormwater ponds.

AQUIFER - A geological formation that contains and transports groundwater.

BANKFULL FLOW - The condition where streamflow just fills a stream channel up to the top of the bank and at a point where the water begins to overflow onto a floodplain.

BARREL - The closed conduit used to convey water under or through an embankment: part of the principal spillway.

BERM - A shelf that breaks the continuity of a slope; a linear embankment or dike.

BIORETENTION - A water quality practice that utilizes landscaping and soils to treat urban stormwater runoff by collecting it in shallow depressions, before filtering through a fabricated planting soil media.

CHANNEL - A natural stream that conveys water; a ditch or channel excavated for the flow of water.

CHANNEL PROTECTION ( $C_{pv}$ ) - A design criteria which requires 24-hour detention of the one-year post-developed, 24-hour storm event for the control of stream channel and overland erosion.

CHANNEL STABILIZATION - Erosion prevention and stabilization of velocity distribution in a channel using jetties, drops, revetments, structural linings, vegetation and other measures.

CHECK DAM - A small dam construction in a gully or other small watercourse to decrease the stream flow velocity (by reducing the channel gradient), minimize channel scour, and promote deposition of sediment.

CHUTE - A high velocity, open channel for conveying water to a lower level without erosion.

CLAY (SOILS) - 1. A mineral soil separate consisting of particles less than 0.002 millimeter in equivalent diameter. 2. A soil texture class. 3. (Engineering) A fine-grained soil (more than 50 percent passing the No. 200 sieve) that has a high plasticity index in relation to the liquid limit. (Unified Soil Classification System)

COCONUT ROLLS - Also known as coir rolls, these are rolls of natural coconut fiber designed for use in streambank stabilization.

COMMERCIAL CONTAINER NURSERY - A commercial nursery that grows herbaceous plants, shrubs, and trees in containers on their lot rather than in the ground.

COMPACTION (SOILS) - Any process by which the soil grains are rearranged to decrease void space and bring them in closer contact with one another, thereby increasing the weight of solid material per unit of volume, increasing the shear and bearing strength and reducing permeability.

CONDUIT - Any channel intended for the conveyance of water, whether open or closed.

CONTOUR - 1. An imaginary line on the surface of the earth connecting points of the same elevation. 2. A line drawn on a map connecting points of the same elevation.

CREST - 1. The top of a dam, dike, spillway or weir, frequently restricted to the overflow portion. 2. The summit of a wave or peak of a flood.

CRUSHED STONE - Aggregate consisting of angular particles produced by mechanically crushing rock.

CURVE NUMBER (CN) - A numerical representation of a given area's hydrologic soil group, plant cover, impervious cover, interception and surface storage derived in accordance with Natural Resources Conservation Service methods. This number is used to convert rainfall volume into runoff volume.

DAM - A barrier to confine or raise water for storage or diversion, to create a hydraulic head, to prevent gully erosion, or for retention of soil, sediment or other debris.

DETENTION - The temporary storage of storm runoff in a BMP with the goals of controlling peak discharge rates and providing gravity settling of pollutants.

DETENTION STRUCTURE - A structure constructed for the purpose of temporary storage of stream flow or surface runoff and gradual release of stored water at controlled rates.

DIAPHRAGM - A stone trench filled with small, washed rounded limestone aggregate used as pretreatment and inflow regulation in stormwater filtering systems.

DIKE - An embankment to confine or control water, for example, one built along the banks of a river to prevent overflow or lowlands; a levee.

DISTURBED AREA - An area in which the natural vegetative soil cover has been removed or altered and, therefore, is susceptible to erosion.

DIVERSION - A channel with a supporting ridge on the lower side constructed across the slope to divert water from areas where it is in excess to sites where it can be used or disposed of safely. Diversions differ from terraces in that they are individually designed.

DRAINAGE - 1. The removal of excess surface water or ground water from land by means of surface or subsurface drains. 2. Soils characteristics that affect natural drainage.

DRAINAGE AREA (WATERSHED) - All land and water area from which runoff may run to a common (design) point.

DRY SWALE - An open drainage channel explicitly designed to detain and promote the filtration of stormwater runoff through an underlying fabricated soil media.

**EMERGENCY SPILLWAY** - A dam spillway designed and constructed to discharge flow in excess of the principal spillway design discharge.

**EROSION** - 1. The wearing away of the land surface by running water, wind, ice, or other geological agents, including such processes as gravitational creep. 2. Detachment and movement of soil or rock fragments by water, wind, ice or gravity. The following terms are used to describe different types of water erosion:

**Accelerated erosion** - Erosion much more rapid than normal, natural or geologic erosion, primarily as a result of the influence of the activities of man or, in some cases, of other animals or natural catastrophes that expose base surfaces, for example, fires.

**Gully erosion** - The erosion process whereby water accumulates in narrow channels and, over short periods, removes the soil from this narrow area to considerable depths, ranging from 1 or 2 feet to as much as 75 to 100 feet.

**Rill erosion** - An erosion process in which numerous small channels only several inches deep are formed. See rill.

**Sheet erosion** - The spattering of small soil particles caused by the impact of raindrops on wet soils. The loosened and spattered particles may or may not subsequently be removed by surface runoff.

**EROSIVE VELOCITIES** - Velocities of water that are high enough to wear away the land surface. Exposed soil will generally erode faster than stabilized soils. Erosive velocities will vary according to the soil type, slope, structural, or vegetative stabilization used to protect the soil.

**EUTROPHICATION** - Eutrophication is a process whereby water bodies receive excess nutrients that stimulate excessive plant growth (algae, periphyton attached algae, and nuisance plants weeds). This enhanced plant growth, often called an algal bloom, reduces dissolved oxygen in the water when dead plant material decomposes and can cause other organisms to die. Nutrients can come from many sources, such as fertilizers applied to agricultural fields, golf courses, and suburban lawns; deposition of nitrogen from the atmosphere; erosion of soil containing nutrients; and sewage treatment plant discharges.

**EXFILTRATION** - The downward movement of water through the soil; the downward flow of runoff from the bottom of an infiltration BMP into the soil.

**EXTENDED DETENTION (ED)** - A stormwater design feature that provides for the gradual release of a volume of water over a 12 to 48 hour interval in order to increase settling of urban pollutants and protect downstream channels from frequent storm events.

**FILTER BED** - The section of a constructed filtration device that houses the filter media and the outflow piping.

**FILTER FENCE** - A geotextile fabric designed to trap sediment and filter runoff.

**FILTER MEDIA** - The sand, soil, or other organic material in a filtration device used to provide a permeable surface for pollutant and sediment removal.

**FILTER STRIP** - A strip of permanent vegetation above ponds, diversions and other structures to retard flow of runoff water, causing deposition of transported material, thereby reducing sediment flow.

**FLOODPLAIN** - Areas adjacent to a stream or river that are subject to flooding or inundation during a storm event that occurs, on average, once every 100 years (or has a likelihood of occurrence of 1/100 in any given year).

**FLOW SPLITTER** - An engineered, hydraulic structure designed to divert a percentage of storm flow to a BMP located out of the primary channel, or to direct stormwater to a parallel pipe system, or to bypass a portion of baseflow around a BMP.

**FOREBAY** - Storage space located near a stormwater BMP inlet that serves to trap incoming coarse sediments before they accumulate in the main treatment area.

**FREEBOARD (HYDRAULICS)** - The distance between the maximum water surface elevation anticipated in design and the top of retaining banks or structures. Freeboard is provided to prevent overtopping due to unforeseen conditions.

**GABION** - A flexible woven-wire basket composed of two to six rectangular cells filled with small stones. Gabions may be assembled into many types of structures such as revetments, retaining walls, channel liners, drop structures and groins.

**GRADE** - 1. The slope of a road, channel or natural ground. 2. The finished surface of a canal bed, roadbed, top of embankment, or bottom of excavation; any surface prepared for the support of construction, like paving or laying a conduit. 3. To finish the surface of a canal bed, roadbed, top of embankment or bottom of excavation.

**GRASS CHANNEL** - An open vegetated channel used to convey runoff and to provide treatment by filtering out pollutants and sediments.

**GRAVEL** - 1. Aggregate consisting of mixed sizes of ¼-inch to 3-inch particles that normally occur in or near old streambeds and have been worn smooth by the action of water. 2. A soil having particle sizes, according to the Unified Soil Classification System, ranging from the No. 4 sieve size angular in shape as produced by mechanical crushing.

**GRAVEL DIAPHRAGM** - A stone trench filled with small, river-run gravel used as pretreatment and inflow regulation in stormwater filtering systems.

**GRAVEL TRENCH** - A shallow excavated channel backfilled with gravel and designed to provide temporary storage and permit percolation of runoff into the soil substrate.

**GROUND COVER** - Plants that are low growing and provide a thick growth that protects the soil as well as providing some beautification of the area occupied.

**GULLY** - A channel or miniature valley cut by concentrated runoff through which water commonly flows only during and immediately after heavy rains. The distinction between gully and rill is one of depth. A gully is sufficiently deep that it would not be obliterated by normal tillage operations, whereas a rill is of lesser depth and would be smoothed by ordinary farm tillage.

**HEAD (HYDRAULICS)** - 1. The height of water above any plane of reference. 2. The energy, either kinetic or potential, possessed by each unit weight of a liquid expressed as the vertical height through which a unit weight would have to fall to release the average energy possessed. Used in various terms such as pressure head, velocity head, and head loss.

**HEMIC PEAT** - An organic material, usually derived from wetland vegetation that is moderately decomposed, has a moderate bulk density and modest porosity.

HI MARSH - A pondscaping zone within a stormwater wetland that exists from the surface of the normal pool to a six-inch depth and typically contains the greatest density and diversity of emergent wetland plants.

HOTSPOT - Area where land use or activities generate highly contaminated runoff, with concentrations of pollutants in excess of those typically found in stormwater.

HYDROGRAPH - A graph showing variation in stage (depth) or discharge of a stream of water over a period of time.

HYDROLOGIC SOIL GROUP (HSG) - A Natural Resource Conservation Service classification system in which soils are categorized into four runoff potential groups. The groups range from A soils, with high permeability and little runoff production, to D soils, which have low permeability rates and produce much more runoff.

IMPERVIOUS COVER (I) - Those surfaces in the urban landscape that cannot effectively infiltrate rainfall consisting of building rooftops, pavement, sidewalks, driveways, coral surfaces (e.g., driveways, lots, and yards), etc.

INFILL DEVELOPMENT - An “infill development site” shall be defined as meeting all of the following:

1. The site is currently predominately pervious.
2. The site is surrounded (on at least three sides) by existing development (not including roadways).
3. The site is served by a network of existing infrastructure and does not require the extension of utility lines or new public road construction to serve the property (a “utility extension” is defined as construction of a main-line water, sewer, gas, or other utility, and does not include individual service connections for the subject project).
4. The site is: two (2) acres or less, for residential (including single family and multi-family), commercial, industrial and multi-use.

INFILTRATION RATE ( $f_c$ ) - The rate at which stormwater percolates into the subsoil measured in inches per hour.

KARST - Topography characterized by regions of carbonaceous rock formations typified by limestone substrate and sinkholes.

LEVEL SPREADER - A device for distributing stormwater uniformly over the ground surface as sheet flow to prevent concentrated, erosive flows and promote infiltration.

MANNING’S FORMULA (HYDRAULICS) - A formula used to predict the velocity of water flow in an open channel or pipeline:

$$V = (1.486/n) R^{2/3} S^{1/2}$$

Where V is the mean velocity of flow in feet per second; R is the hydraulic radius; S is the slope of the energy gradient or for assumed uniform flow the slope of the channel, in feet per foot; and n is the roughness coefficient or retardance factor of the channel lining.

MICROPOOL - A smaller permanent pool that is incorporated into the design of larger stormwater ponds to avoid resuspension or settling of particles and minimize impacts to adjacent natural features.

MICROTOPOGRAPHY - The complex contours along the bottom of a shallow marsh system, providing greater depth variation, which increases the wetland plant diversity and increases the surface area to volume ratio of a stormwater wetland.

MULCH - Covering on surface of soil to protect and enhance certain characteristics, such as water retention qualities.

NATIONAL POLLUTANT DISCHARGE ELIMINATION SYSTEM - Established by Section 402 of the Clean Water Act, this federally mandated system is used for regulating point source and stormwater discharges.

OUTFALL - The point where water flows from a conduit, stream, or drain.

OFF-LINE - A stormwater management system designed to manage a storm event by diverting a percentage of stormwater events from a stream or storm drainage system.

ON-LINE - A stormwater management system designed to manage stormwater in its original stream or drainage channel.

ONE-YEAR STORM - A stormwater event which occurs on average once every year or statistically has a 100% chance on average of occurring in a given year.

ONE HUNDRED YEAR STORM - An extreme flood event which occurs on average once every 100 years or statistically has a 1% chance on average of occurring in a given year.

OPEN CHANNELS - Also known as swales, grass channels, and biofilters. These systems are used for the conveyance, retention, infiltration and filtration of stormwater runoff.

OUTLET - The point at which water discharges from such things as a stream, river, lake, tidal basin, pipe, channel or drainage area.

OUTLET CHANNEL - A waterway constructed or altered primarily to carry water from man-made structures such as terraces, subsurface drains, diversions and impoundments.

OUTLET CONTROL STRUCTURE - A hydraulic structure placed at the outlet of a channel, spillway, pond, etc., for the purpose of dissipating energy, providing a transition to the channel or pipe downstream, while achieving the discharge rates for specified designs.

PEAK DISCHARGE RATE - The maximum instantaneous rate of flow during a storm, usually in reference to a specific design storm event.

PERMANENT SEEDING - Results in establishing perennial vegetation that may remain on the area for many years.

PERMEABILITY - The rate of water movement through the soil column under saturated conditions.

PIPING - Removal of soil material through subsurface flow channels or “pipes” developed by seepage water.



POCKET WETLAND/POND - A stormwater wetland or pond design adapted for the treatment of runoff from small drainage areas (< 5 acres) and which has little or no baseflow available to maintain water elevations and relies on ground water to maintain a permanent pool.

POND BUFFER - The area immediately surrounding a pond that acts as filter to remove pollutants and provide infiltration of stormwater prior to reaching the pond. Provides a separation barrier to adjacent development.

POND DRAIN - A pipe or other structure used to drain a permanent pool within a specified time period.

PONDSCAPING - Landscaping around stormwater ponds that emphasizes native vegetative species to meet specific design intentions. Species are selected for up to six zones in the pond and its surrounding buffer, based on their ability to tolerate inundation and/ or soil saturation.

POROSITY - Ratio of pore volume to total solids volume.

PRETREATMENT - Techniques employed in stormwater BMPs to provide storage or filtering to help trap coarse materials before they enter the system.

PRINCIPAL SPILLWAY - The primary pipe or weir that carries baseflow and storm flow through the embankment.

RECHARGE RATE - Annual amount of rainfall that contributes to groundwater.

REDEVELOPMENT - New development activities on previously developed land.

RETENTION - The amount of precipitation on a drainage area that does not escape as runoff. It is the difference between total precipitation and total runoff.

REVERSE-SLOPE PIPE - A pipe which draws from below a permanent pool extending in a reverse angle up to the outlet control structure and which determines the water elevation of the permanent pool.

RIGHT-OF-WAY - Right of passage, as over another's property. A route that is lawful to use. A strip of land acquired for transport or utility construction.

RIPRAP - Broken rock, cobbles, or boulders placed on earth surfaces, such as the face of a dam or the bank of a stream, for protection against the action of water (waves); also applies to brush or pole mattresses, or brush and stone, or similar materials used for soil erosion control.

RISER - A type of outlet control structure that consists of a vertical pipe that extends from the bottom of a pond BMP and houses the control devices (weirs/orifices) to achieve the discharge rates for specified designs.

ROUGHNESS COEFFICIENT (HYDRAULICS) - A factor in velocity and discharge formulas representing the effect of channel roughness on energy losses in flowing water. Manning's "n" is a commonly used roughness coefficient.

RUNOFF (HYDRAULICS) - That portion of the precipitation on a drainage area that is discharged from the area in the stream channels. Types include surface runoff, ground water runoff or seepage.

RUNOFF COEFFICIENT ( $R_v$ ) - A value derived from a site impervious cover value that is applied to a given rainfall volume to yield a corresponding runoff volume.

**SAFETY BENCH** - A flat area above the permanent pool and surrounding a stormwater pond designed to provide a separation from the pond pool and adjacent slopes.

**SAND** - 1. (Agronomy) A soil particle between 0.05 and 2.0 millimeters in diameter. 2. A soil textural class. 3. (Engineering) According to the Unified Soil Classification System, a soil particle larger than the No. 200 sieve (0.074mm) and passing the No. 4 sieve (approximately 1/4 inch).

**SEDIMENT** - Solid material, both mineral and organic, that is in suspension, is being transported, or has been moved from its site of origin by air, water, gravity, or ice and has come to rest on the earth's surface either above or below sea level.

**SETBACKS** - The minimum distance requirements for location of a structural BMP in relation to roads, wells, septic fields, other structures.

**SHEET FLOW** - Water, usually storm runoff, flowing in a thin layer over the ground surface.

**SIDE SLOPES (ENGINEERING)** - The slope of the sides of a channel, dam or embankment. It is customary to name the horizontal distance first, as 1.5 to 1, or frequently, 1 ½: 1, meaning a horizontal distance of 1.5 feet to 1 foot vertical.

**SILT** - 1. (Agronomy) A soil separate consisting of particles between 0.05 and 0.002 millimeter in equivalent diameter. 2. A soil textural class. 3. (Engineering) According to the Unified Soil Classification System a fine-grained soil (more than 50 percent passing the No. 200 sieve) that has a low plasticity index in relation to the liquid limit.

**SOIL TEST** - Chemical analysis of soil to determine needs for fertilizers or amendments for species of plant being grown.

**SPILLWAY** - An open or closed channel, or both, used to convey excess water from a reservoir. It may contain gates, either manually or automatically controlled to regulate the discharge of excess water.

**STABILIZATION** - Providing adequate measures, vegetative and/or structural that will prevent erosion from occurring.

**STAGE (HYDRAULICS)** - The variable water surface or the water surface elevation above any chosen datum.

**STILLING BASIN** - An open structure or excavation at the foot of an outfall, conduit, chute, drop, or spillway to reduce the energy of the descending stream of water.

**STORMWATER FILTERING** - Stormwater treatment methods that utilize a constructed media to filter out pollutants entrained in urban runoff.

**STORMWATER PONDS** - A land depression or impoundment created for the detention or retention of stormwater runoff.

**STORMWATER WETLANDS** - Shallow, constructed pools that capture stormwater and allow for the growth of characteristic wetland vegetation.

**STREAM BUFFERS** - Zones of variable width that are located along both sides of a stream and are designed to provide a protective natural area along a stream corridor.

**STRUCTURAL BMPs** - Devices that are constructed to provide temporary storage and treatment of stormwater runoff.

SUBGRADE - The soil prepared and compacted to support a structure or a pavement system.

TECHNICAL RELEASE No. 20 (TR-20) - A Soil Conservation Service (now NRCS) watershed hydrology computer model that is used to compute runoff volumes and route storm events through a stream valley and/or ponds.

TECHNICAL RELEASE No. 55 (TR-55) - A watershed hydrology model developed by the Soil Conservation Service (now NRCS) used to calculate runoff volumes and provide a simplified routing for storm events through ponds.

TEMPORARY SEEDING - A seeding which is made to provide temporary cover for the soil while waiting for further construction or other activity to take place.

TEN-YEAR STORM - The 24-hour storm event which exceeds bankfull capacity and occurs on average once every ten years (or has a likelihood of occurrence of 1/10 in a given year).

TIME OF CONCENTRATION - Time required for water to flow from the most remote point of a watershed, in a hydraulic sense, to the outlet.

TOE (OF SLOPE) - Where the slope stops or levels out. Bottom of the slope.

“TOKEN” SPILLWAY - Those spillways placed above the water elevation of the largest managed storm, for emergencies only – not a spillway used to regulate flow from a managed storm.

TOPSOIL - Fertile or desirable soil material used to top dress road banks, subsoils, parent material, etc.

TOTAL SUSPENDED SOLIDS - The total amount of soils particulate matter that is suspended in the water column.

TRASH RACK - Grill, grate or other device at the intake of a channel, pipe, drain or spillway for the purpose of preventing oversized debris from entering the structure.

TWENTY-FIVE YEAR STORM - An extreme flood event which occurs on average once every 25 years or statistically has a 4% chance on average of occurring in a given year.

TWO-YEAR STORM - The 24-hour storm event which exceeds bankfull capacity and occurs on average once every two years (or has a likelihood of occurrence of 1/2 in a given year).

ULTRA-URBAN - Densely developed urban areas in which little pervious surface exists.

VOLUMETRIC RUNOFF COEFFICIENT ( $R_v$ ) - The value that is applied to a given rainfall volume to yield a corresponding runoff volume based on the percent impervious cover in a drainage basin.

WATER QUALITY VOLUME ( $WQ_v$ ) - The storage needed to capture and treat 90% of the average annual stormwater runoff volume for sites located within or discharging to high quality water and “hotspot” sites, and 80% of the runoff volume for sites located within or discharging to moderate quality water.

WATER SURFACE PROFILE - The longitudinal profile assumed by the surface of a stream flowing in an open channel; the hydraulic grade line.

WATERSHED INCHES - Watershed inches are used to compare stormwater volume requirements between sites of varying sizes. Required volumes in acre-feet can be converted to watershed inches by dividing by the total site area in acres and multiplying by 12 inches/feet.

WEDGES - Design feature in stormwater wetlands, which increases flow path length to provide for extended detention and treatment of runoff.

WET SWALE - An open drainage channel or depression, explicitly designed to retain water or intercept groundwater for water quality treatment.

WETTED PERIMETER - The length of the line of intersection of the plane or the hydraulic cross-section with the wetted surface of the channel.

WING WALL - Sidewall extensions of a structure used to prevent sloughing of banks or channels and to direct and confine overfall.



## *REFERENCES*

- Atlanta Regional Commission. August 2001. *Georgia Stormwater Management Manual*. Atlanta, GA. Available from [www.georgiastormwater.com](http://www.georgiastormwater.com).
- Bannerman, R. T., Owens, D. W. Dodds, R. B. and N. J. Hornewer. 1993. Sources of pollutants in Wisconsin stormwater. *Water Science and Technology* 28(3-5): 241-59.
- Barrett, Harris, & Associates. 1982. Draft report northern Guam lens study. Groundwater management program. Prepared for Government of Guam, Guam Environmental Protection Agency. Tamuning, Guam.
- Caltrans. 2003. Construction Site BMPs Manual, Stormwater Quality Handbook. Prepared for State of California Department of Transportation.
- Camp, Dresser, & Mckee, Inc. 1982. Final Report. Northern Guam lens study. Groundwater management program aquifer yield report. Prepared for Guam Environmental Protection Agency. Guam.
- City of Austin. 1988. Water Quality Management. In Environmental Criteria Manual. Environmental and Conservation Services. Austin, TX.
- Claytor, R. and T. Schueler. 1996. Design of Stormwater Filtering Systems. Center for Watershed Protection. Ellicott City, MD.
- CNMI. 1998. Water quality assessment 305(b) report. April 1, 1998.
- CNMI. 1998. Unified watershed assessment. September 1998.
- CNMI Water Quality Standards, Commonwealth Register Vol. 26, No. 9, September 24, 2004.
- CNMI and Guam Water Resources Board. 2000. Water Quality Standards.
- Duenas and Associates. 1996. Assessment of the applicability of specified urban runoff controls for new development on Guam. Prepared for Tetra Tech, Inc.
- Galli, F.J. 1990. Peat-sand filters: a proposed stormwater management practice for urban areas. Dept. of Environmental Programs. Metropolitan Washington Council of Governments. Washington, DC.

- GeoSyntec Consultants. 2005. Erosion and Sediment Control Manual. Prepared for Oregon Department of Environmental Quality. <http://www.deq.state.or.us/wq/wqpermit/ESCMannual.htm>.
- Guam Environmental Protection Agency. 2001 Revision. Guam water quality standards.
- Guam Environmental Protection Agency. 2004. 305b Report.
- Hollis, G. E. 1975. The effect of urbanization on floods of different recurrence interval. *Water Resources Research* 11(3):431-435.
- Horsley Witten Group. 2004. CNMI and Guam stormwater management criteria. Phase I final report. Prepared for the Commonwealth of the Northern Mariana Islands and the Territory of Guam
- Kundell, J. and T. Rasmussen. 1995. Recommendations of the Georgia Board of Regent's scientific panel on evaluating the erosion measurement standard defined by the Georgia erosion and sedimentation act. In *Proceedings of the 1995 Georgia Water Resources Conference*. Athens, Georgia.
- Lander, M.A. 2004. Rainfall climatology for Saipan: distribution, return-periods, El Nino, tropical cyclones, and long-term variations. Technical Report No. 103, Water and Environmental Research Institute of the Western Pacific, University of Guam. pp. 54.
- Leopold, L. B. 1994. *A View of a River*. Harvard University Press. Cambridge, MA.
- Maryland Department of the Environment. 1983. *Standards and Specifications for Infiltration. Sediment and Stormwater Administration*. 100 pp.
- New York State Soil and Water Conservation Committee. 2005. Guidelines for Urban Erosion and Sediment Control. <http://www.dec.state.ny.us/website/dow/toolbox/escstandards/>.
- NRCS. Soils Surveys for CNMI and Guam.
- Ogden Environmental, 2000. In *Georgia Stormwater Management Manual*. Atlanta, GA. Available from [www.georgiastormwater.com](http://www.georgiastormwater.com).
- Porter, V., T. Leberer, M. Gawel, J. Gutierrez, D. Burdick, V. Torres and E. Lujan. 2005. The state of the coral reef ecosystems of Guam. IN: *The state of the coral reef ecosystems of the United States and Pacific Freely Associated States: 2005*. NOAA Tech. Memorandum NOS NCCOS 11, pp.443-487.
- Prince George's County, 1999. *Low-Impact Development Design Strategies: An Integrated Design Approach*. Department of Environmental Resources, Programs and Planning Division, Prince George's County, Maryland.
- Schueler, T.R. 1987. *Controlling Urban Runoff: A Practical Manual for Planning and Designing Urban BMPs*, Department of Environmental Programs, Metropolitan Washington Council of Governments, Washington, DC.

- Schueler, T.R. 1994. The Importance of Imperviousness. *Watershed Protection Techniques*. 1(3): 100-111.
- Schueler, T.R. and H.K. Holland. 2000. The Practice of Watershed Protection: Techniques for protecting our nation's streams, lakes, rivers, and estuaries. Center for Watershed Protection, Ellicott City, MD.
- Starmer, J., Editor. 2005. The state of the coral reef ecosystems of the Commonwealth of the Northern Mariana Islands. IN: The state of the coral reef ecosystems of the United States and Pacific Freely Associated States: 2005. NOAA Tech. Memorandum NOS NCCOS 11, pp.399-441.
- Steuer, J., W. Selbig, N. Hornewer, and J. Prey. 1997. Sources of Contamination in an Urban Basin in Marquette, Michigan and an Analysis of Concentrations, Loads, and Data Quality. U.S. Geological Survey, Water-Resources Investigations Report 97-4242.
- Trimble, S. W. 1997. Contribution of stream channel erosion to sediment yield from an urbanizing watershed. *Science* 278:1442-1444.
- U.S. Army Corps of Engineers. 1980. Guam storm drainage manual. September 1980.
- USGS (Carruth). 2003. Ground-water resources of Saipan, Commonwealth of the Northern Mariana Islands.
- USGS (Hoffman, J.P., Carruth, R.L., Meyer, W.). 1998. Geology, Ground-Water Occurrence, and Estimated Well Yields from the Mariana Limestone, Kagman Area, Saipan, CNMI.
- USDA. 1986. TR-55 Urban Hydrology for Small Watersheds.
- USDA Soil Conservation Service. 1988. Soil survey of Territory of Guam. May 1988.
- USDA Soil Conservation Service. 1989. Soil survey of the Islands of Aguijan, Rota, Saipan, and Tinian, Commonwealth of the Northern Mariana Islands. July 1989.
- USEPA. 2005. National Menu of Best Management Practices for Stormwater Phase II. <http://cfpub.epa.gov/npdes/stormwater/menuofbmps/menu.cfm>.
- Vermont Agency of Natural Resources. April 2002. *The Vermont Stormwater Management Manual*. Waterbury, VT. Available from [www.vtwaterquality.org/stormwater.htm](http://www.vtwaterquality.org/stormwater.htm).
- Waschbusch *et al.* 2000. Sources of phosphorus in stormwater and street dirt from two urban residential basins in Madison, Wisconsin, 1994-1995. In: National Conference on Tools for Urban Water Resource Management and Protection. US EPA February 2000: pp. 15-55.

**<This page left blank intentionally>**



**Appendix A - Most Common Best Management Practices for Construction Sites**

- A1: Check Dam
- A2: Diversion Dike/Swale
- A3: Level Spreader
- A4: Perimeter Dike/Swale
- A5: Sediment Basin
- A6: Sediment Trap
- A7: Silt Fence
- A8: Stabilized Construction Entrance
- A9: Storm Drainage Inlet Protection
- A10: Turbidity Curtain
- A11: Vegetated and Lined Waterways
- A12: Rock Outlet Protection
- A13: Erosion Control Blankets
- A14: Stabilization with Vegetation, Mulch, or Topsoil

**<This page left blank intentionally>**

## **A1: Check Dam**

### **Definition**

Small barriers or dams constructed of stone, bagged sand or gravel, or other durable material across a drainage way.

### **Purpose**

To reduce erosion in a drainage channel by restricting the velocity of flow in the channel.

### **Condition Where Practice Applies**

This practice is used as a temporary or emergency measure to limit erosion by reducing velocities in small open channels that are degrading or subject to erosion and where permanent stabilization is impractical due to short period of usefulness and time constraints of construction.

### **Design Guidance**

**Drainage Area:** Maximum drainage area above the check dam shall not exceed two (2) acres.

**Height:** Not greater than 2 feet. Center shall be maintained 9 inches lower than abutments at natural ground elevation.

**Side Slopes:** Shall be 2:1 or flatter.

**Spacing:** The check dams shall be spaced as necessary in the channel so that the crest of the downstream dam is at the elevation of the toe of the upstream dam. This spacing is equal to the height of the check dam divided by the channel slope.

$$S = h/s$$

Where:

S = spacing interval (ft.)

h = height of check dam (ft.)

s = channel slope (ft./ft.)

**Stone size:** Use a well-graded stone matrix 2 to 9 inches in size.

The overflow of the check dams will be stabilized to resist erosion that might be caused by the check dam.

Check dams should be anchored in the channel by a cutoff trench 1.5 ft. wide and 0.5 ft. deep and lined with filter fabric to prevent soil migration.

### **Maintenance**

The check dams should be inspected after each runoff event. Correct all damage immediately. If significant erosion has occurred between structures, a liner of stone or other suitable material should be installed in that portion of the channel. Remove sediment accumulated behind the dam as needed to allow channel to drain through the stone check dam and prevent large flows from carrying sediment over the dam. Replace stones as needed to maintain the design cross section of the structures.

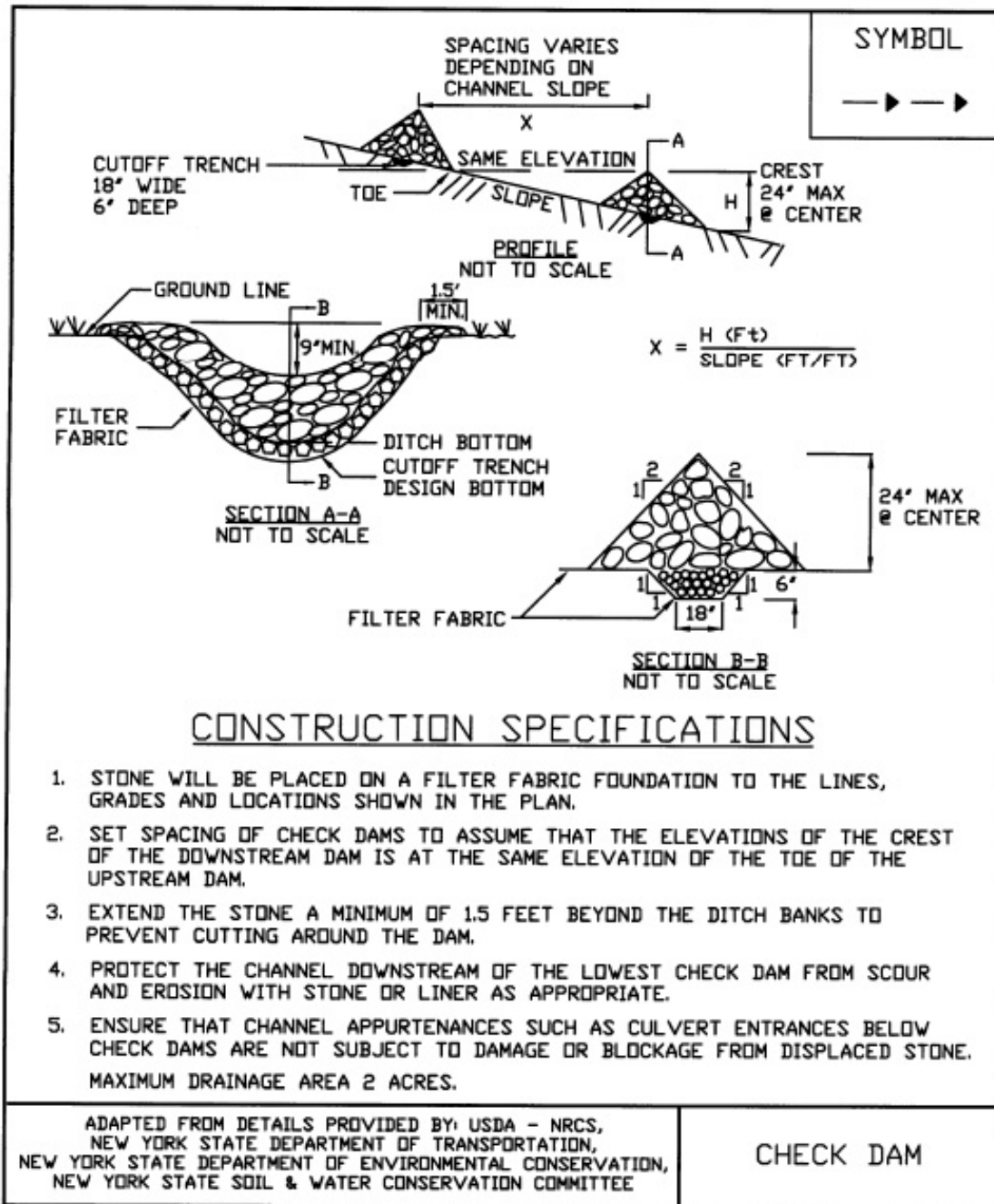

Figure A1.1 Check Dam

## **A2: Diversion Dike/Swale**

### **Definition**

A temporary diversion swale is a temporary excavated drainage way to divert flow. A temporary diversion dike is a berm or ridge of compacted soil, located in such a manner as to channel water to a desired location.

### **Purpose**

The purpose of a temporary diversion swale is to prevent runoff from entering disturbed areas by intercepting and diverting it to a stabilized outlet or to intercept sediment laden water and divert it to a sediment trapping device.

The purpose of a diversion earth dike is to direct runoff to a sediment trapping device, thereby reducing the potential for erosion and off site sedimentation. Earth dikes can also be used for diverting clean water away from disturbed areas.

### **Conditions Where Practice Applies**

Temporary diversion swales are constructed:

1. to divert flows from entering a disturbed area.
2. intermittently across disturbed areas to shorten overland flow distances.
3. to direct sediment laden water along the base of slopes to a trapping device.
4. to transport offsite flows across disturbed areas such as rights-of-way.

Swales collecting runoff from disturbed areas shall remain in place until the disturbed areas are permanently stabilized.

Earth dikes are often constructed across disturbed areas and around construction sites such as graded parking lots and subdivisions. The dikes shall remain in place until the disturbed areas are permanently stabilized.

### **Design Guidance for Temporary Diversion Swales**

See **Figure A2.1** details.

<b>General</b>	<b>Swale A</b>	<b>Swale B</b>
Drainage Area	<5 Ac	5-10 Ac
Bottom Width of		
Flow Channel	4 ft	6 ft
Depth of Flow Channel	1 ft	1 ft
Side Slopes	2:1 or flatter	2:1 or flatter
Grade	0.5% Min. 20% Max.	0.5% Min. 20% Max.

For drainage areas larger than 10 acres, refer to the Specification for Waterways.

**Stabilization** - Stabilization of the swale shall be completed within 7 days of installation in accordance with the appropriate standard and specifications for vegetative stabilization or stabilization with mulch as determined by the time of year.

**Outlet** - Swale shall have an outlet that functions with a minimum of erosion, and dissipates runoff velocity prior to discharge off the site. Runoff shall be conveyed to a sediment trapping device such as a sediment trap or sediment basin until the drainage area above the swale is adequately stabilized. The on-site location may need to be adjusted to meet field conditions in order to utilize the most suitable outlet condition. If a swale is used to divert clean water flows from entering a disturbed area, a sediment trapping device may not be needed.

### Design Guidance for Dikes

See **Figure A2.2** for details.

<b>General</b>	<b>Dike A</b>	<b>Dike B</b>
Drainage Area	<5 Ac	5-10 Ac
Dike Height	18 in.	36 in.
Dike Width	24 in.	36 in.
Flow Width	4 ft.	6 ft.
Flow Depth in Channel	8 in.	15 in.
Side Slopes	2:1 or flatter	2:1 or flatter
Grade	0.5% Min. 20% Max.	0.5% Min. 20% Max.

For drainage areas larger than 10 acres, refer to the Standard and Specifications for Waterways.

**Stabilization** - Stabilization of the dike shall be completed within 7 days of installation.

**Outlet** - Earth dikes shall have an outlet that functions with a minimum of erosion. Runoff shall be conveyed to a sediment trapping device until the drainage area above the dike is adequately stabilized. The on-site location may need to be adjusted to meet field conditions in order to utilize the most suitable outlet.

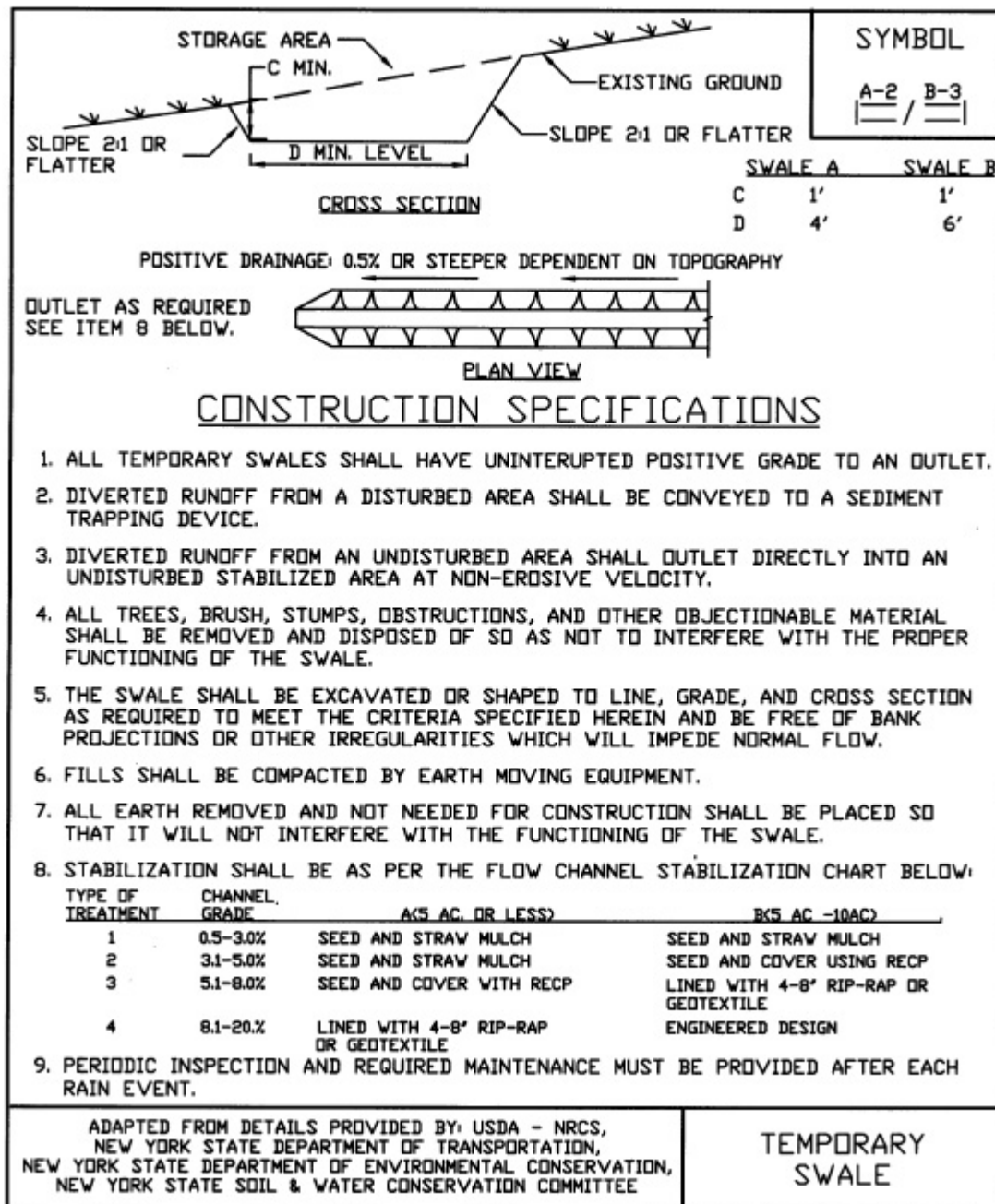

Figure A2.1 Diversion (Temporary) Swale

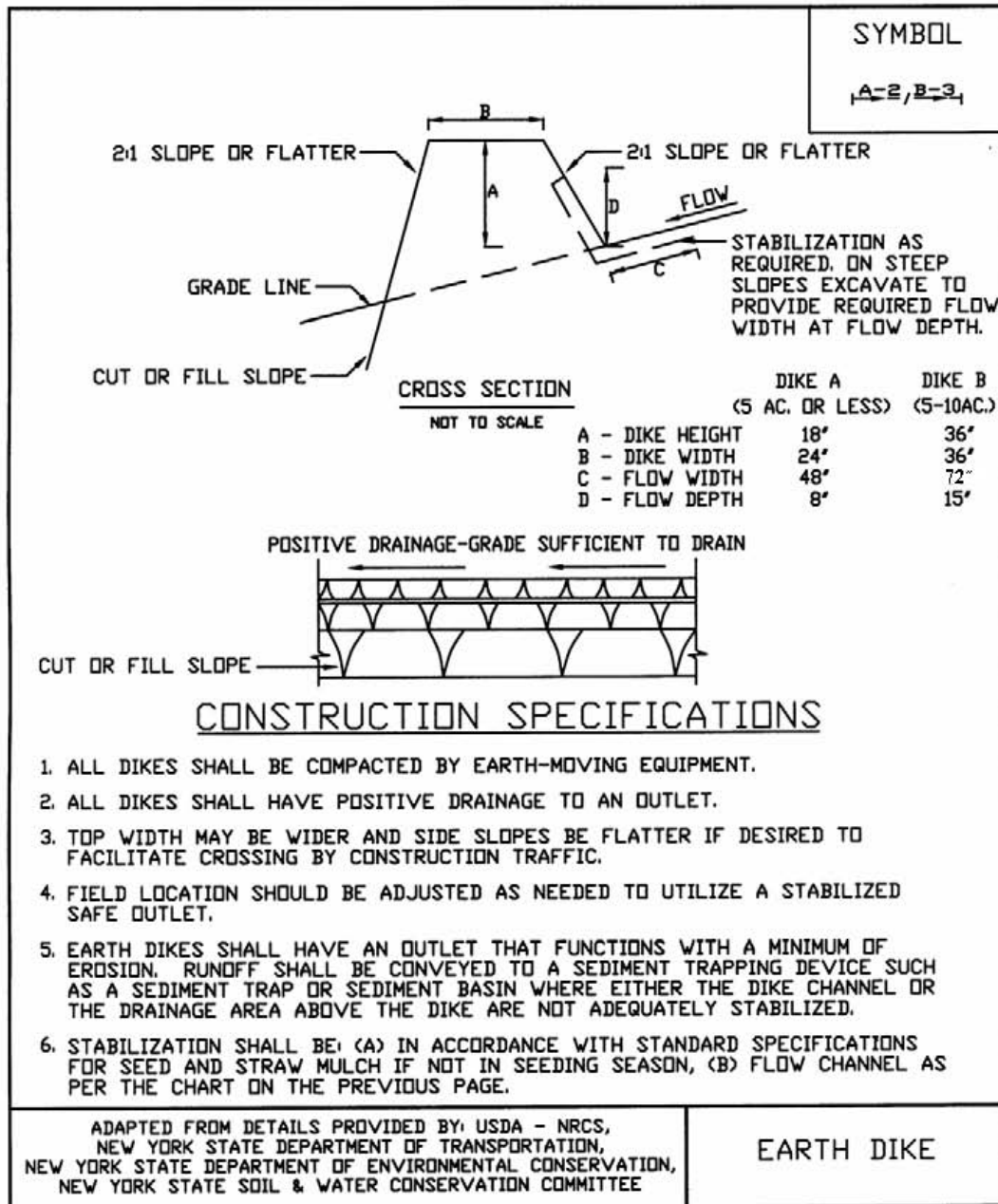

Figure A2.2 Earth Dike



### **A3: Level Spreader**

#### **Definition**

A temporary non-erosive outlet for concentrated runoff constructed to disperse flow uniformly across a slope.

#### **Purpose**

To convert concentrated flow to sheet flow and release it uniformly over a stabilized area.

#### **Conditions Where Practice Applies**

Where sediment-free storm runoff can be released in sheet flow down a stabilized slope without causing erosion; where a level lip can be constructed without filling; where the area below the level lip is uniform with a slope of 10% or less and the runoff will not re-concentrate after release; and where no traffic will be allowed over spreader.

#### **Design Guidance**

The design capacity shall be determined by estimating the peak flow from the design storm. The drainage area shall be restricted to limit the maximum flows into the spreader to 30 cfs. The level spreader shall have the following minimum dimension:

Design Flow (cfs)	Minimum Entrance Width (ft)	Depth (ft)	End Width (ft)	Length (ft)
0-10	10	0.5	3	10
10-20	16	0.6	3	20
20-30	24	0.7	3	30

A transition section 20 feet in length shall be constructed from the width of the diversion or channel to the width of the spreader to ensure uniform outflow. This last transition section will blend the diversion grade to zero grade at the beginning of the spreader.

Construct the level lip in undisturbed soil to a uniform height and zero grade over the length of the spreader. Protect the lip with an erosion-resistant material or mat to prevent erosion and allow vegetation to become established. The outlet area should be a generally smooth, well vegetated areas no steeper than 10 percent.

See **Figure A3.1** for details.

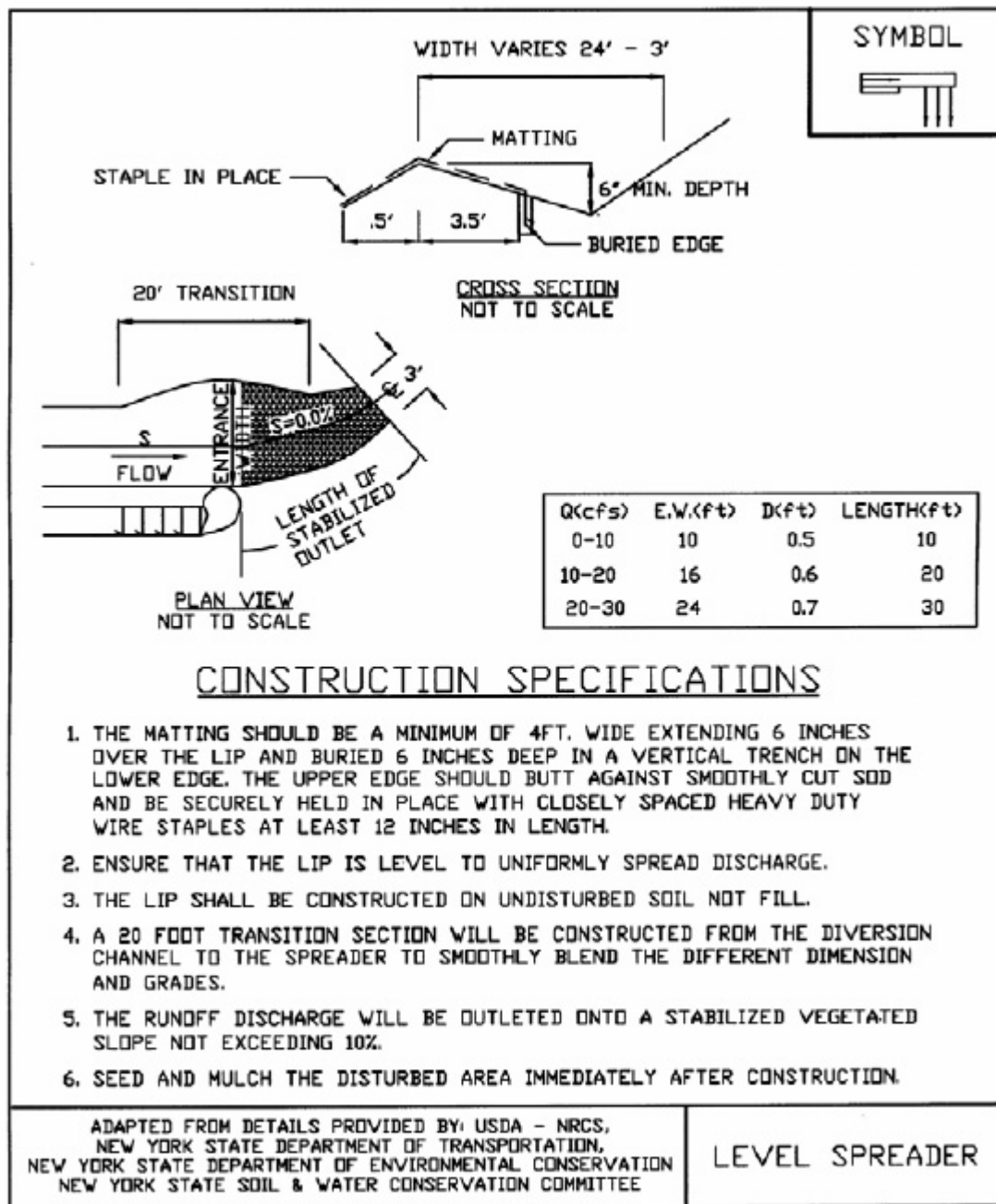

Figure A3.1 Level Spreader

## **A4: Perimeter Dike/Swale**

### **Definition**

A temporary ridge of soil excavated from an adjoining swale located along the perimeter of the site or disturbed area.

### **Purpose**

The purpose of a perimeter dike/swale is to prevent off site storm runoff from entering a disturbed area and to prevent sediment laden storm runoff from leaving the construction site or disturbed area.

### **Conditions Where Practice Applies**

Perimeter dike/swale is constructed to divert flows from entering a disturbed area, or along tops of slopes to prevent flows from eroding the slope, or along base of slopes to direct sediment laden flows to a trapping device. The perimeter dike/swale shall remain in place until the disturbed areas are permanently stabilized.

### **Design Guidance**

See **Figure A4.1** for details.

The perimeter dike/swale shall not be constructed outside the property lines without obtaining legal easements from affected adjacent property owners. A design is not required for perimeter dike/swale. The following criteria shall be used:

**Drainage area** – Less than 2 acres (for drainage areas larger than 2 acres but less than 10 acres, see earth dike or temporary swale; for drainage areas larger than 10 acres, see standard and specifications for waterways).

**Height** – 18 inches minimum from bottom of swale to top of dike evenly divided between dike height and swale depth.

**Bottom width of dike** – 2 feet minimum.

**Width of swale** – 2 feet minimum.

**Grade** – Dependent upon topography, but shall have positive drainage (sufficient grade to drain) to an adequate outlet. Maximum allowable grade not to exceed 8 percent.

**Stabilization** – The disturbed area of the dike and swale shall be stabilized within 7 days of installation, in accordance with the standard and specifications for temporary swales.

### **Outlet**

1. Perimeter dike/swale shall have a stabilized outlet.
2. Diverted runoff from a protected or stabilized upland area shall outlet directly onto an undisturbed stabilized area.
3. Diverted runoff from a disturbed or exposed upland area shall be conveyed to a sediment trapping device such as a sediment trap, sediment basin, or to an area protected by any of these practices.
4. The on-site location may need to be adjusted to meet field conditions in order to utilize the most suitable outlet.

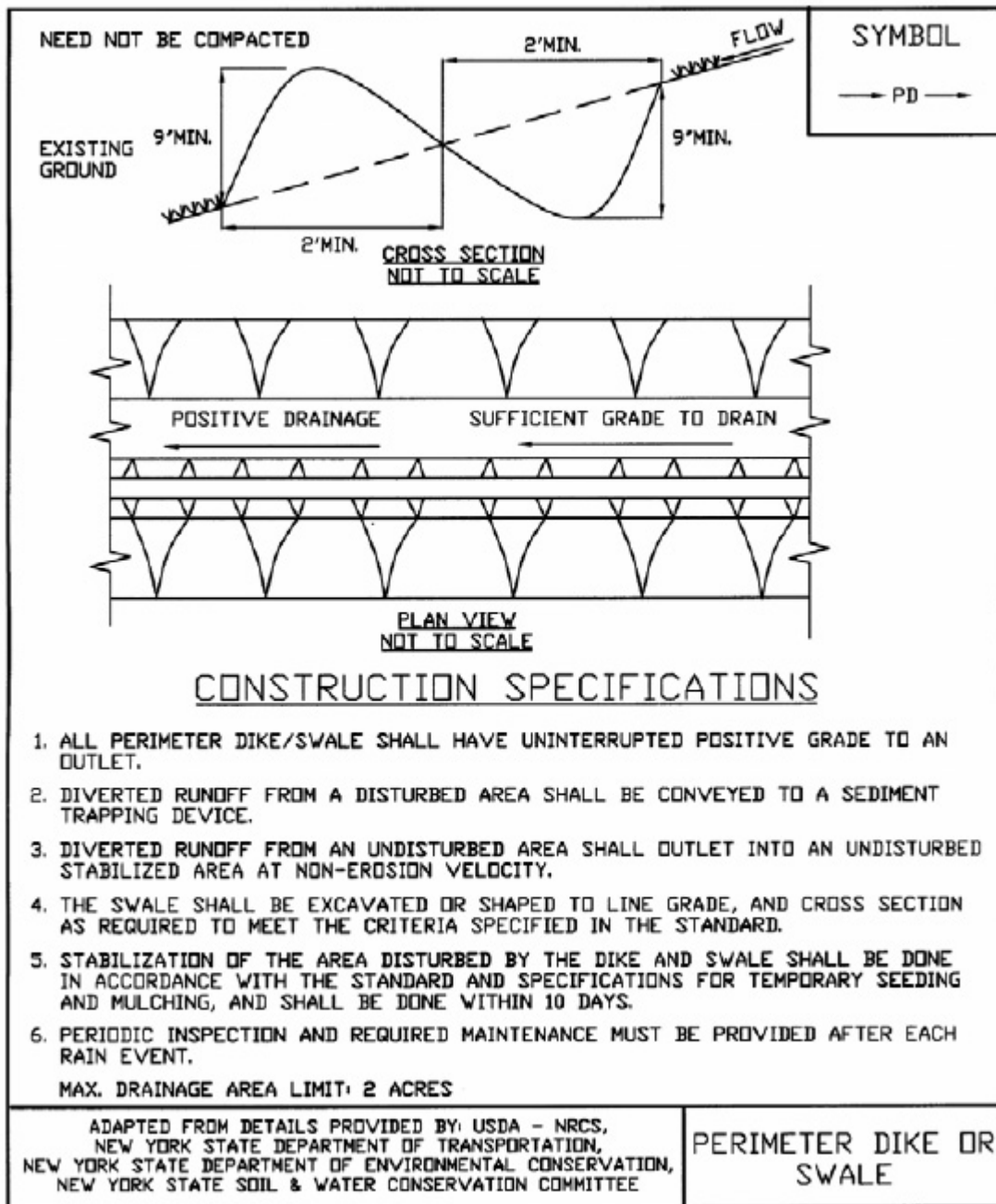

Figure A4.1 Perimeter Dike/Swale

## **A5: Sediment Basin**

### **Definition**

A temporary barrier or dam constructed across a drainage way or at other suitable locations to intercept sediment laden runoff and to trap and retain the sediment.

### **Scope**

This standard applies to the installation of temporary sediment basins on sites where: (a) failure of the structure would not result in loss of life, damage to homes or buildings, or interruption of use or service of public roads or utilities; (b) the drainage area does not exceed 100 acres; and (c) the basin is to be removed within 36 months after the beginning of construction of the basin. Permanent (to function more than 36 months) sediment basins, or temporary basins exceeding the classification requirements for class 1 and 2, or structures that temporarily function as a sediment basin but are intended for use as a permanent pool shall be classified as permanent structures and shall conform to criteria appropriate for permanent structures. These structures shall be designed and constructed to conform to NRCS Standard and Specification No. 378 for Ponds in the National Handbook of Conservation Practices. The total volume of permanent sediment basins shall be equal to or exceed the capacity requirements for temporary basins contained herein.

### **Classification of Temporary Sediment Basins**

For the purpose of this standard, temporary sediment basins are classified as follows:

Class	1	2
Max. Drainage Area (acres)	100	100
Max. Height <sup>1</sup> of Dam (ft.)	10	15
Min. Embankment Top Width	8	10
Embankment Side Slopes	2:1 or Flatter	2 ½:1 or Flatter
Anti-Seep Control Required	Yes	Yes

1- Height is measured from the low point of original ground at the downstream toe of the dam to the top of the dam.

### **Purpose**

The purpose of a sediment basin is to intercept sediment laden runoff and reduce the amount of sediment leaving the disturbed area in order to protect drainage ways, properties, and rights-of-way below the sediment basin.

### **Conditions Where Practice Applies**

A sediment basin is appropriate where physical site conditions or land ownership restrictions preclude the installation of other erosion control measures to adequately control runoff, erosion, and sedimentation. However, it is strongly encouraged to use a basin in addition to other ESC

measures if practicable. It may be used below construction operations which expose critical areas to soil erosion. The basin shall be maintained until the disturbed area is protected against erosion by permanent stabilization.

## Design Guidance

**Compliance with Laws and Regulations** - Design and construction shall comply with local laws, ordinances, rules and regulations, including permits.

**Location** - The sediment basin should be located to obtain the maximum storage benefit from the terrain and for ease of cleanout of the trapped sediment. It should be located to minimize interference with construction activities and construction of utilities. Whenever possible, sediment basins should be located so that storm drains may outfall or be diverted into the basin.

**Size and Shape of the Basin** - The minimum sediment storage volume of the basin, as measured from the bottom of the basin to the elevation of the crest of the principal spillway shall be at least 5,500 cubic feet per acre draining to the basin. This 5,500 cubic feet is equivalent to 1.5 inches of precipitation (treatment criteria **Section 2.1.2**) per acre of drainage area. The entire drainage area is used for this computation, rather than the disturbed area above, to maximize trapping efficiency. The length to width ratio shall be greater than 2:1, where length is the distance between the inlet and outlet. A wedge shape shall be used with the inlet located at the narrow end.

## Surface Area

$A = 0.01 Q_p$  or,  $A = 0.015 \times D.A.$  (whichever is greater), where

A = the basin surface area, acres, measured at the service spillway crest; and

$Q_p$  = the peak inflow rate, cfs, for the design storm.

D.A. = contributing drainage area in acres. One half of the design sediment storage volume (67 cubic yards per acre drainage area) shall be in the form of a permanent pool, and the remaining half as drawdown volume.

Sediment basins shall be cleaned out when the permanent pool volume remaining as described above is reduced by 50 percent, except in no case shall the sediment level be permitted to build up higher than one foot below the principal spillway crest. At this elevation, cleanout shall be performed to restore the original design volume to the sediment basin. The elevation corresponding to the maximum allowable sediment level shall be determined and shall be stated in the design data as a distance below the top of the riser and shall be clearly marked on the riser. The basin dimensions necessary to obtain the required basin volume as stated above shall be clearly shown on the plans to facilitate plan review, construction, and inspection.

## Spillway Design

Runoff shall be computed by the method outlined in: Chapter 2, Estimating Runoff, Engineering Field Handbook available in the Natural Resources Conservation Service offices or, by TR-55, Urban Hydrology for Small Watersheds. Runoff computations shall be based upon the worst soil cover conditions expected to prevail in the contributing drainage area during the anticipated effective life of the structure.

*A. Capacity:* The minimum capacity of the emergency spillway shall be that required to pass the peak rate of runoff from the 10-year design storm, less any reduction due to flow in the pipe spillway.

*B. Velocities:* The velocity of flow in the exit channel shall not exceed 5 feet per second for vegetated channels. For channels with erosion protection other than vegetation, velocities shall be within the non-erosive range for the type of protection used.

*C. Erosion Protection:* Erosion protection shall be provided for by vegetation as prescribed in this publication or by other suitable means such as riprap, asphalt or concrete.

*D. Freeboard:* Freeboard is the difference between the design high water elevation in the emergency spillway and the top of the settled embankment. If there is no emergency spillway, it is the difference between the water surface elevation required to pass the design flow through the pipe and the top of the settled embankment. Freeboard shall be at least one foot.

### ***Embankment Cross-Section***

- Class 1 Basins: The minimum top width shall be eight feet. The side slopes shall not be steeper than 2:1.
- Class 2 Basins: The minimum top width shall be ten feet. The side slopes shall not be steeper than 2.5:1.

***Entrance of Runoff into Basin*** - Points of entrance of surface runoff into excavated sediment basins shall be protected to prevent erosion. Considerable care should be given to the major points of inflow into basins. In many cases the difference in elevation of the inflow and the bottom of the basin is considerable, thus creating a potential for sever gullyng and sediment generation. Often a riprap drop at major points of inflow would eliminate gullyng and sediment generation. Diversions, grade stabilization structures or other water control devices shall be installed as necessary to ensure direction of runoff and protect points of entry into the basin. Points of entry should be located so as to ensure maximum travel distance of entering runoff to point of exit (the riser) from the basin.

***Disposal*** - The sediment basin plans shall indicate the method(s) of disposing of the sediment removed from the basin. The sediment shall be placed in such a manner that it will not erode from the site. The sediment shall not be deposited downstream from the basin, adjacent to a stream or floodplain. Disposal sites will be covered by an approved sediment control plan. The sediment basis plans shall also show the method of disposing of the sediment basin after the drainage area is stabilized, and shall include the stabilization of the sediment basin site. Water contained within the storage areas shall be removed from the basin by pumping, cutting the top of the riser, or other appropriate method prior to removing or breaching the embankment. Sediment shall not be allowed to flush into a stream or drainage way.

***Safety*** - Local ordinances and regulations must be adhered to regarding health and safety.

### **Construction Specifications**

***Site Preparation*** - Areas under the embankment shall be cleared, grubbed, and stripped of topsoil to remove trees, vegetation, roots, or other objectionable material. In order to facilitate

cleanout and restoration, the pool area (measured at the top of the pipe spillway) will be cleared of all brush, trees, and other objectionable materials.

**Cutoff-Trench** - A cutoff trench shall be excavated along the centerline of earth fill embankments. The minimum depth shall be two feet. The cutoff trench shall extend up both abutments to the riser crest elevation. The minimum bottom width shall be four feet, but wide enough to permit operation of excavation and compaction equipment. The side slopes shall be no steeper than 1:1. Compaction requirements shall be the same as those for embankment. The trench shall be dewatered during the back-filling/compaction operations.

**Embankment** - The fill material shall be taken from approved areas shown on the plans. It shall be clean mineral soil free of roots, woody vegetation, oversized stones, rocks, or other objectionable material. Relatively pervious materials such as sand or gravel shall not be placed in the embankment. Areas on which fill is to be placed shall be scarified prior to placement of fill. The fill material shall contain sufficient moisture so that it can be formed by hand into a ball without crumbling. If water can be squeezed out of a ball, it is too wet for proper compaction. Fill material shall be placed in six to eight inch thick continuous layers over the entire length of the fill. Compaction shall be obtained by routing and hauling the construction equipment over the fill so that the entire surface of each layer of the fill is traversed by at least one wheel or tread track of the equipment or by the use of a compactor. The embankment shall be constructed to an elevation 10 percent higher than the design height to allow for settlement.

**Pipe Spillway** - The riser shall be securely attached to the barrel or barrel stub by welding the full circumference making a watertight structural connection. The barrel stub must be attached to the riser at the same percent (angle) of grade as the outlet conduit. The connection between the riser and the riser base shall be watertight. All connections between barrel sections must be achieved by approved watertight bank assemblies. The barrel and riser shall be placed on a firm, smooth foundation of impervious soil. Pervious materials such as sand, gravel, or crushed stone shall not be used as backfill around the pipe or anti-seep collars. The fill material around the pipe spillway shall be placed in four inch layers and compacted under and around the pipe to at least the same density as the adjacent embankment. A minimum depth of two feet of hand compacted backfill shall be placed over the pipe spillway before crossing it with construction equipment. Steel base plates on risers shall have at least 2 ½ feet of compacted earth, stone, or gravel placed over it to prevent flotation.

**Emergency Spillway** - The emergency spillway shall be installed in undisturbed ground. The achievement of planned elevations, grades, design width, entrance and exit channel slopes are critical to the successful operation of the emergency spillway and must be constructed within a tolerance of +/- 0.2 feet.

**Vegetative Treatment** - Stabilize the embankment and emergency spillway in accordance with the appropriate vegetative standard and specification immediately following construction. In no case shall the embankment remain unstabilized for more than seven (7) days.

**Erosion and Pollution Control** - Construction operations shall be carried out in such a manner that erosion and water pollution will be minimized. Local laws shall be complied with concerning pollution abatement.



**Safety** - All local requirements shall be met concerning fencing and signs, warning the public of hazards of soft sediment and floodwater.

### **Maintenance**

1. Repair all damages caused by soil erosion and construction equipment at or before the end of each working day.
2. Sediment shall be removed from the basin when it reaches the specified distance below the top of the riser (shall not exceed 50 percent capacity). This sediment shall be placed in such a manner that it will not erode from the site. The sediment shall not be deposited downstream from the embankment, adjacent to a stream or floodplain.

### **Final Disposal**

When temporary structures have served their intended purpose and the contributing drainage area has been properly stabilized, the embankment and resulting sediment deposits are to be leveled or otherwise disposed of in accordance with the approved sediment control plan. The proposed use of a sediment basin site will often dictate final disposition of the basin and any sediment contained therein. If the site is scheduled for future construction, then the basin material and trapped sediments must be removed, safely disposed of, and backfilled with a structural fill. When the basin area is to remain open space, the pond may be pumped dry, graded, and back filled.

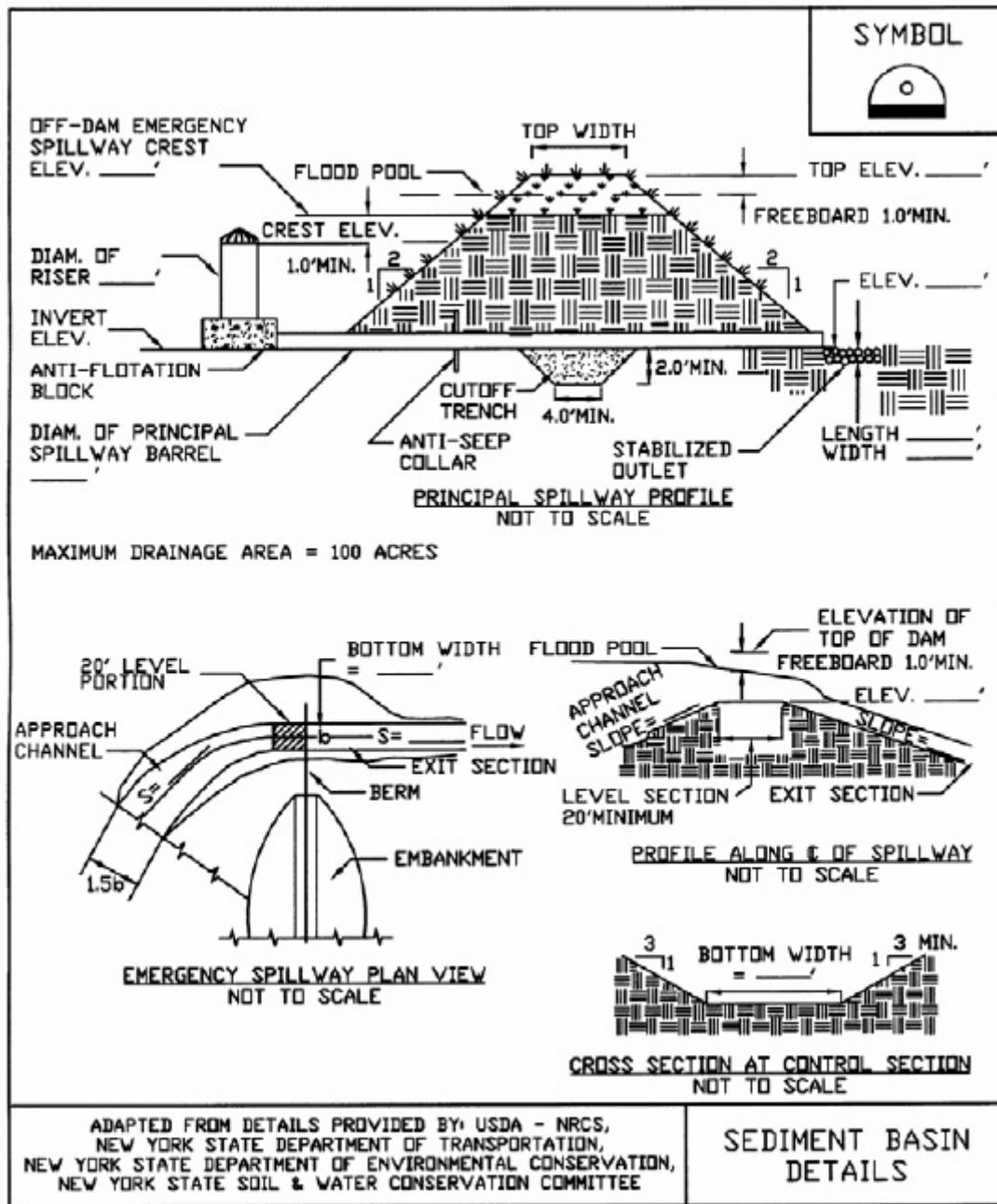
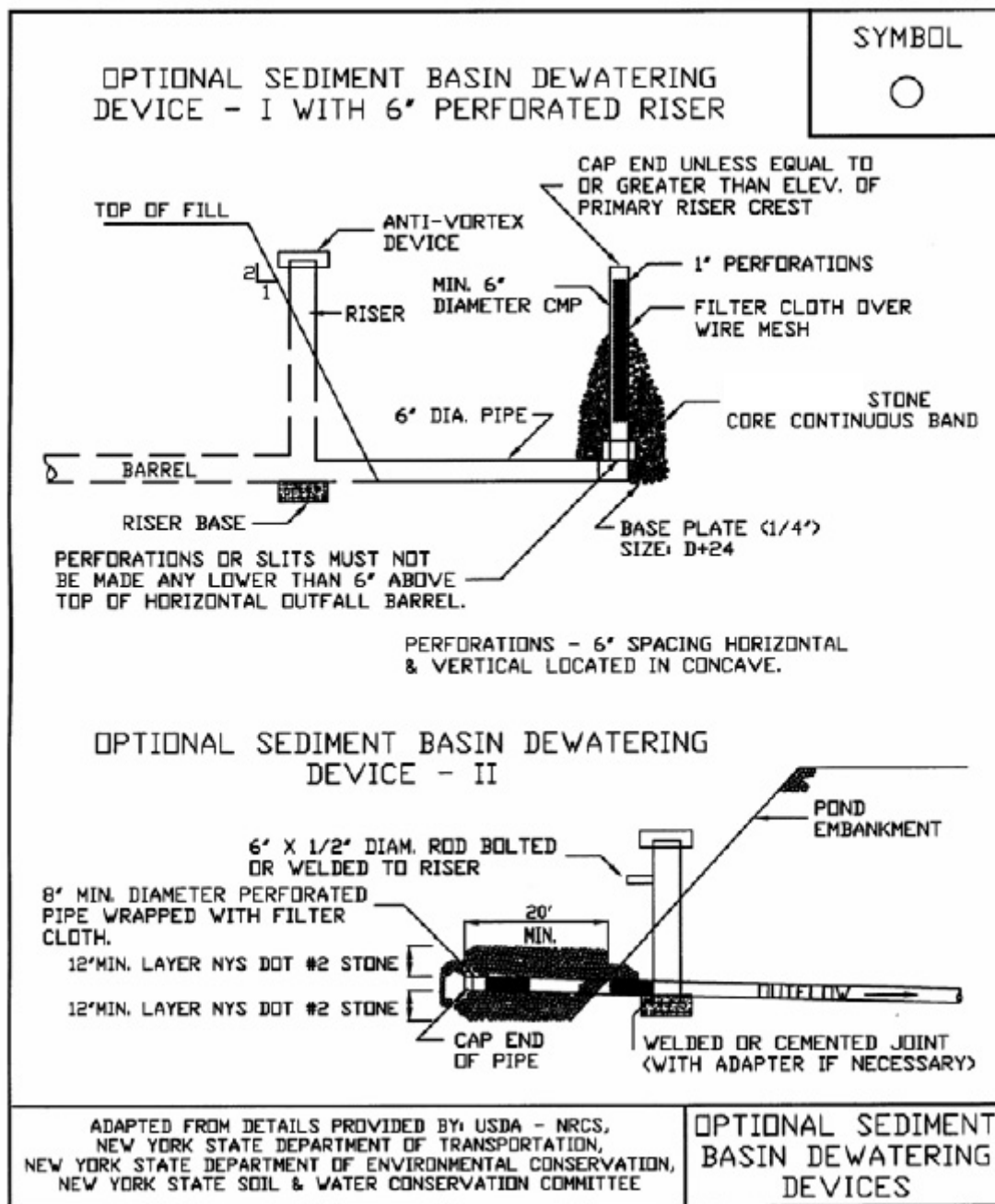

Figure A5.1 Sediment Basin



**Figure A5.2 Optional Sediment Basin Dewatering Devices**

## **A6: Sediment Trap**

### **Definition**

A temporary sediment control device formed by excavation and/or embankment to intercept sediment laden runoff and retain the sediment.

### **Purpose**

The purpose of the structure is to intercept sediment-laden runoff and trap the sediment in order to protect drainage ways, properties, and rights-of-way below the sediment trap from sedimentation.

### **Conditions Where Practice Applies**

A sediment trap is usually installed in a drainage way, at a storm drain inlet, or other points of collection from a disturbed area. Sediment traps should be used to artificially break up the natural drainage area into smaller sections where a larger device (sediment basin) would be less effective.

### **Design Guidance**

If any of the design criteria presented here cannot be met, see Standard and Specification for Sediment Basin.

**Drainage Area** - The drainage area for sediment traps shall be in accordance with the specific type of sediment trap used (Type I through III).

**Location** - Sediment traps shall be located so that they can be installed prior to grading or filling in the drainage area they are to protect. Traps must not be located any closer than 20 feet from a proposed building foundation if the trap is to function during building construction. Locate traps to obtain maximum storage benefit from the terrain and for ease of cleanout and disposal of the trapped sediment.

**Trap Size** - The volume of a sediment trap as measured at the elevation of the crest of the outlet shall be at least 5,500 cubic feet per acre of drainage area. The volume of a constructed trap shall be calculated using standard mathematical procedures. The volume of a natural sediment trap may be approximated by the equation:  $\text{Volume (cu.ft.)} = 0.4 \times \text{surface area (sq.ft.)} \times \text{maximum depth (ft.)}$ .

**Trap Cleanout** - Sediment shall be removed and the trap restored to the original dimensions when the sediment has accumulated to  $\frac{1}{2}$  of the design depth of the trap. Sediment removed from the trap shall be deposited in a protected area and in such a manner that it will not erode.

**Embankment** - All embankments for sediment traps shall not exceed five (5) feet in height as measured at the low point of the original ground along the centerline of the embankment. Embankments shall have a minimum four (4) foot wide top and side slopes of 2:1 or flatter. The embankment shall be compacted by traversing with equipment while it is being constructed. The embankment shall be stabilized with seed and mulch as soon as it is completed. The elevation of the top of any dike directing water to any sediment trap will equal or exceed the maximum height of the outlet structure along the entire length of the trap.

**Excavation** - All excavation operations shall be carried out in such a manner that erosion and water pollution shall be minimal. Excavated portions of sediment traps shall have 1:1 or flatter slopes.

**Outlet** - The outlet shall be designed, constructed, and maintained in such a manner that sediment does not leave the trap and that erosion at or below the outlet does not occur. Sediment

traps must outlet onto stabilized (preferable undisturbed) ground, into a watercourse, stabilized channel, or into a storm drain system. Distance between inlet and outlet should be maximized to the longest length practicable.

### **Types of Sediment Traps**

There are five (5) specific types of sediment traps which vary according to their function, location, or drainage area.

- I. Pipe Outlet Sediment Trap
- II. Grass Outlet Sediment Trap
- III. Stone Outlet Sediment Trap

#### **I. Pipe Outlet Sediment Trap**

A Pipe Outlet Sediment Trap consists of a trap formed by embankment or excavation. The outlet for the trap is through a perforated riser and a pipe through the embankment. The outlet pipe and riser shall be made of steel, corrugated metal or other suitable material. The top of the embankment shall be at least 1 ½ feet above the crest of the riser. The top 2/3 of the riser shall be perforated with one (1) inch nominal diameter holes or slits spaced six (6) inches vertically and horizontally placed in the concave portion of the corrugated pipe. No holes or slits will be allowed within six (6) inches of the top of the horizontal barrel. All pipe connections shall be watertight. The riser shall be wrapped with ½ to ¼ inch hardware cloth wire then wrapped with filter cloth with a sieve size between #40-80 and secured with strapping or connecting band at the top and bottom of the cloth. The cloth shall cover an area at least six (6) inches above the highest hole and six (6) inches below the lowest hole. The top of the riser pipe shall not be covered with filter cloth.

The riser shall have a base with sufficient weight to prevent flotation of the riser. Two approved bases are:

1. A concrete base 12 in. thick with the riser embedded 9 in. into the concrete base, or
2. One quarter inch, minimum, thick steel plate attached to the riser by a continuous weld around the circumference of the riser to form a watertight connection. The plate shall have 2.5 feet of stone, gravel, or earth placed on it to prevent flotation. In either case, each side of the square base measurement shall be the riser diameter plus 24 inches.

Pipe outlet sediment traps shall be limited to a five (5) acre maximum drainage area. Pipe outlet sediment traps may be interchangeable in the field with stone outlet or riprap sediment traps provided that these sediment traps are constructed in accordance with the detail and specifications for that trap.

#### **II. Grass Outlet Sediment Trap**

A Grass Outlet Sediment Trap consists of a trap formed by excavating the earth to create a holding area. The trap has a discharge point over natural existing grass. The outlet crest width (feet) shall be equal to four (4) times the drainage area (acres) with a minimum width of four (4) feet. The outlet shall be free of any restrictions to flow. The outlet lip must remain undisturbed and level. The volume of this trap shall be computed at the elevation of the crest of the outlet. Grass outlet sediment traps shall be limited to a five (5) acre maximum drainage area.

Select Pipe Diameter from the Following Table:

<u>Barrel Diameter (in.)</u>	<u>Riser Diameter (in.)</u>	<u>Maximum Drainage Area (ac.)</u>
12	15	1
15	18	2
18	21	3
21	24	4
21	27	5

### **III. Stone Outlet Sediment Trap**

A Stone Outlet Sediment Trap consists of a trap formed by an embankment or excavation. The outlet of this trap is over a stone section placed on level ground. The minimum length (feet) of the outlet shall be equal to four (4) times the drainage area (acres). Required storage shall be 5,500 cubic feet per acre of drainage area. The outlet crest (top of stone in weir section) shall be level, at least one (1) foot below top of embankment and no more than one (1) foot above ground beneath the outlet. Stone used in the outlet shall be small riprap (4 in. x 8 in.). To provide more efficient trapping effect, a layer of filter cloth should be embedded one (1) foot back into the upstream face of the outlet stone or a one (1) foot thick layer of two (2) inch or finer aggregate shall be placed on the upstream face of the outlet. Stone Outlet Sediment Traps may be interchangeable in the field with pipe or riprap outlet sediment traps provided they are constructed in accordance with the detail and specifications for those traps. Stone outlet sediment traps shall be limited to a five (5) acre maximum drainage area.

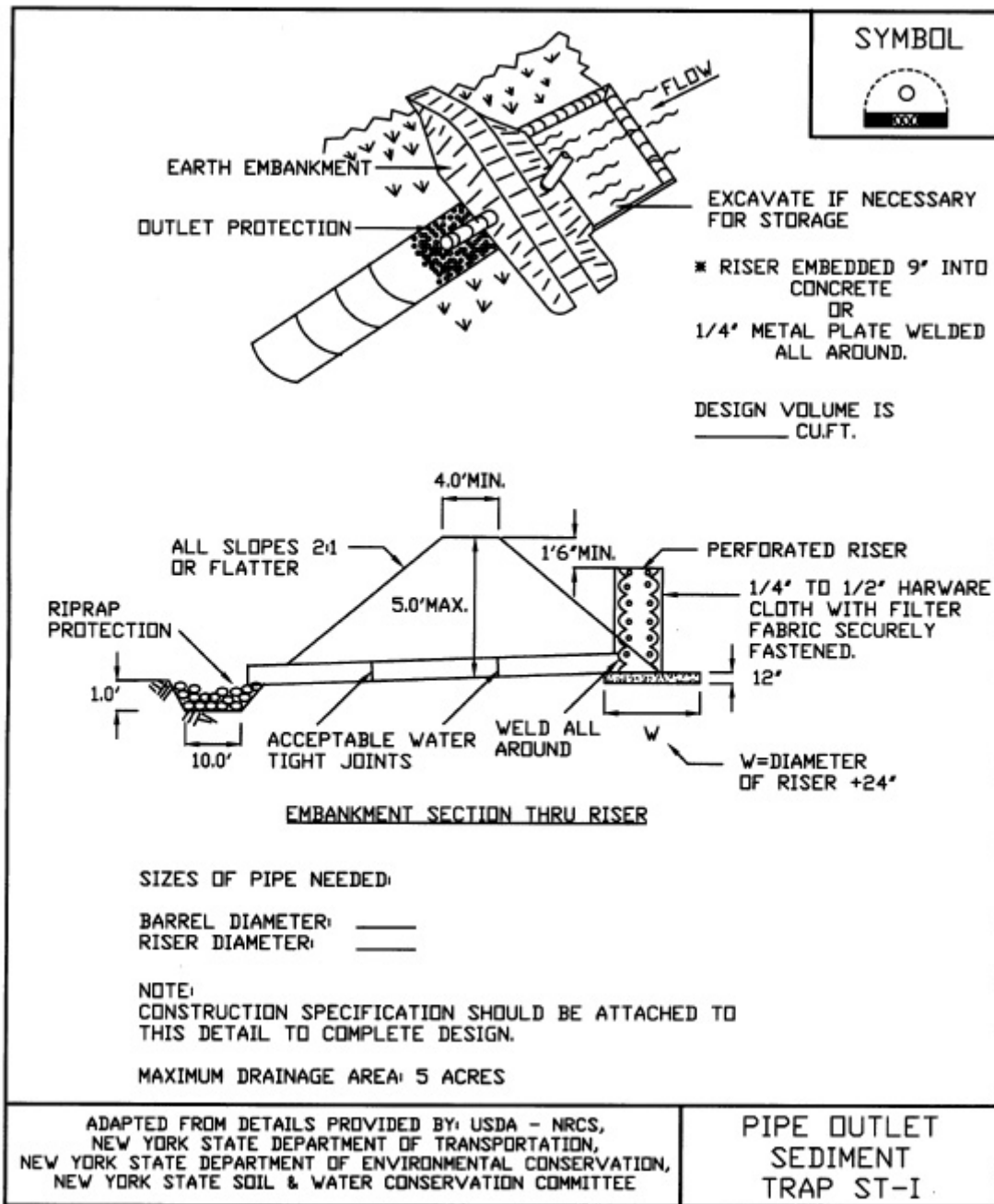



Figure A6.1 Pipe Outlet Sediment Trap

<b>CONSTRUCTION SPECIFICATIONS</b>		<b>SYMBOL</b> 
<ol style="list-style-type: none"> <li>1. AREA UNDER EMBANKMENT SHALL BE CLEARED, GRUBBED AND STRIPPED OF ANY VEGETATION AND ROOT MAT. THE POOL AREA SHALL BE CLEARED.</li> <li>2. THE FILL MATERIAL FOR THE EMBANKMENT SHALL BE FREE OF ROOTS OR OTHER WOODY VEGETATION AS WELL AS OVER-SIZED STONES, ROCKS, ORGANIC MATERIAL, OR OTHER OBJECTIONABLE MATERIAL. THE EMBANKMENT SHALL BE COMPACTED BY TRAVERSING WITH EQUIPMENT WHILE IT IS BEING CONSTRUCTED.</li> <li>3. VOLUME OF SEDIMENT STORAGE SHALL BE 5500 CUBIC FEET PER ACRE OF CONTRIBUTORY DRAINAGE.</li> <li>4. SEDIMENT SHALL BE REMOVED AND TRAP RESTORED TO ITS ORIGINAL DIMENSIONS WHEN THE SEDIMENT HAS ACCUMULATED TO 1/2 THE DESIGN DEPTH OF THE TRAP. REMOVED SEDIMENT SHALL BE DEPOSITED IN A SUITABLE AREA AND STABILIZED.</li> <li>5. THE STRUCTURE SHALL BE INSPECTED AFTER EACH RAIN AND REPAIRS MADE AS NEEDED.</li> <li>6. CONSTRUCTION OPERATIONS SHALL BE CARRIED OUT IN SUCH A MANNER THAT EROSION AND SEDIMENT ARE CONTROLLED.</li> <li>7. THE STRUCTURE SHALL BE REMOVED AND AREA STABILIZED WHEN THE DRAINAGE AREA HAS BEEN PROPERLY STABILIZED.</li> <li>8. ALL FILL SLOPES SHALL BE 2:1 OR FLATTER; CUT SLOPES 1:1 OR FLATTER.</li> <li>9. ALL PIPE CONNECTIONS SHALL BE WATERTIGHT.</li> <li>10. THE TOP 2/3 OF THE RISER SHALL BE PERFORATED WITH ONE (1) INCH DIAMETER HOLES OR SLITS SPACED SIX (6) INCHES VERTICALLY AND HORIZONTALLY AND PLACED IN THE CONCAVE PORTION OF PIPE. NO HOLES WILL BE ALLOWED WITHIN SIX (6) INCHES OF THE HORIZONTAL BARREL.</li> <li>11. THE RISER SHALL BE WRAPPED WITH 1/4 TO 1/2 INCH HARDWARE CLOTH WIRE THEN WRAPPED WITH FILTER CLOTH (HAVING AN EQUIVALENT SIEVE SIZE OF 40-80). THE FILTER CLOTH SHALL EXTEND SIX (6) INCHES ABOVE THE HIGHEST HOLE AND SIX (6) INCHES BELOW THE LOWEST HOLE. WHERE ENDS OF THE FILTER CLOTH COME TOGETHER, THEY SHALL BE OVER-LAPPED, FOLDED AND STAPLED TO PREVENT BYPASS.</li> <li>12. STRAPS OR CONNECTING BANDS SHALL BE USED TO HOLD THE FILTER CLOTH AND WIRE FABRIC IN PLACE. THEY SHALL BE PLACED AT THE TOP AND BOTTOM OF THE CLOTH.</li> <li>13. FILL MATERIAL AROUND THE PIPE SPILLWAY SHALL BE HAND COMPACTED IN FOUR (4) INCH LAYERS. A MINIMUM OF TWO (2) FEET OF HAND COMPACTED BACKFILL SHALL BE PLACED OVER THE PIPE SPILLWAY BEFORE CROSSING IT WITH CONSTRUCTION EQUIPMENT.</li> <li>14. THE RISER SHALL BE ANCHORED WITH EITHER A CONCRETE BASE OR STEEL PLATE BASE TO PREVENT FLOTATION. FOR CONCRETE BASED THE DEPTH SHALL BE TWELVE (12) INCHES WITH THE RISER EMBEDDED NINE (9) INCHES. A 1/4 INCH MINIMUM THICKNESS STEEL PLATE SHALL BE ATTACHED TO THE RISER BY A CONTINUOUS WELD AROUND THE BOTTOM TO FORM A WATERTIGHT CONNECTION AND THEN PLACE TWO (2) FEET OF STONE, GRAVEL, OR TAMPED EARTH ON THE PLATE.</li> </ol>		
ADAPTED FROM DETAILS PROVIDED BY: USDA - NRCS, NEW YORK STATE DEPARTMENT OF TRANSPORTATION, NEW YORK STATE DEPARTMENT OF ENVIRONMENTAL CONSERVATION, NEW YORK STATE SOIL & WATER CONSERVATION COMMITTEE		<b>PIPE OUTLET                  SEDIMENT TRAP                  ST-I</b>

**Figure A6.2 Pipe Outlet Sediment Trap – Construction Specifications**



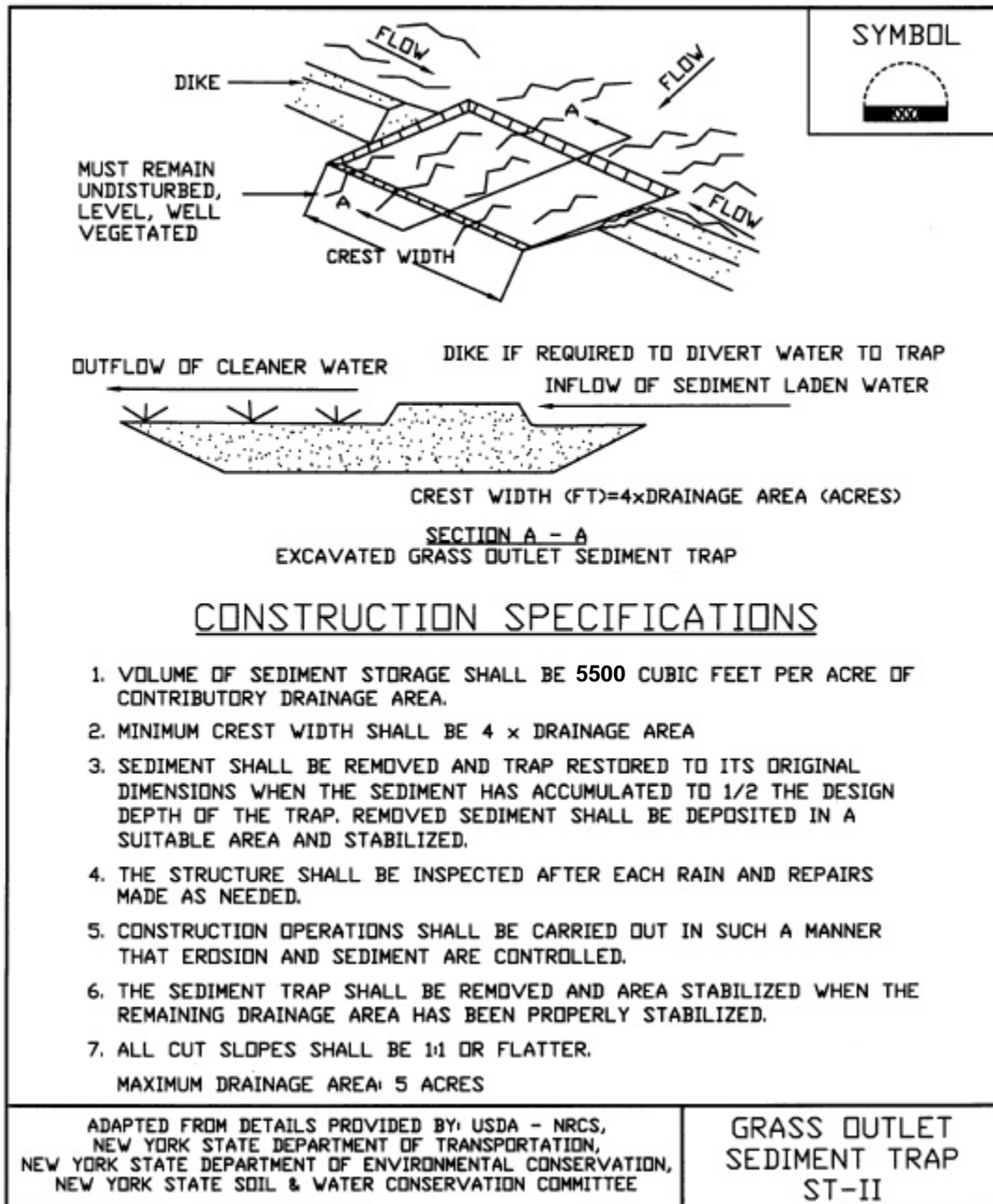

Figure A6.3 Grass Outlet Sediment Trap

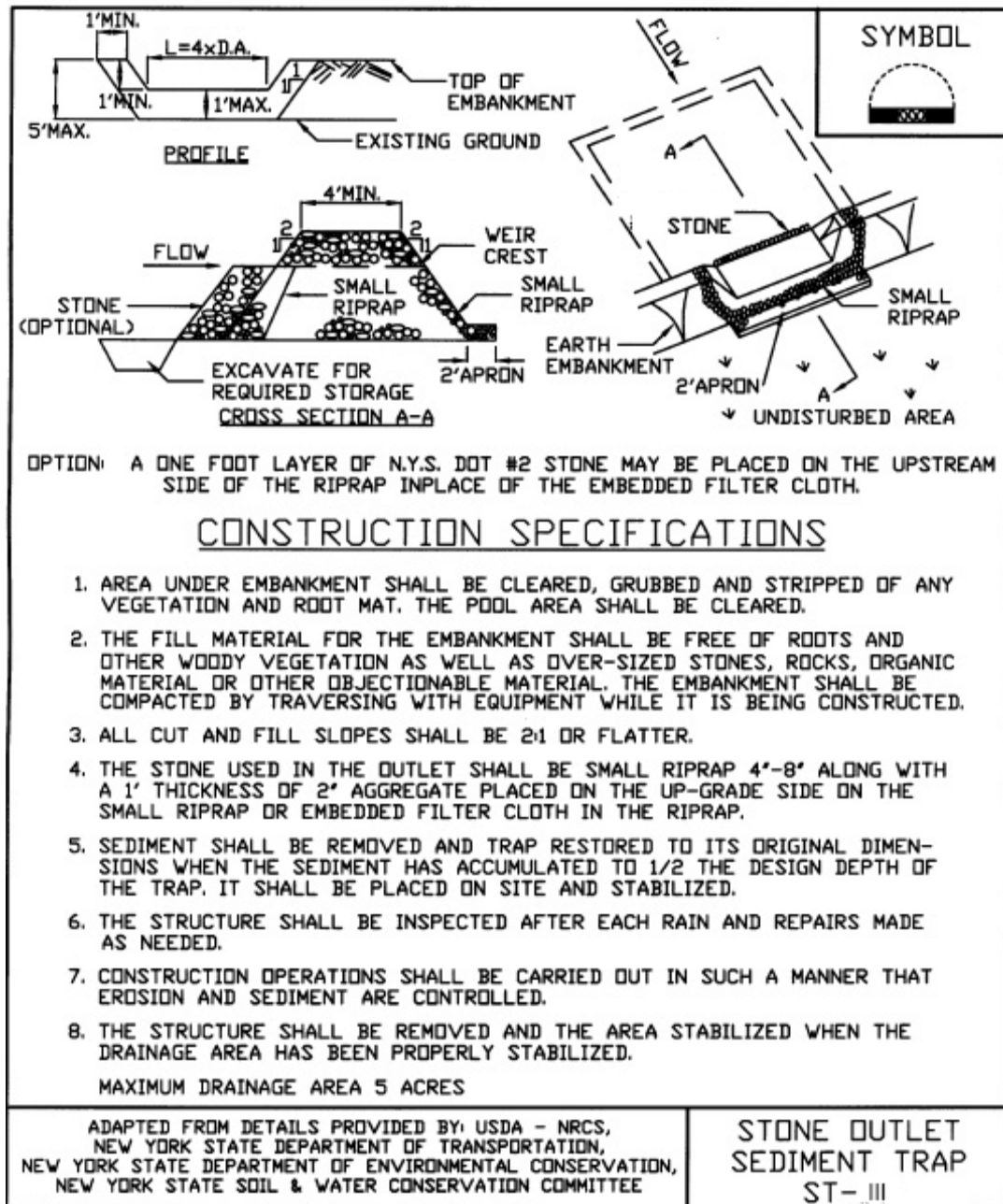

Figure A6.4 Stone Outlet Sediment Trap

## **A7: Silt Fence**

### **Definition**

A temporary barrier of geotextile fabric installed on the contours across a slope used to intercept sediment laden runoff from small drainage areas of disturbed soil.

### **Purpose**

The purpose of a silt fence is to reduce runoff velocity and effect deposition of transported sediment load. Limits imposed by ultraviolet stability of the fabric will dictate the maximum period the silt fence may be used (approximately one year).

### **Conditions Where Practice Applies**

A silt fence may be used subject to the following conditions:

1. Maximum allowable slope lengths contributing runoff to a silt fence placed on a slope are:

<u>Slope Steepness</u>	<u>Maximum Length (ft. )</u>
2:1	25
3:1	50
4:1	75
5:1 or flatter	100

2. Maximum drainage area for overland flow to a silt fence shall not exceed  $\frac{1}{4}$  acre per 100 feet of fence, with maximum ponding depth of 1.5 feet behind the fence; and

3. Erosion would occur in the form of sheet erosion; and

4. There is no concentration of water flowing to the barrier.

### **Design Guidance**

Design computations are not required for installations of 1 month or less. Longer installation periods should be designed for expected runoff. All silt fences shall be placed as close to the areas as possible, but at least 10 feet from the toe of a slope to allow for maintenance and roll down. The area beyond the fence must be undisturbed or stabilized.

Sensitive areas to be protected by silt fence may need to be reinforced by using heavy wire fencing for added support to prevent collapse.

Where ends of filter cloth come together, they shall be overlapped, folded and stapled to prevent sediment bypass.

See **Figure A7.1** for details.

## Criteria for Silt Fence Materials

1. Silt Fence Fabric: The fabric shall meet the following specifications unless otherwise approved by the appropriate erosion and sediment control plan approval authority. Such approval shall not constitute automatic future acceptance throughout the Territory or Commonwealth.

<u>Fabric Properties</u>	<u>Minimum Acceptable Value</u>	<u>Test Method</u>
Grab Tensile Strength (lbs)	90	ASTM D1682
Elongation at Failure (%)	50	ASTM D1682
Mullen Burst Strength (PSI)	190	ASTM D3786
Puncture Strength (lbs)	40	ASTM D751 (modified)
Slurry Flow Rate (gal/min/sf)	0.3	
Equivalent Opening Size	40-80	US Std Sieve CW-02215
Ultraviolet Radiation Stability (%)	90	ASTM G-26

2. Fence Posts (for fabricated units): The length shall be a minimum of 36 inches long. Wood posts will be of sound quality hardwood with a minimum cross sectional area of 3.0 square inches. Steel posts will be standard T and U section weighing not less than 1.00 pound per linear foot.

3. Wire Fence (for fabricated units): Wire fencing shall be a minimum 14 gage with a maximum 6 in. mesh opening, or as approved.

4. Prefabricated Units: Envirofence, Geofab, or approved equal, may be used in lieu of the above method providing the unit is installed per details shown in **Figure A7.1**.

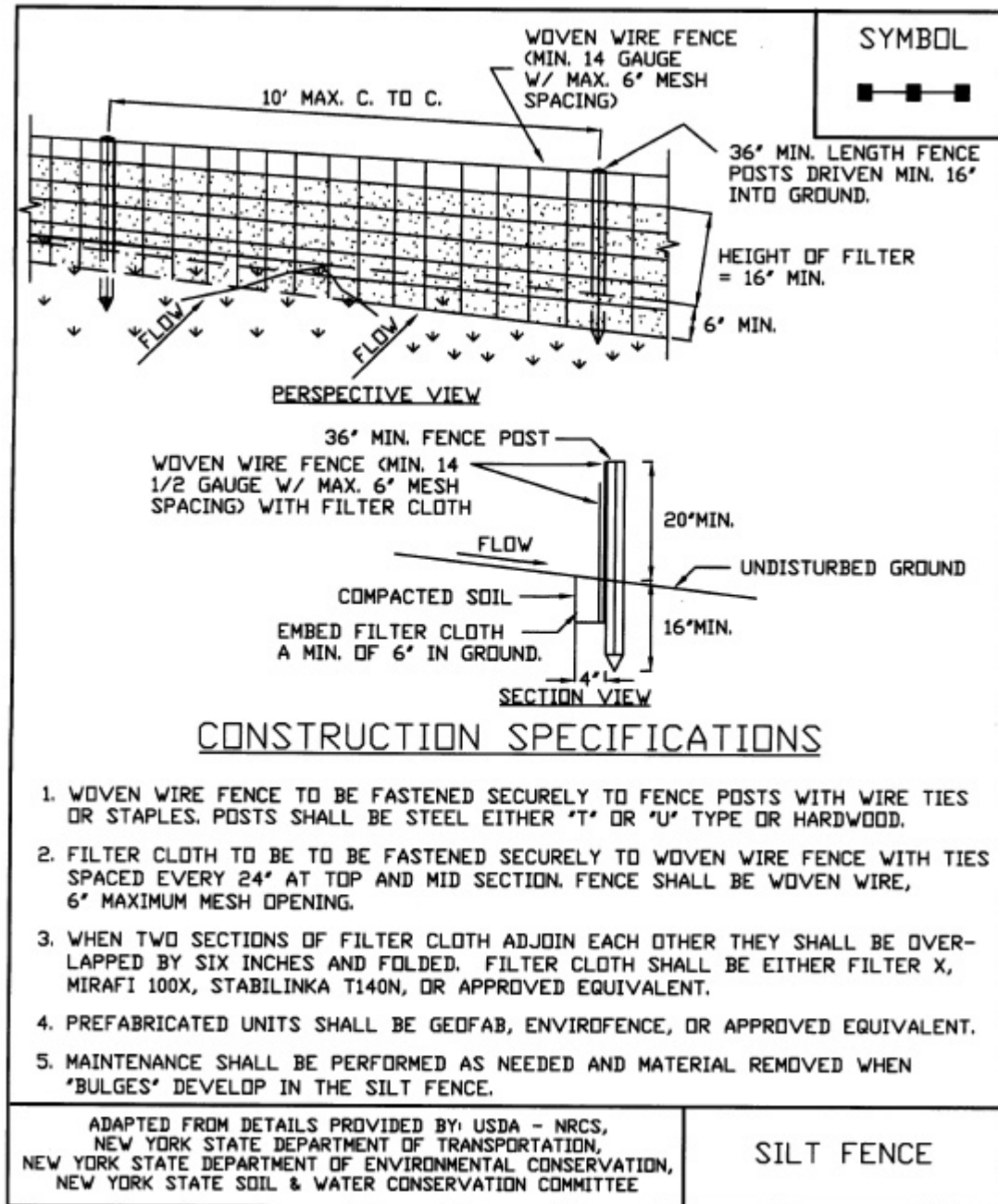

Figure A7.1 Silt Fence

## **A8: Stabilized Construction Entrance**

### **Definition**

A stabilized pad of aggregate underlain with geotextile located at any point where traffic will be entering or leaving a construction site to or from a public right-of-way, street, alley, sidewalk, or parking area.

### **Purpose**

The purpose of stabilized construction entrance is to reduce or eliminate the tracking of sediment onto public rights-of way or streets.

### **Conditions Where Practice Applies**

A stabilized construction entrance shall be used at all points of construction ingress and egress.

### **Design Guidance** (See **Figure A8.1** for details)

**Aggregate Size:** Use a matrix of 1-4 inch stone, or reclaimed or recycled concrete equivalent.

**Thickness:** Not less than six (6) inches.

**Width:** 12-foot minimum but not less than the full width of points where ingress or egress occurs. 24-foot minimum if there is only one access to the site.

**Length:** As required, but not less than 50 feet (except on a single residence lot where a 30 foot minimum would apply).

**Geotextile:** To be placed over the entire area to be covered with aggregate. Filter cloth will not be required on a single family residence lot. Piping of surface water under entrance shall be provided as required. If piping is impossible, a mountable berm with 5:1 slopes will be permitted.

**Criteria for Geotextile:** The geotextile shall be woven or nonwoven fabric consisting only of continuous chain polymeric filaments or yarns of polyester. The fabric shall be inert to commonly encountered chemicals, hydro-carbons, mildew, rot resistant, and conform to the fabric properties as shown:

Fabric Properties <sup>3</sup>	Light Duty <sup>1</sup>	Heavy Duty <sup>2</sup>	Test Method
	Roads Grade Subgrade	Haul Roads Rough Graded	
Grab Tensile Strength (lbs)	200	220	ASTM D1682
Elongation at Failure (%)	50	60	ASTM D1682
Mullen Brust Strength (lbs)	190	430	ASTM D3786
Puncture Strength (lbs)	40	125	ASTM D751 modified
Equivalent	40-80	40-80	US Std Sieve

Opening Size			CW-02215
Aggregate Depth	6	10	–

1-Light Duty Road: Area sites that have been graded to subgrade and where most travel would be single axle vehicles and an occasional multi-axle truck. Acceptable materials are Trevira Spunbond 1115, Mirafi 100X, Typar 3401, or equivalent.

2-Heavy Duty Road: Area sites with only rough grading, and where most travel would be multi-axle vehicles. Acceptable materials are Trevira Spunbond 1135, Mirafi 600X, or equivalent.

3-Fabrics not meeting these specifications may be used only when design procedure and supporting documentation are supplied to determine aggregate depth and fabric strength.

### **Maintenance**

The entrance shall be maintained in a condition which will prevent tracking of sediment onto public rights-of-way or streets. This may require periodic top dressing with additional aggregate. All sediment spilled, dropped, or washed onto public rights-of-way must be removed immediately.

When necessary, wheels must be cleaned to remove sediment prior to entrance onto public rights-of-way. When washing is required, it shall be done on an area stabilized with aggregate, which drains into an approved sediment-trapping device. All sediment shall be prevented from entering storm drains, ditches, or watercourses.

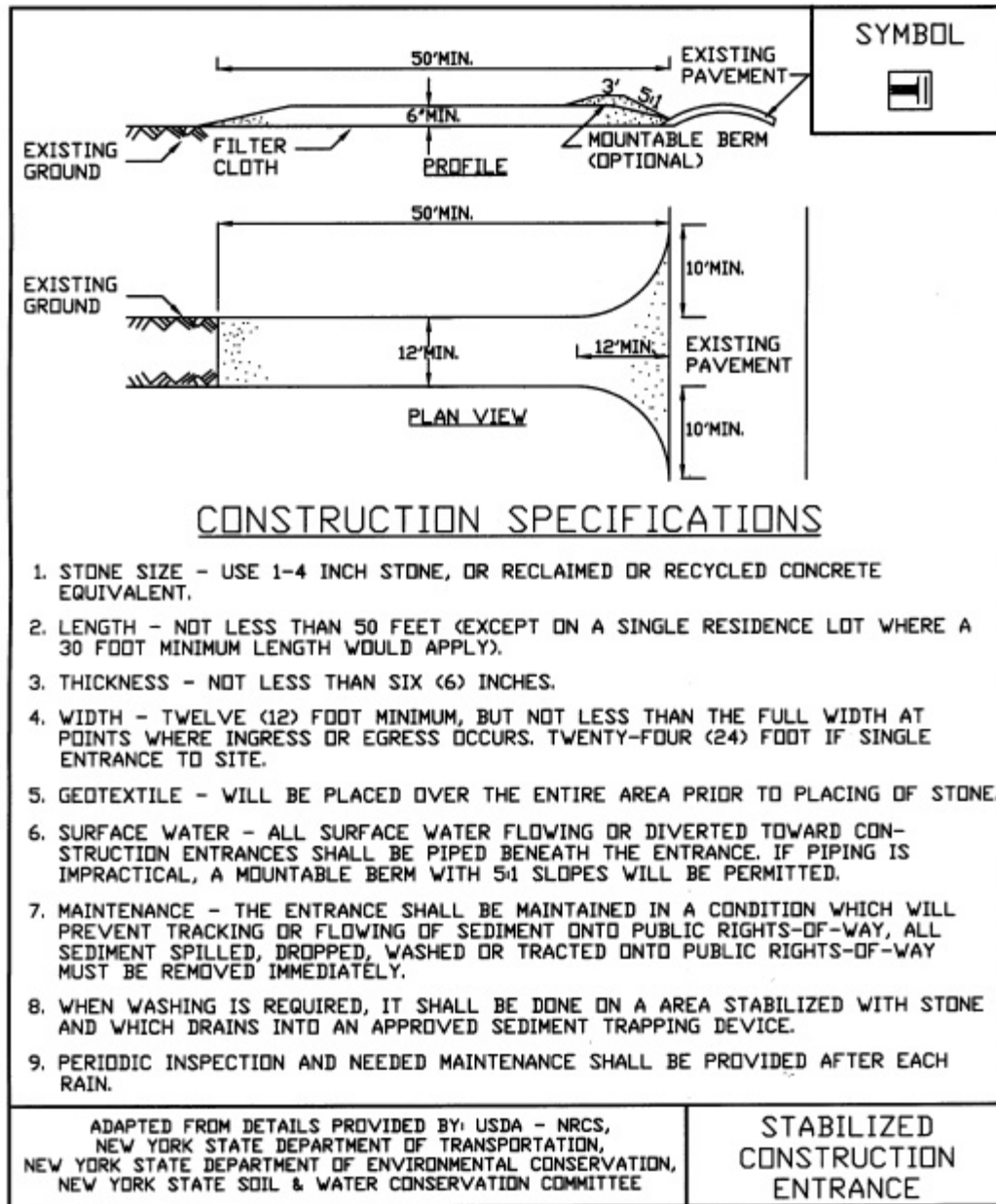

Figure A8.1 Stabilized Construction Entrance



## **A9: Storm Drainage Inlet Protection**

### **Definition**

A temporary, somewhat permeable barrier, installed around inlets in the form of a fence, berm or excavation around an opening, trapping water and thereby reducing the sediment content of sediment laden water by settling.

### **Purpose**

To prevent heavily sediment laden water from entering a storm drain system through inlets.

### **Conditions Where Practice Applies**

This practice shall be used where the drainage area to an inlet is disturbed, it is not possible to temporarily divert the storm drain outfall into a trapping device, and watertight blocking of inlets is not advisable. **It is not to be used in place of sediment trapping devices.** This may be used in conjunction with storm drain diversion to help prevent siltation of pipes installed with low slope angle.

### **Types of Storm Drain Inlet Practices**

There are four (4) specific types of storm drain inlet protection practices that vary according to their function, location, drainage area, and availability of materials:

- I. Excavated Drop Inlet Protection
- II. Fabric Drop Inlet Protection
- III. Stone & Block Drop Inlet Protection
- IV. Curb Drop Inlet Protection

### **Design Guidance**

**Drainage Area** – The drainage area for storm drain inlets shall not exceed one acre. The crest elevations of these practices shall provide storage and minimize bypass flow.

#### ***Type I – Excavated Drop Inlet Protection***

Limit the drainage area to the inlet device to 1 acre. Excavated side slopes shall be no steeper than 2:1. The minimum depth shall be 1 foot and the maximum depth 2 feet as measured from the crest of the inlet structure. Shape the excavated basin to fit conditions with the longest dimension oriented toward the longest inflow area to provide maximum trap efficiency. The capacity of the excavated basin should be established to contain 900 cubic feet per acre of disturbed area. Weep holes, protected by fabric and stone, should be provided for draining the temporary pool. Inspect and clean the excavated basin after every storm. Sediment should be removed when 50 percent of the storage volume is achieved.. This material should be incorporated into the site in a stabilized manner.

#### ***Type II – Fabric Drop Inlet Protection***

Limit the drainage area to 1 acre per inlet device. Land area slope immediately surrounding this device should not exceed 1 percent. The maximum height of the fabric above the inlet crest shall not exceed 1.5 feet unless reinforced. The top of the barrier should be maintained to allow overflow to drop into the drop inlet and not bypass the inlet to unprotected lower areas. Support stakes for fabric shall be a minimum of 3 feet long, spaced a maximum 3 feet apart. They should

be driven close to the inlet so any overflow drops into the inlet and not on the unprotected soil. Improved performance and sediment storage volume can be obtained by excavating the area. Inspect the fabric barrier after each rain event and make repairs as needed. Remove sediment from the pool area as necessary with care not to undercut or damage the filter fabric. Upon stabilization of the drainage area, remove all materials and unstable sediment and dispose of properly. Bring the adjacent area of the drop inlet to grade, smooth and compact and stabilize in the appropriate manner to the site.

### ***Type III – Stone and Block Drop Inlet Protection***

Limit the drainage area to 1 acre at the drop inlet. The stone barrier should have a minimum height of 1 foot and a maximum height of 2 feet. Do not use mortar. The height should be limited to prevent excess ponding and bypass flow. Recess the first course of blocks at least 2 inches below the crest opening of the storm drain for lateral support. Subsequent courses can be supported laterally if needed by placing a 2x4 inch wood stud through the block openings perpendicular to the course. The bottom row should have a few blocks oriented so flow can drain through the block to dewater the basin area. The stone should be placed just below the top of the blocks on slopes of 2:1 or flatter. Place hardware cloth of wire mesh with ½-inch openings over all block openings to hold stone in place. As an optional design, the concrete blocks may be omitted and the entire structure constructed of stone, ringing the outlet (“doughnut”). The stone should be kept at a 3:1 slope toward the inlet to keep it from being washed into the inlet. A level area 1 foot wide and four inches below the crest will further prevent wash. Stone on the slope toward the inlet should be at least 3 inches in size for stability and 1 inch or smaller away from the inlet to control flow rate. The elevation of the top of the stone crest must be maintained 6 inches lower than the ground elevation down slope from the inlet to ensure that all storm flows pass over the stone into the storm drain and not past the structure. Temporary diking should be used as necessary to prevent bypass flow.

The barrier should be inspected after each rain event and repairs made where needed. Remove sediment as necessary to provide for accurate storage volume for subsequent rains. Upon stabilization of contributing drainage area, remove all materials and any unstable soil and dispose of properly. Bring the disturbed area to proper grade, smooth, compact and stabilized in a manner appropriate to the site.

### ***Type IV – Curb Drop Inlet Protection***

The drainage area should be limited to 1 acre at the drop inlet. The wire mesh must be of sufficient strength to support the filter fabric and stone with the water fully impounded against it. Stone is to be 2 inches in size and clean. The filter fabric must be of a type approved for this purpose with an equivalent opening size (EOS) of 40-85. The protective structure will be constructed to extend beyond the inlet 2 feet in both directions. Assure that storm flow does not bypass the inlet by installing temporary dikes (such as sand bags) directing flow into the inlet. Make sure that the overflow weir is stable. Traffic safety shall be integrated with the use of this practice. The structure should be inspected after every storm event. Any sediment should be removed and disposed of on the site. Any stone missing should be replaced. Check materials for proper anchorage and secure as necessary.

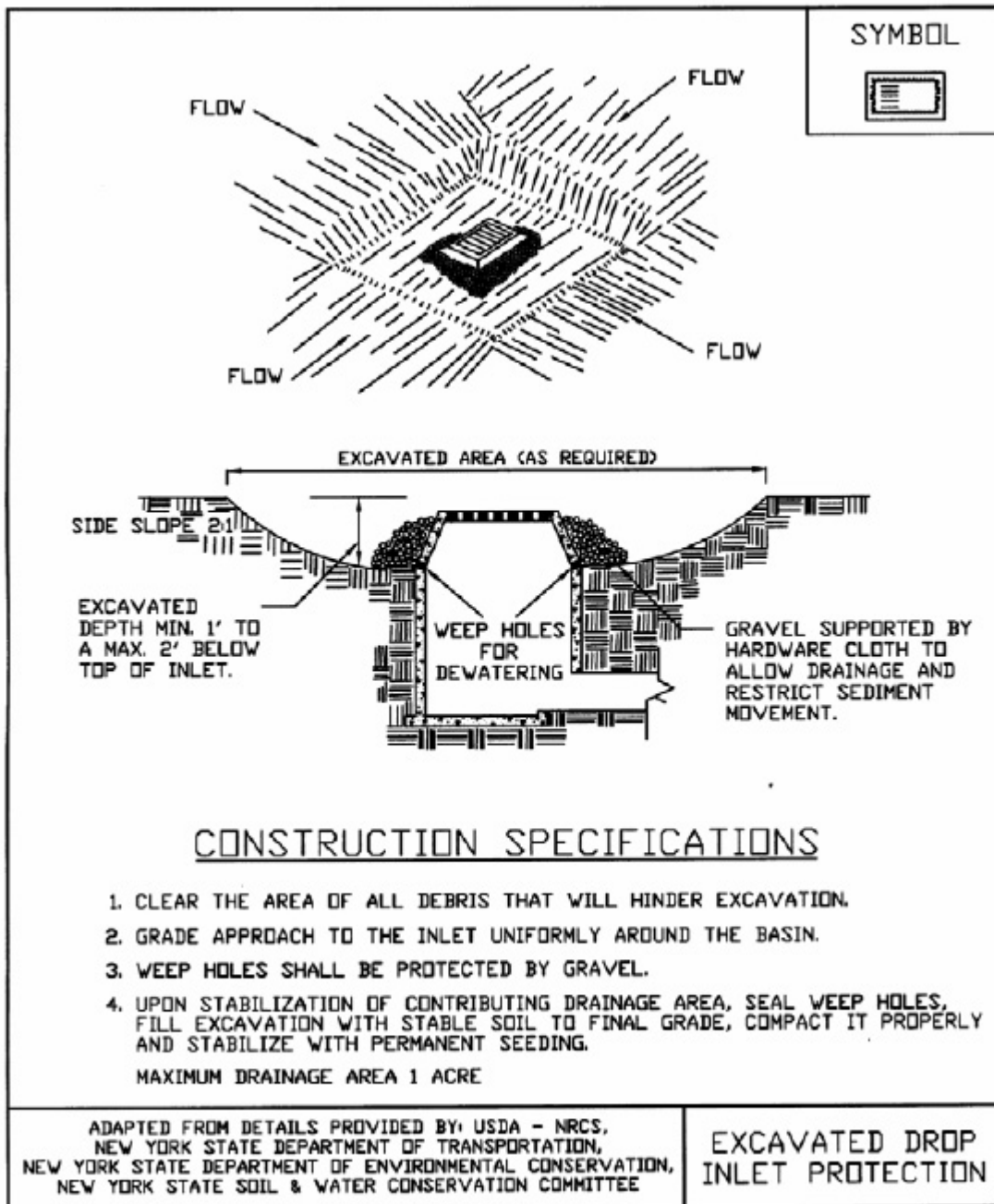

Figure A9.1 Excavated Drop Inlet Protection

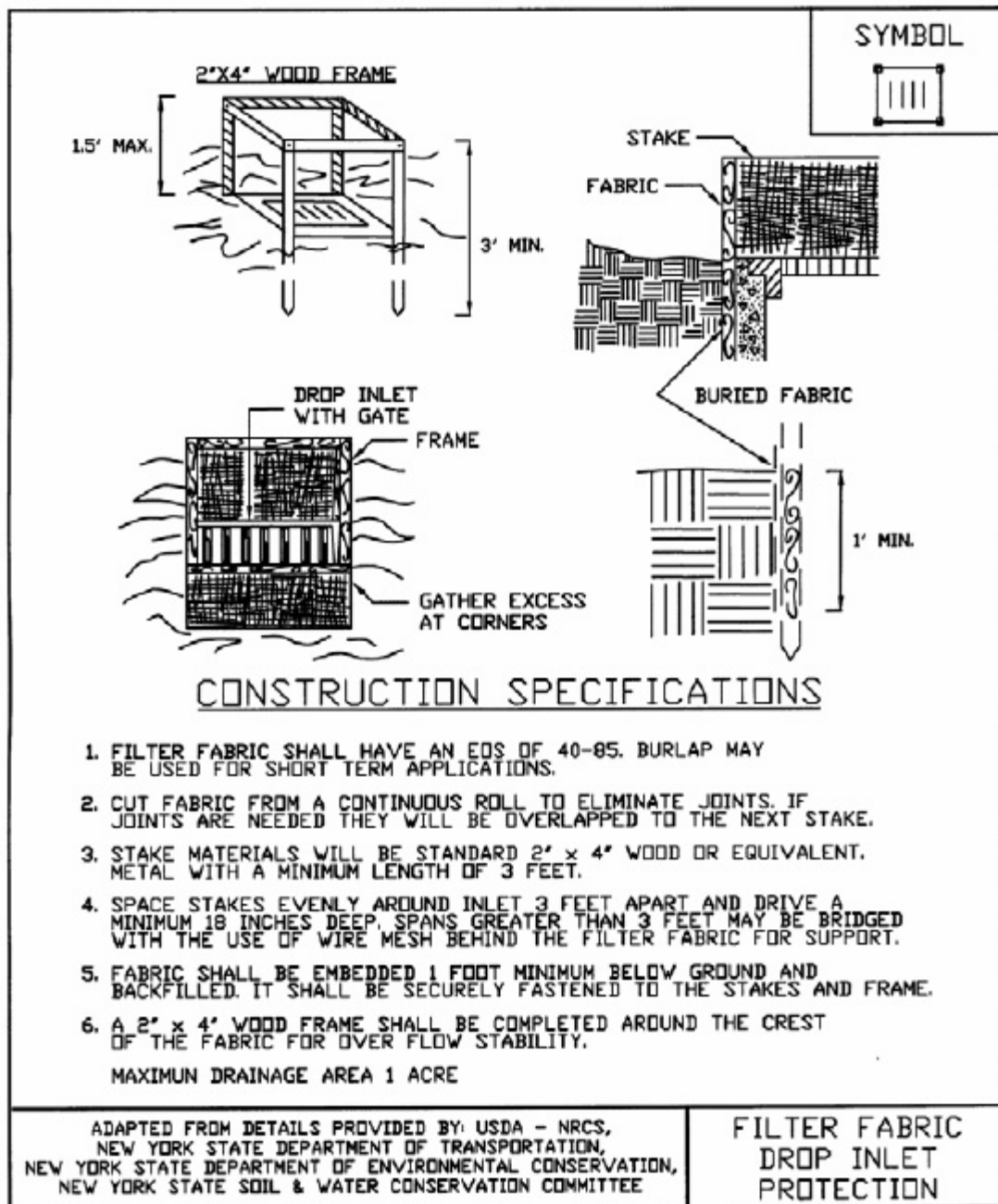

Figure A9.2 Filter Fabric Drop Inlet Protection

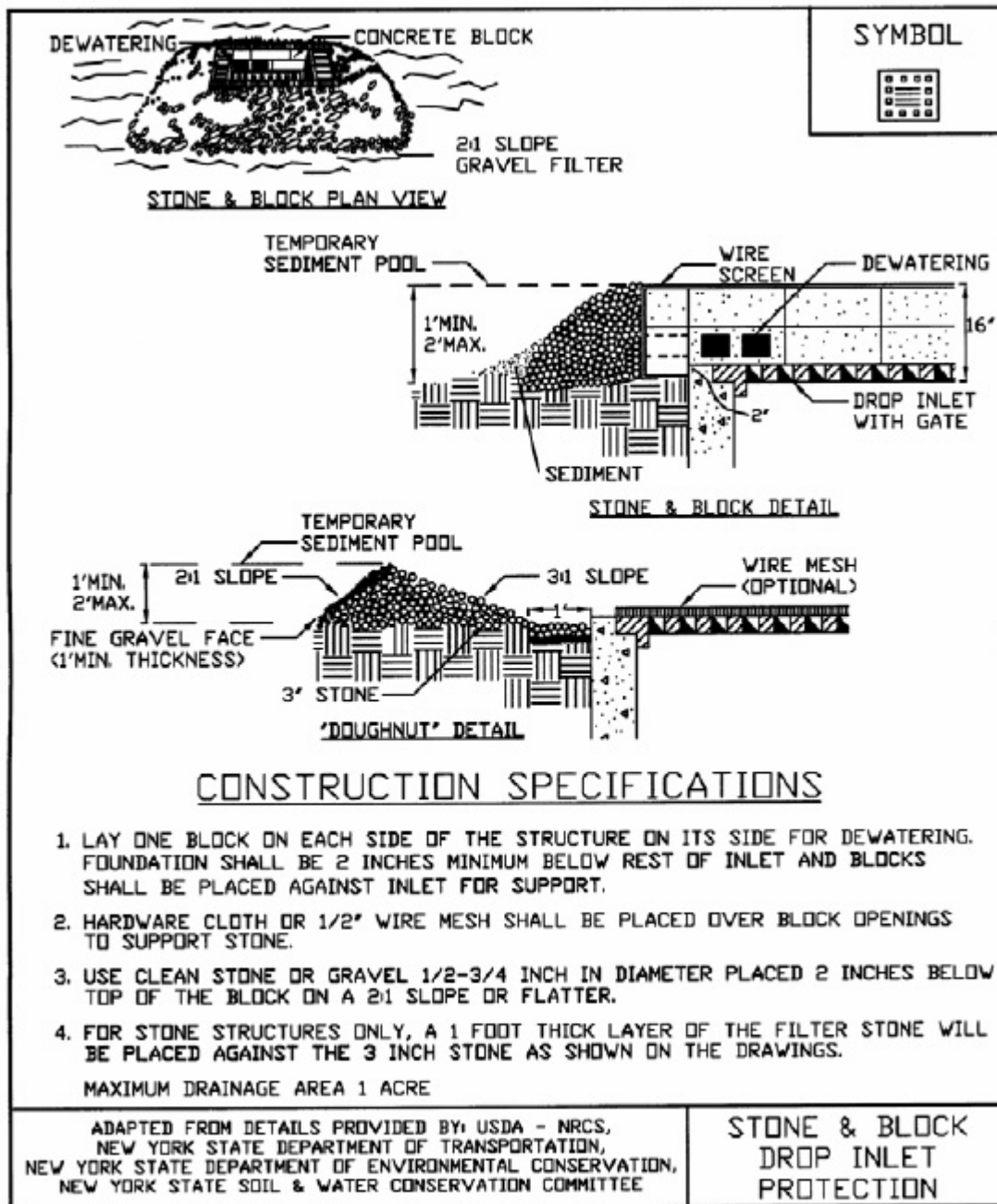

Figure A9.3 Stone and Block Drop Inlet Protection

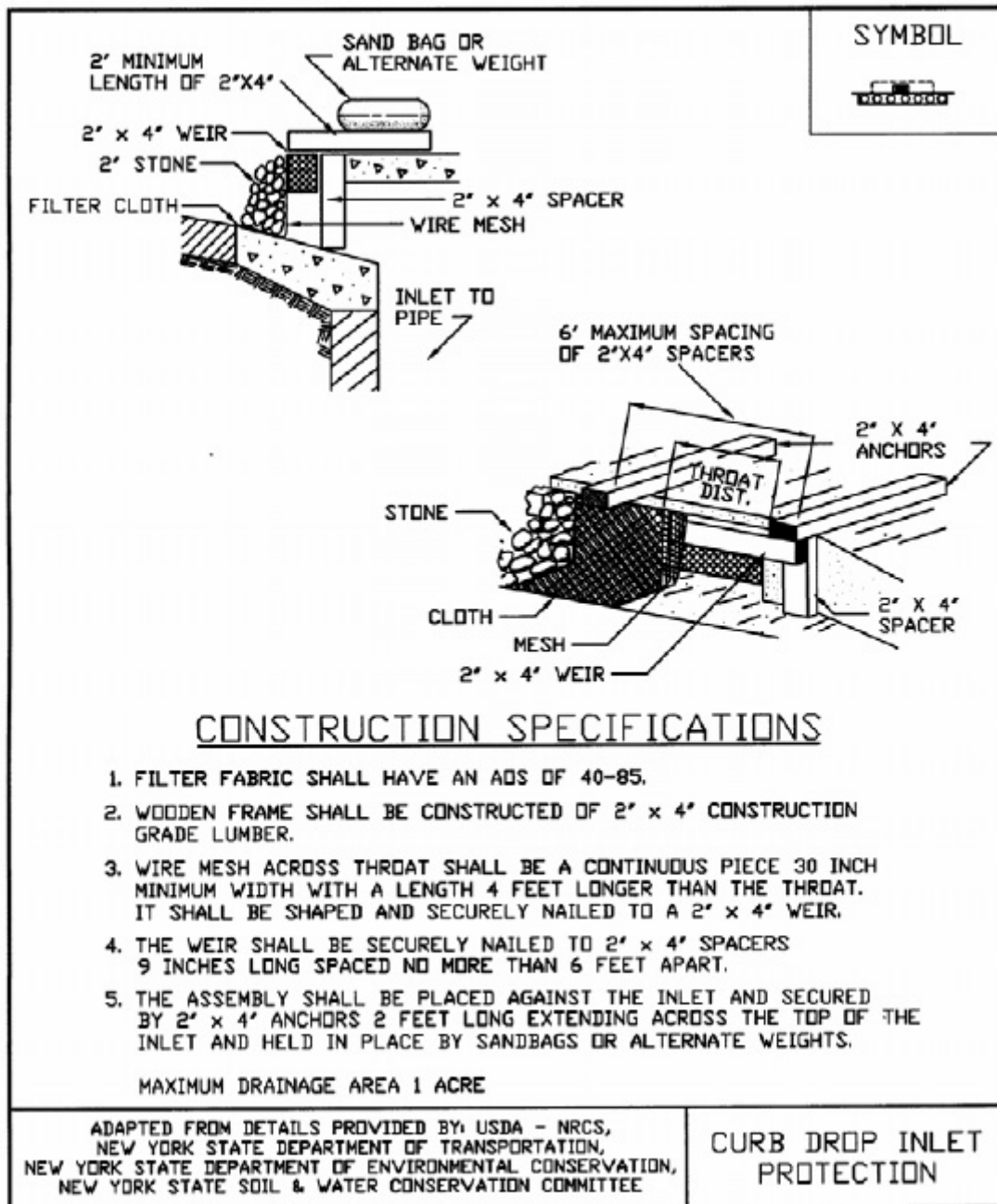

Figure A9.4 Curb Drop Inlet Protection

## **A10: Turbidity Curtain**

### **Definition**

A flexible, impenetrable barrier used to trap sediment in water bodies. This curtain is weighted at the bottom to achieve closure while supported at the top through a flotation system.

### **Purpose**

To prevent the migration of silt from a work site in a water environment into the larger body of water.

### **Conditions Where Practice Applies**

A turbidity curtain is generally used when construction activity occurs within a waterbody or along its shoreline and is of short duration, generally less than one month. Curtains are used in calm water surfaces. **Turbidity curtains are not to be used across flowing watercourses.**

### **Design Criteria**

The turbidity curtain shall be located beyond the lateral limits of the construction site and firmly anchored in place. The alignment should be set as close to the work area as possible but not so close as to be disturbed by applicable construction equipment. The height of the curtain shall be 20% greater than the depth of the water to allow for water level fluctuations. The area that the turbidity curtain protects shall not contain large culverts or drainage areas that if flows occur behind the curtain would cause a breach or lost contact at the bottom surface. If water depths at the design alignment are minimal, the toe can be anchored in place by staking.

### **Construction Specifications**

The area of proposed installation of the curtain shall be inspected for obstacles and impediments that could damage the curtain or impair its effectiveness to retain sediment. All materials shall be removed so they cannot enter the waterbody. Shallow installations can be made by securing the curtain by staking rather than using a flotation system. Supplemental anchors of the turbidity curtain toe shall be used, as needed, depending on water surface disturbances such as boats and wave action by winds.

### **Maintenance**

The turbidity curtain shall be inspected daily and repaired or replaced immediately. It is not normally necessary to remove sediment deposited behind the curtain; but, when necessary, removal is usually done by hand prior to removal of the barrier. All removed silt is stabilized away from the waterbody. The barrier shall be removed by carefully pulling it toward the construction site to minimize the release of attached sediment. Any floating construction or natural debris shall be immediately removed to prevent damage to the curtain. If the curtain is oriented in a manner that faces the prevailing winds, frequent checks of the anchorage shall be made.

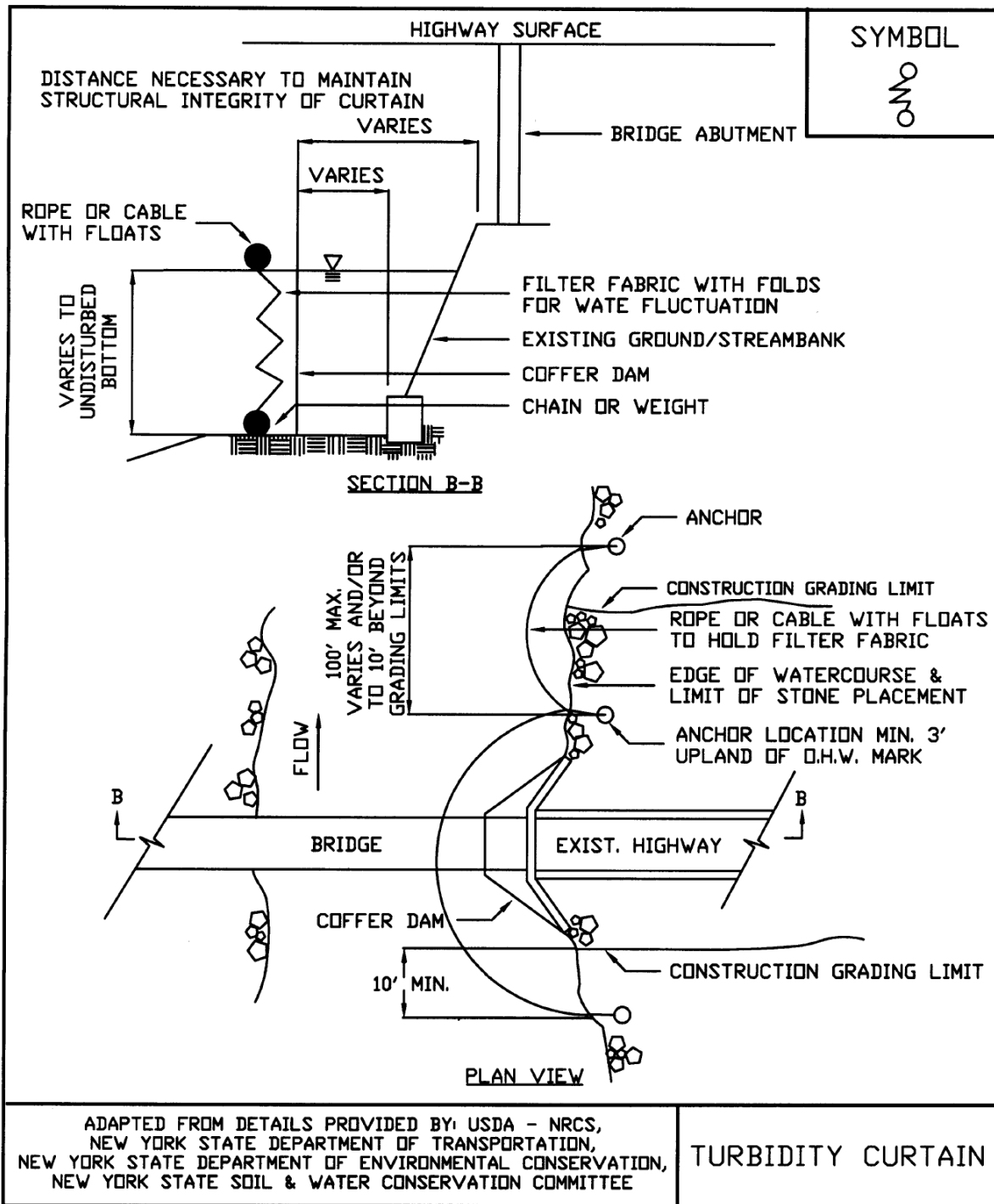

Figure A10.1 Turbidity Curtain



## **A11: Vegetated and Lined Waterways**

### **Definitions**

**Waterway** - A drainage way of parabolic or trapezoidal cross-section with a supporting ridge on the lower side that is constructed across the slope.

**Grassed/Vegetated Waterway** - A natural or man-made channel of parabolic or trapezoidal cross-section that is below adjacent ground level and is stabilized by suitable vegetation. The flow channel is normally wide and shallow and conveys the runoff down the slope.

**Lined Waterway** - A waterway or outlet with a lining of concrete, stone, or other permanent material. The lined section extends up the side slopes to the designed depth. The earth above the permanent lining may be vegetated or otherwise protected.

### **Purpose**

**Waterway** - The purpose of a diversion waterway is to intercept and convey runoff to stable outlets at non-erosive velocities.

**Grassed/Vegetated Waterway** - The purpose of a grassed waterway is to convey runoff from construction sites and urban areas without causing damage by erosion.

**Lined Waterway** - To provide for the disposal of concentrated runoff without damage from erosion or flooding, where grassed waterways would be inadequate due to high velocities.

### **Conditions Where Practice Applies**

**Waterway** – Diversion Waterways are used where:

1. Runoff from higher areas has potential for damaging properties, causing erosion, or interfering with, or preventing the establishment of, vegetation on lower areas.
2. Surface and/or shallow subsurface flow is damaging sloping upland.
3. The length of slopes needs to be reduced so that soil loss will be kept to a minimum.

Diversion Waterways are only applicable below stabilized or protected areas. Avoid establishment on slopes greater than fifteen percent. Diversion Waterways should be used with caution on soils subject to slippage. Construction of diversions shall be in compliance with local drainage and water laws.

**Grassed/Vegetated Waterway** – Grass/vegetated waterways are used where added vegetative protection is needed to control erosion resulting from concentrated runoff. Supplemental measures may be required with this practice. These may include: subsurface drainage to permit the growth of suitable vegetation and to eliminate wet spots; a section stabilized with asphalt, stone, or other suitable means; or additional storm drains to handle storm runoff.

**Lined Waterway** - This standard applies to waterways or outlets with linings of cast-in-place concrete, flagstone mortared in place, rock riprap, gabions, or similar permanent linings. It does not apply to irrigation ditch or canal linings, grassed waterways with stone centers or small lined sections that carry prolonged low flows, or to reinforced concrete channels. The maximum capacity of the waterway flowing at design depth shall not exceed 100 cubic feet per second.

This practice applies where the following or similar conditions exist:

1. Concentrated runoff is such that a lining is required to control erosion.

2. Steep grades, wetness, prolonged base flow, seepage, or piping that would cause erosion.
3. The location is such that damage from use by people or animals precludes use of vegetated waterways or outlets.
4. Soils are highly erosive or other soil and climate conditions preclude using vegetation.
5. High value property or adjacent facilities warrant the extra cost to contain design runoff in a limited space.

### **Guidance for General Waterway Design**

**Location** - Diversion location shall be determined by considering outlet conditions, topography, land use, soil type, length of slope, seep planes (when seepage is a problem), and the development layout.

**Capacity** - Peak rates of runoff values used in determining the capacity requirements shall be computed by TR-55, Urban Hydrology for Small Watersheds, or other appropriate methods. The constructed diversion shall have capacity to carry, as a minimum, the peak discharge from a 10-year design storm event with freeboard of not less than 0.3 feet. Diversions designed to protect homes, schools, industrial buildings, roads, parking lots, and comparable high-risk areas, and those designed to function in connection with other structures, shall have sufficient capacity to carry peak runoff expected from a storm frequency consistent with the hazard involved.

**Cross Section** - The diversion channel shall be parabolic or trapezoidal in shape. The diversion shall be designed to have stable side slopes. The side slopes shall not be steeper than 2:1 and shall be flat enough to ensure ease of maintenance of the diversion and its protective vegetative cover. The ridge shall have a minimum width of four feet at the design water elevation; a minimum of 0.3 feet freeboard and a reasonable settlement factor shall be provided.

**Velocity and Grade** - The permissible velocity for the specified method of stabilization will determine the maximum grade. Diversions are not usually applicable below high sediment producing areas unless land treatment practices or structural measures, designed to prevent damaging accumulations of sediment in the channels, are installed with, or before, the diversions.

**Outlets** - Each diversion must have an adequate outlet. The outlet may be a grassed waterway, vegetated or paved area, grade stabilization structure, stable watercourse, or subsurface drain outlet. In all cases, the outlet must convey runoff to a point where outflow will not cause damage. Vegetated outlets shall be installed before diversion construction, if needed, to ensure establishment of vegetative cover in the outlet channel. The design elevation of the water surface in the diversion shall not be lower than the design elevation of the water surface in the outlet at their junction when both are operating at design flow.

**Stabilization** - Diversions shall be stabilized in accordance with the following tables.

**Construction Specifications** - See **Figure A11.1** for details.

**Guidance for Grassed/Vegetated Waterways**

Waterways or outlets shall be protected against erosion by vegetative means as soon after construction as practical. Vegetation must be well established before diversions or other channels are outletted into them. Consideration should be given to the use of synthetic products, jute or excelsior matting, or other rolled erosion control products to provide erosion protection as soon after construction as possible. It is strongly recommended that the center line of the waterway be protected with one of the above materials to avoid center gullies.

If rills develop in the centerline of a waterway, prompt attention is required to avoid the formation of gullies. Either stone and/or compacted soil fill with excelsior or filter fabric as necessary may be used during the establishment phase.

**Capacity** - The minimum capacity shall be that required to confine the peak rate of runoff expected from a design rainfall event or a higher frequency corresponding to the hazard involved. This requirement for confinement may be waived on slopes of less than one (1) percent where out-of-bank flow will not cause erosion or property damage. Peak rates of runoff values used in determining the capacity requirements shall be computed by TR-55, Urban Hydrology for Small Watersheds, or other appropriate methods. Where there is base flow, it shall be handled by a stone center, subsurface drain, or other suitable means since sustained wetness usually prevents adequate vegetative cover. The cross-sectional area of the stone center or subsurface drain size to be provided shall be determined by using a flow rate of 0.1 cfs/acre or by actual measurement of the maximum base flow.

**Velocity** – Must be designed to not exceed erodible velocities based upon materials used.

**Cross Section** - The design water surface elevation of a grassed waterway receiving water from diversions or other tributary channels shall be equal to or less than the design water surface elevation in the diversion or other tributary channels. The top width of parabolic waterways shall not exceed 30 feet and the bottom width of trapezoidal waterways shall not exceed 15 feet unless multiple or divided waterways, stone center, or other means are provided to control meandering of low flows.

**Structural Measures** - In cases where grade or erosion problems exist, special control measures may be needed such as lined waterways. Where needed, these measures will be supported by adequate design computations.

**Outlets** - Each waterway shall have a stable outlet. The outlet may be another waterway, a stabilized open channel, grade stabilization structure, etc. In all cases, the outlet must discharge in such a manner as not to cause erosion. Outlets shall be constructed and stabilized prior to the operation of the waterway.

**Stabilization** - Waterways shall be stabilized in accordance with the appropriate vegetative stabilization standard and specifications, and will be dependent on such factors as slope, soil class, etc.

**Construction Specifications** - See **Figure A11.2** for details.

## Guidance for Lined Waterways

### Capacity

1. The minimum capacity shall be adequate to carry the peak rate of runoff from the 10-year design storm. Velocity shall be computed using Manning's equation with a coefficient of roughness "n" as follows:

Lined Material	"n"
Concrete (Type):	
Trowel Finish	0.015
Float Finish	0.019
Gunite	0.019
Flagstone	0.022
Riprap	varies
Gabion	0.030

2. Riprap gradation and filter (bedding) are generally designed in accordance with criteria set forth in the National Cooperative Highway Research Program Report 108, available from the University Microfilm International, 300 N. Zeeb Road, Ann Arbor, Michigan 48016, Publication No. PB-00839; or the Hydraulic Engineering Circular No. 11, prepared by the U.S. Bureau of Public Roads, available from Federal Highway Administration (<http://www.fhwa.dot.gov>), 400 7th Street, S.W., Washington, D.C. 20590, HNG-31, or the procedure in the USDA-NRCS's Engineering Field Manual, Chapter 16 (<http://www.info.usda.gov/CED/>).

**Velocity** - Maximum design velocity shall be as shown below. Except for short transition sections, flow with a channel gradient within the range of 0.7 to 1.3 of this flow's critical slope must be avoided unless the channel is straight. Velocities exceeding critical will be restricted to straight reaches.

Design Flow Depth (ft.)	Maximum Velocity (ft./sec.)
0.0 – 0.5	25
0.5 – 1.0	15
Greater than 1.0	10

Waterways or outlets with velocities exceeding critical shall discharge into an energy dissipater to reduce velocity to less than critical, or to a velocity the downstream soil and vegetative conditions will allow.

**Cross Section** - The cross section shall be triangular, parabolic, or trapezoidal. Monolithic concrete or gabions may be rectangular.

**Freeboard** - The minimum freeboard for lined waterways or outlets shall be 0.25 feet above design high water in areas where erosion resistant vegetation cannot be grown adjacent to the paved side slopes. No freeboard is required where good vegetation can be grown and is maintained.

**Side Slope** - Steepest permissible side slopes, horizontal to vertical will be as follows:

1. Non-Reinforced Concrete
  - Hand-placed, formed concrete
  - Height of lining, 1.5 ft or less..... Vertical
  - Hand placed screened concrete or mortared
  - In-place flagstone
  - Height of lining, less than 2 ft..... 1 to 1
  - Height of lining, more than 2 ft..... 2 to 1
2. Slip form concrete:
  - Height of lining, less than 3 ft..... 1 to 1
3. Rock Riprap..... 2 to 1
4. Gabions..... Vertical
5. Pre-cast Concrete Sections.....Vertical

**Lining Thickness** - Minimum lining thickness shall be as follows:

1. Concrete - 4 in. (In most problem areas, shall be 5 in. with welded wire fabric reinforcing.)
2. Rock Riprap - 1.5 x maximum stone size plus thickness of filter or bedding.
3. Flagstone - 4 in. including mortar bed.

**Related Structures** -Side inlets, drop structures, and energy dissipaters shall meet the hydraulic and structural requirements of the site.

**Filters or Bedding** - Filters or bedding to prevent piping, reduce uplift pressure, and collect water will be used as required and will be designed in accordance with sound engineering principles. Weep holes and drains should be provided as needed.

**Concrete** - Concrete used for lining shall be so proportioned that it is plastic enough for thorough consolidation and stiff enough to stay in place on side slopes. A dense product will be required. A mix that can be certified as suitable to produce a minimum strength of at least 3,000 pounds per square inch will be required. Cement used shall be Portland Cement, Type I, II, IV, or V. Aggregate used shall have a maximum diameter of 1 ½ inches. Weep holes should be provided in concrete footings and retaining walls to allow free drainage of water. Pipe used for weep holes shall be non-corrosive.

**Mortar** - Mortar used for mortared in-place flagstone shall consist of a mix of cement, sand, and water. Follow directions on the bag of mortar for proper mixing of mortar and water.

**Contraction Joints** - Contraction joints in concrete linings, where required, shall be formed transversely to a depth of about one third the thickness of the lining at a uniform spacing in the range of 10 to 15 feet.

**Rock Riprap or Flagstone** - Stone used for riprap or gabions shall be dense and hard enough to withstand exposure to air and water. Flagstone shall be flat for ease of placement and have the strength to resist exposure and breaking. Rock riprap maximum size shall be as follows:

<u>Velocity, f.p.s.</u>	<u>dmax, inches</u>
5.0	6
8.5	12
10	18
12	24
15	36

**Cutoff Walls** - Cutoff walls shall be used at the beginning and ending of concrete lining. For rock riprap lining, cutoff walls shall be keyed into the channel bottom and at both ends of the lining.

### ***Construction Specifications***

1. The foundation area shall be cleared of trees, stumps, roots, loose rock, or other objectionable material.
2. The cross-section shall be excavated to the neat lines and grades as shown on the plans. Over-excavated areas shall be backfilled with moist soil compacted to the density of the surrounding material.
3. No abrupt deviations from design grade or horizontal alignment shall be permitted.
4. Concrete linings shall be placed to the thickness shown on the plans and finished in a workmanlike manner. Adequate precautions shall be taken to protect freshly placed concrete from extreme temperatures, to ensure proper curing.
5. Filter bedding and rock riprap shall be placed to line and grade in the manner specified.
6. Construction operation shall be done in such a manner that erosion, air pollution, and water pollution will be minimized and held within legal limits. The completed job shall present a workmanlike appearance. All disturbed areas shall be vegetated or otherwise protected against soil erosion.

### ***Maintenance***

Pavement or lining should be maintained as built to prevent undermining and deterioration. Existing trees next to pavements should be removed, as roots can cause uplift damage. Vegetation next to pavement should be maintained in good condition to prevent scouring if the pavement is overtopped.

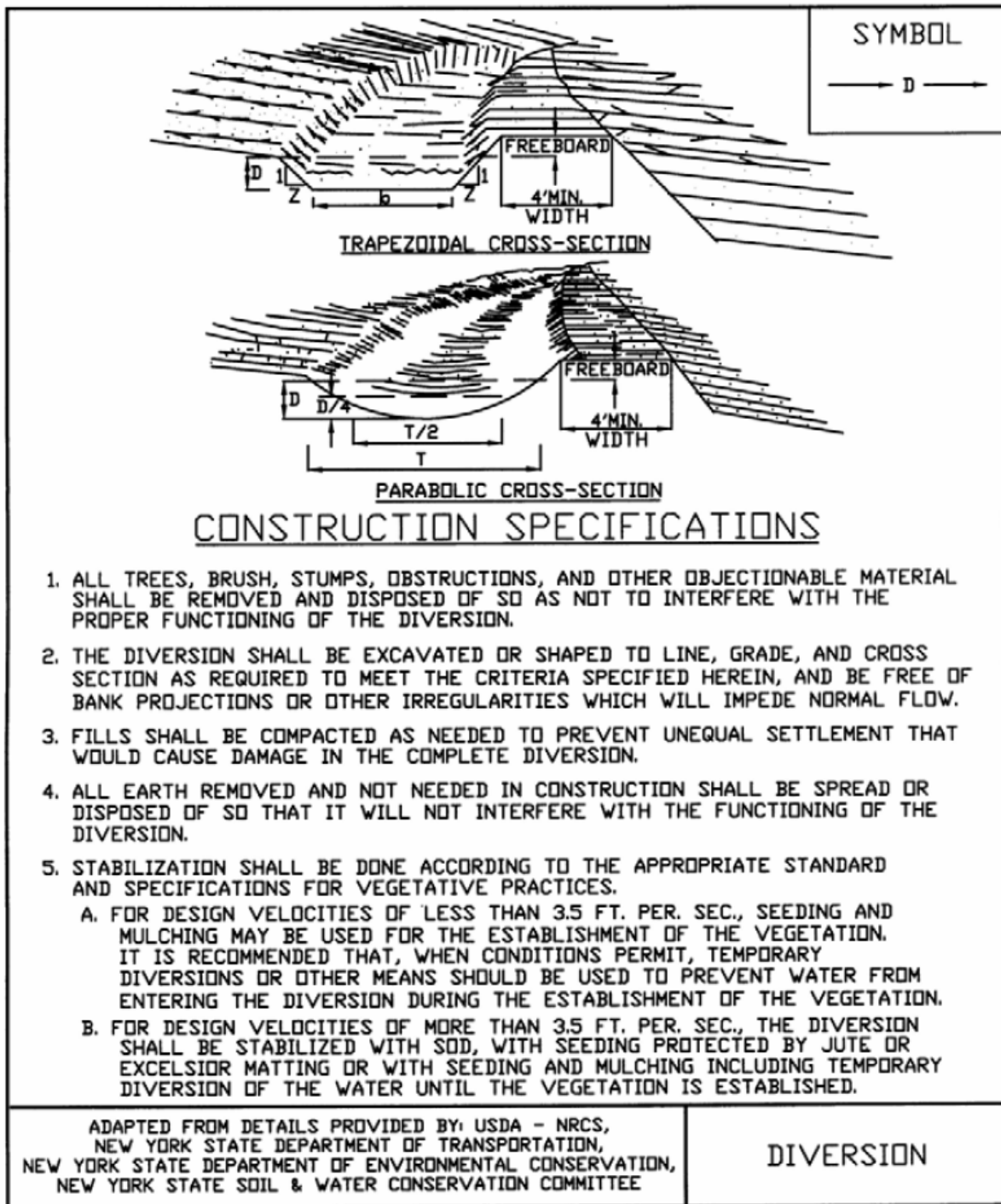

Figure A11.1 Waterway (Diversion)

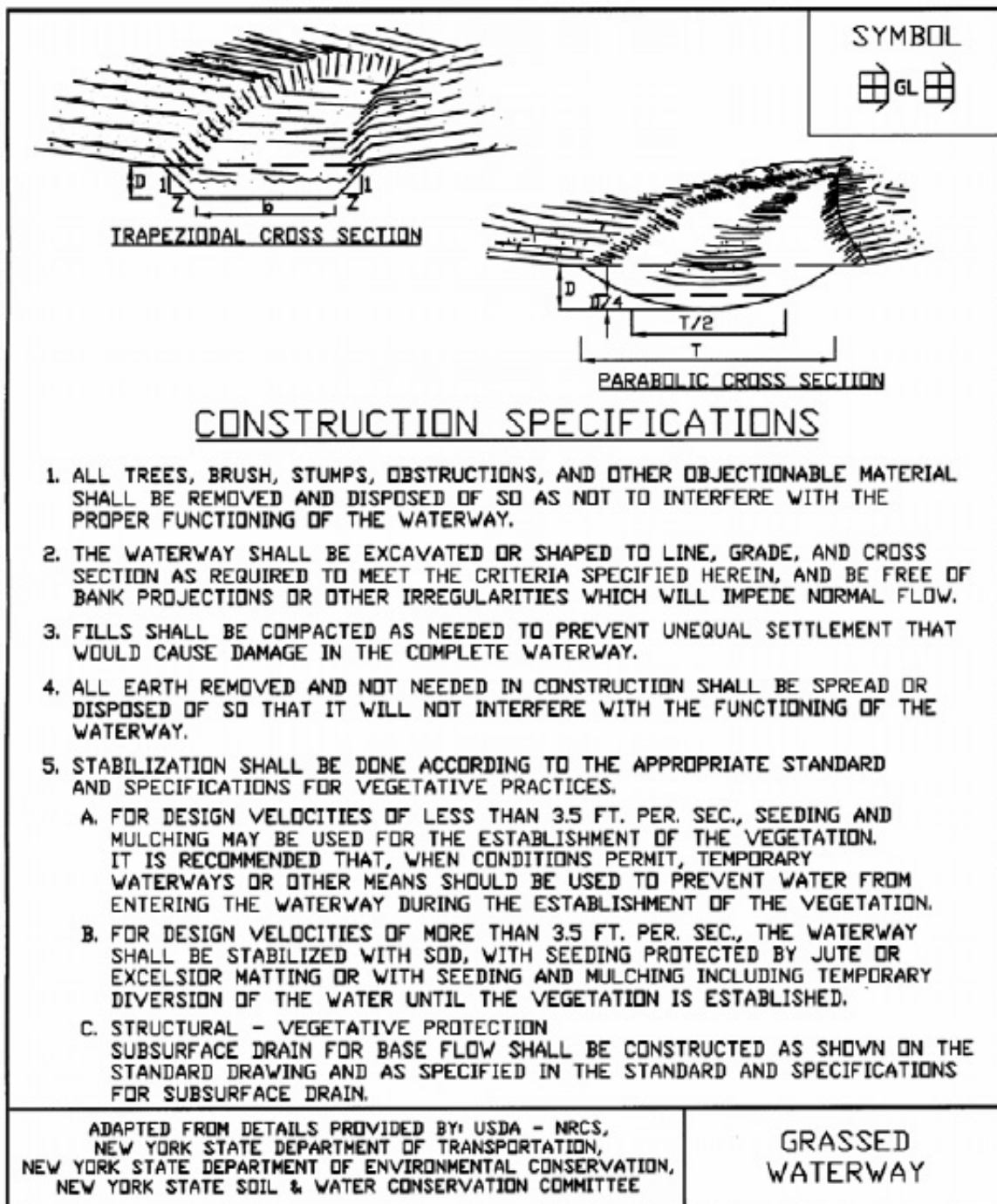

Figure A11.2 Grassed Waterway



## **A12: Rock Outlet Protection**

### **Definition**

A section of rock protection placed at the outlet end of the culverts, conduits, or channels.

### **Purpose**

The purpose of the rock outlet protection is to reduce the depth, velocity, and energy of water, such that the flow will not erode the receiving downstream reach.

### **Scope**

This standard applies to the planning, design, and construction of rock riprap and gabions for protection of downstream areas. It does not apply to rock lining of channels or streams.

### **Conditions Where Practice Applies**

This practice applies where discharge velocities and energies at the outlets of culverts, conduits, or channels are sufficient to erode the next downstream reach. This applies to:

1. Culvert outlets of all types.
2. Pipe conduits from all sediment basins, dry storm water ponds, and permanent type ponds.
3. New channels constructed as outlets for culverts and conduits.

### **Design Guidance**

The design of rock outlet protection depends entirely on the location. Pipe outlet at the top of cuts or on slopes steeper than 10 percent, cannot be protected by rock aprons or riprap sections due to re-concentration of flows and high velocities encountered after the flow leaves the apron.

**Tailwater Dept h-** The depth of tailwater immediately below the pipe outlet must be determined for the design capacity of the pipe. If the tailwater depth is less than half the diameter of the outlet pipe, and the receiving stream is wide enough to accept divergence of the flow, it shall be classified as a Minimum Tailwater Condition. If the tailwater depth is greater than half the pipe diameter and the receiving stream will continue to confine the flow, it shall be classified as a Maximum Tailwater Condition. Pipes which outlet onto flat areas with no defined channel may be assumed to have a Minimum Tailwater Condition.

**Apron Size** -The apron length and width shall be determined from the curves according to the tailwater conditions:

Minimum Tailwater – Use **Figure 12.1**

Maximum Tailwater – Use **Figure 12.2**

If the pipe discharges directly into a well defined channel, the apron shall extend across the channel bottom and up the channel banks to an elevation one foot above the maximum tailwater depth or to the top of the bank, whichever is less. The upstream end of the apron, adjacent to the pipe, shall have a width two (2) times the diameter of the outlet pipe, or conform to pipe end section if used.

**Bottom Grade** - The outlet protection apron shall be constructed with no slope along its length. There shall be no overfall at the end of the apron. The elevation of the downstream end of the apron shall be equal to the elevation of the receiving channel or adjacent ground.

**Alignment** - The outlet protection apron shall be located so that there are no bends in the horizontal alignment.

**Materials** - The outlet protection may be done using rock riprap, grouted riprap, or gabions. Riprap shall be composed of a well-graded mixture of stone size so that 50 percent of the pieces, by weight, shall be larger than the d<sub>50</sub> size determined by using the charts. A well-graded mixture, as used herein, is defined as a mixture composed primarily of larger stone sizes, but with a sufficient mixture of other sizes to fill the smaller voids between the stones. The diameter of the largest stone size in such a mixture shall be 1.5 times the d<sub>50</sub> size.

**Thickness** - The minimum thickness of the riprap layer shall be 1.5 times the maximum stone diameter for d<sub>50</sub> of 15 inches or less; and 1.2 times the maximum stone size for d<sub>50</sub> greater than 15 inches. The following chart lists some examples:

D <sub>50</sub> (inches)	d <sub>max</sub> (inches)	Minimum Blanket Thickness (inches)
4	6	9
6	9	14
9	14	20
12	18	27
15	22	32
18	27	32
21	32	38
24	36	43

**Stone Quality** - Stone for riprap shall be hard and angular and of a quality that will not disintegrate on exposure to water or weathering. The specific gravity of the individual stones shall be at least 2.5. Recycled concrete equivalent may be used provided it has a density of at least 150 pounds per cubic foot, and does not have any exposed steel or reinforcing bars.

**Filter** - A filter is a layer of material placed between the riprap and the underlying soil surface to prevent soil movement into and through the riprap. Riprap shall have a filter placed under it in all cases. A filter can be of two general forms: a gravel layer or a plastic filter cloth. The plastic filter cloth can be woven or non-woven monofilament yarns, and shall meet these base requirements: thickness 20-60 mils, grab strength 90-120 lbs; and shall conform to ASTM D-1777 and ASTM D-1682. Gravel filter blanket, when used, shall be designed by comparing particle sizes of the overlying material and the base material.

**Gabions** - Gabions shall be made of hexagonal triple twist mesh with heavily galvanized steel wire. The maximum linear dimension of the mesh opening shall not exceed 4 ½ inches and the area of the mesh opening shall not exceed 10 square inches. Gabions shall be fabricated in such a manner that the sides, ends, and lid can be assembled at the construction site into a rectangular

basket of the specified sizes. Gabions shall be of single unit construction and shall be installed according to manufacturer's recommendations. The area on which the gabion is to be installed shall be graded as shown on the drawings. Foundation conditions shall be the same as for placing rock riprap, and filter cloth shall be placed under all gabions. Where necessary, key, or tie, the structure into the bank to prevent undermining of the main gabion structure.

### **Maintenance**

Once a riprap outlet has been installed, the maintenance needs are very low. It should be inspected after high flows for evidence of scour beneath the riprap or for dislodged stones. Repairs should be made immediately.

### **Construction Specifications**

1. The subgrade for the filter, riprap, or gabion shall be prepared to the required lines and grades. Any fill required in the subgrade shall be compacted to a density of approximately that of the surrounding undisturbed material.
2. The rock or gravel shall conform to the specified grading limits when installed respectively in the riprap or filter.
3. Filter cloth shall be protected from punching, cutting, or tearing. Any damage other than an occasional small hole shall be repaired by placing another piece of cloth over the damaged part or by completely replacing the cloth. All overlaps, whether for repairs or for joining two pieces of cloth shall be a minimum of one foot.
4. Stone for the riprap or gabion outlets may be placed by equipment. Both shall each be constructed to the full course thickness in one operation and in such a manner as to avoid displacement of underlying materials. The stone for riprap or gabion outlets shall be delivered and placed in a manner that will ensure that it is reasonably homogenous with the smaller stones and spalls filling the voids between the larger stones. Riprap shall be placed in a manner to prevent damage to the filter blanket or filter cloth. Hand placement will be required to the extent necessary to prevent damage to the permanent works.

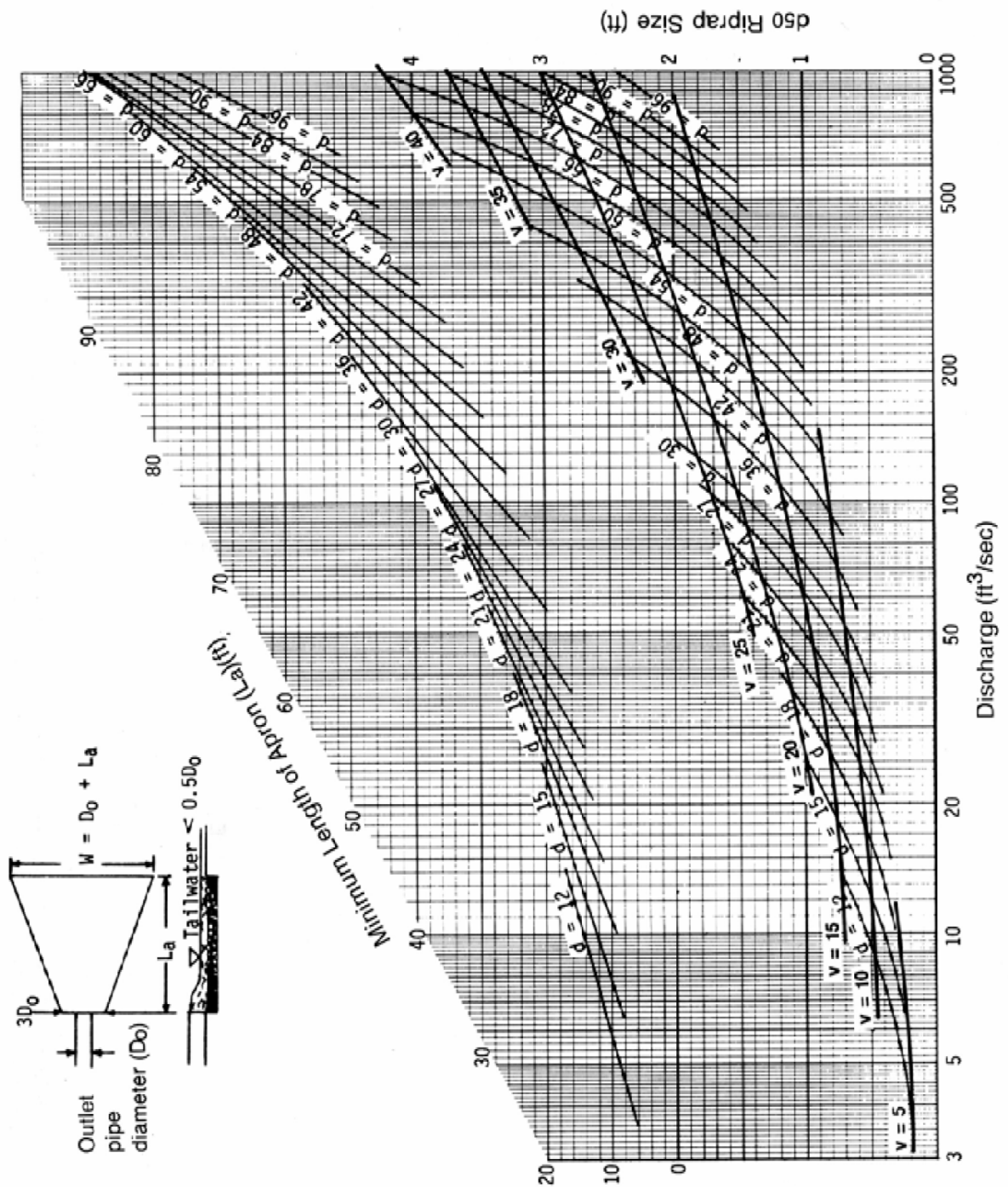

**Figure A12.1 Outlet Protection Design – Minimum Tailwater Condition (Design of Outlet Protection from a Round Pipe Flowing Full, Minimum Tailwater Condition:  $T_w < 0.5 D_0$ ) (USDA-NRCS)**

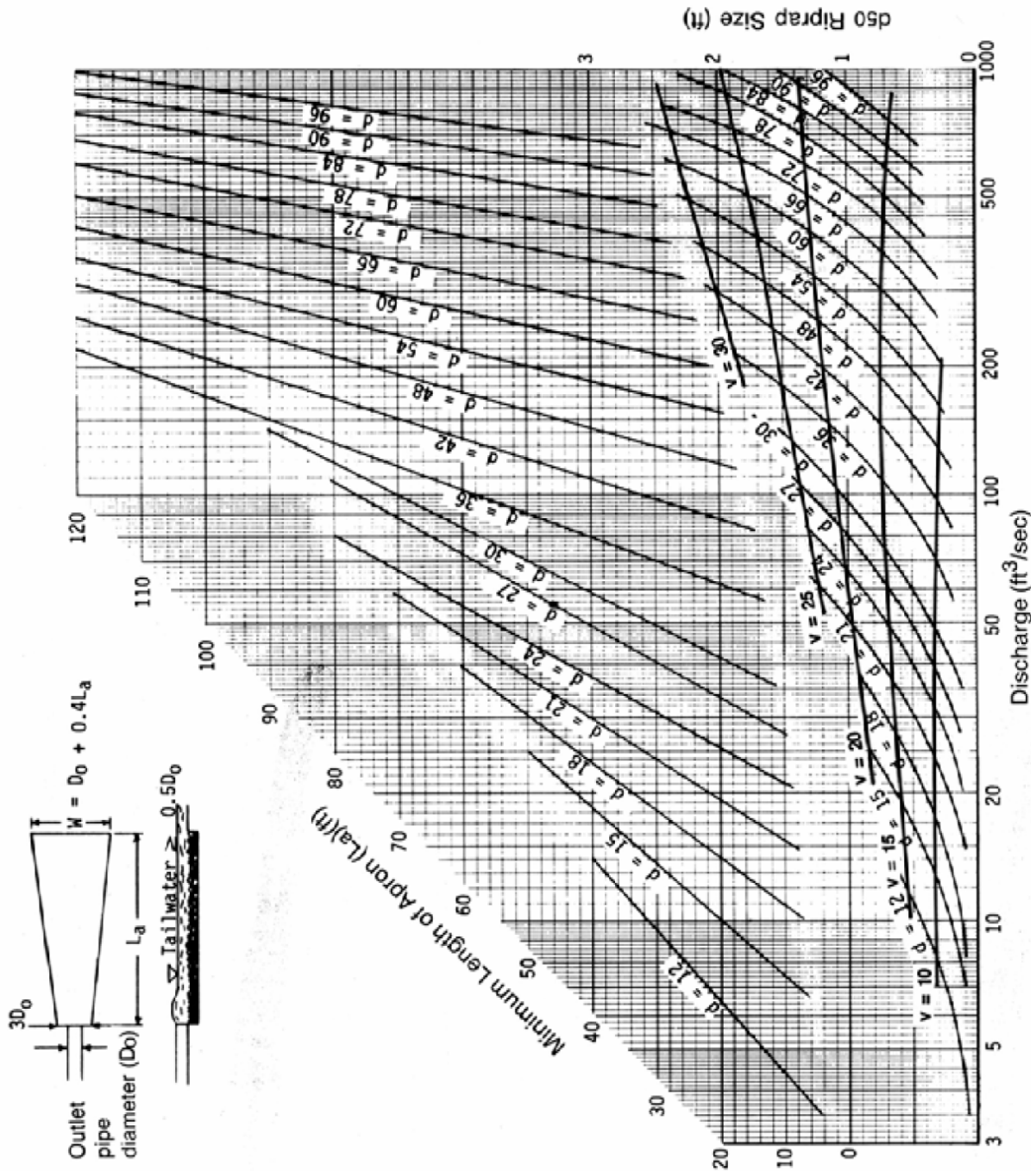

**Figure A12.2 Outlet Protection Design – Maximum Tailwater Condition (Design of Outlet Protection from a Round Pipe Flowing Full, Maximum Tailwater Condition:  $T_w \geq 0.5 D_o$ ) (USDA-NRCS)**

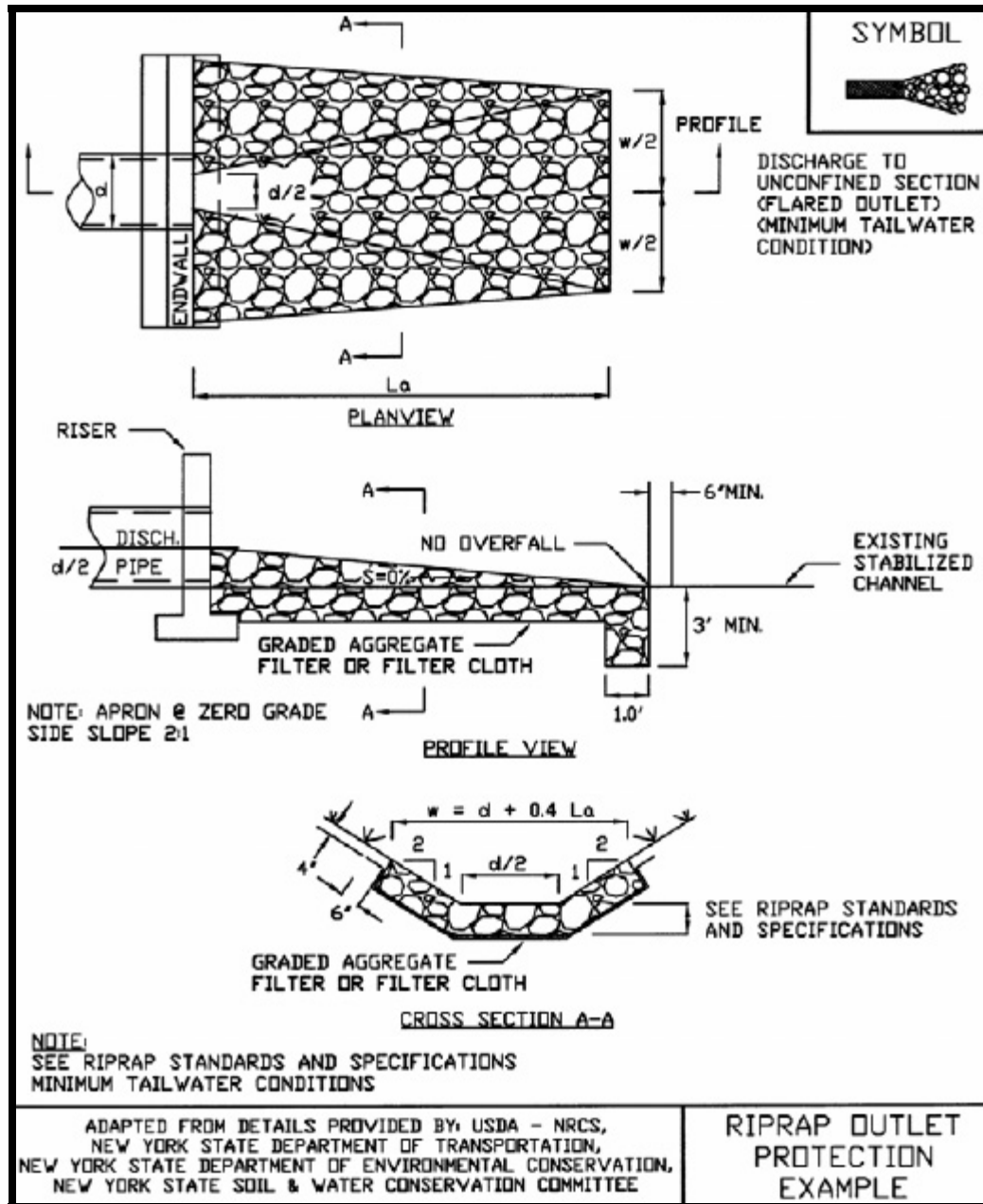

Figure A12.3 Rock Outlet Protection: Discharge to Unconfined Section

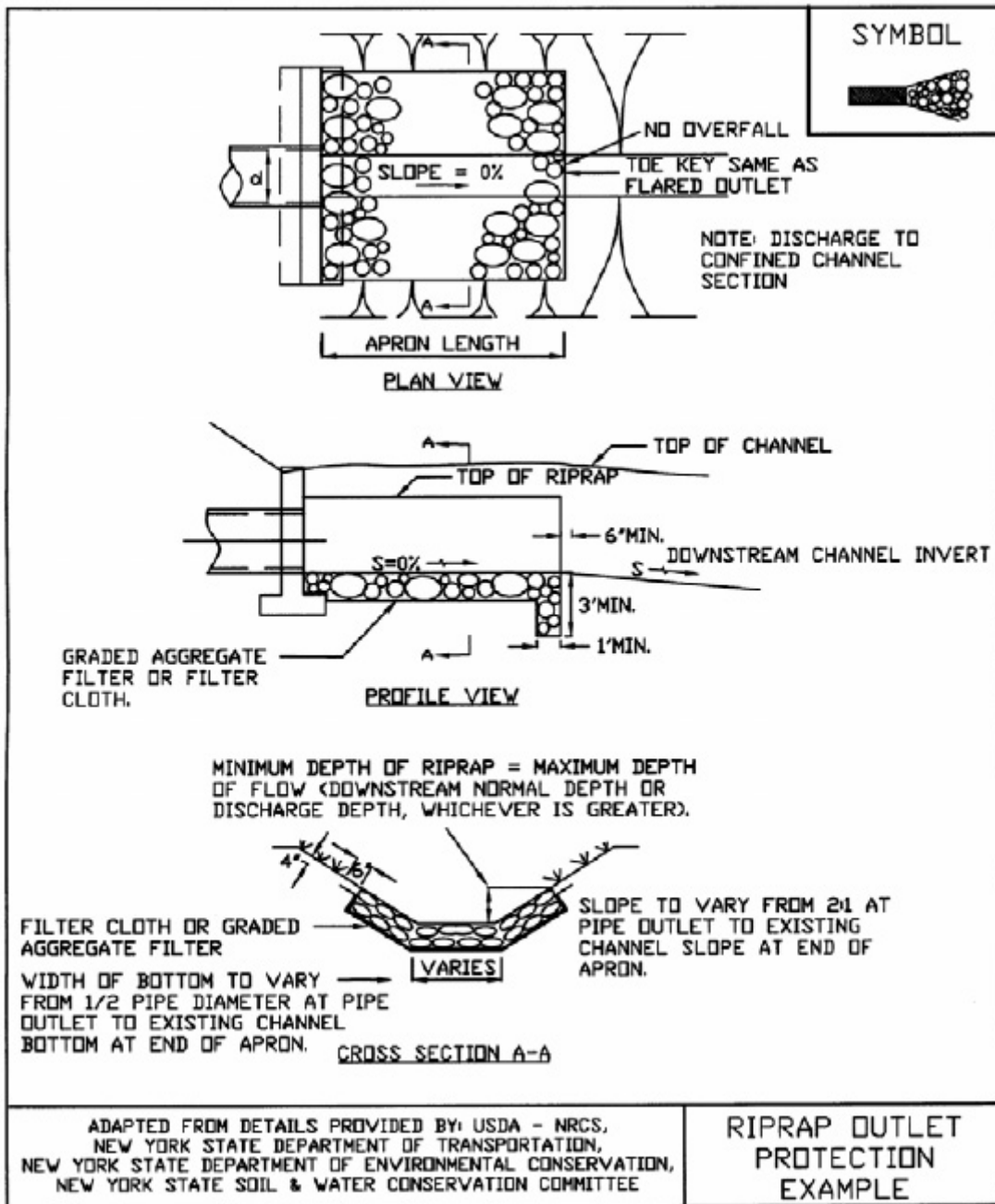

Figure A12.4 Riprap Outlet Protection: Discharge to Confined Section

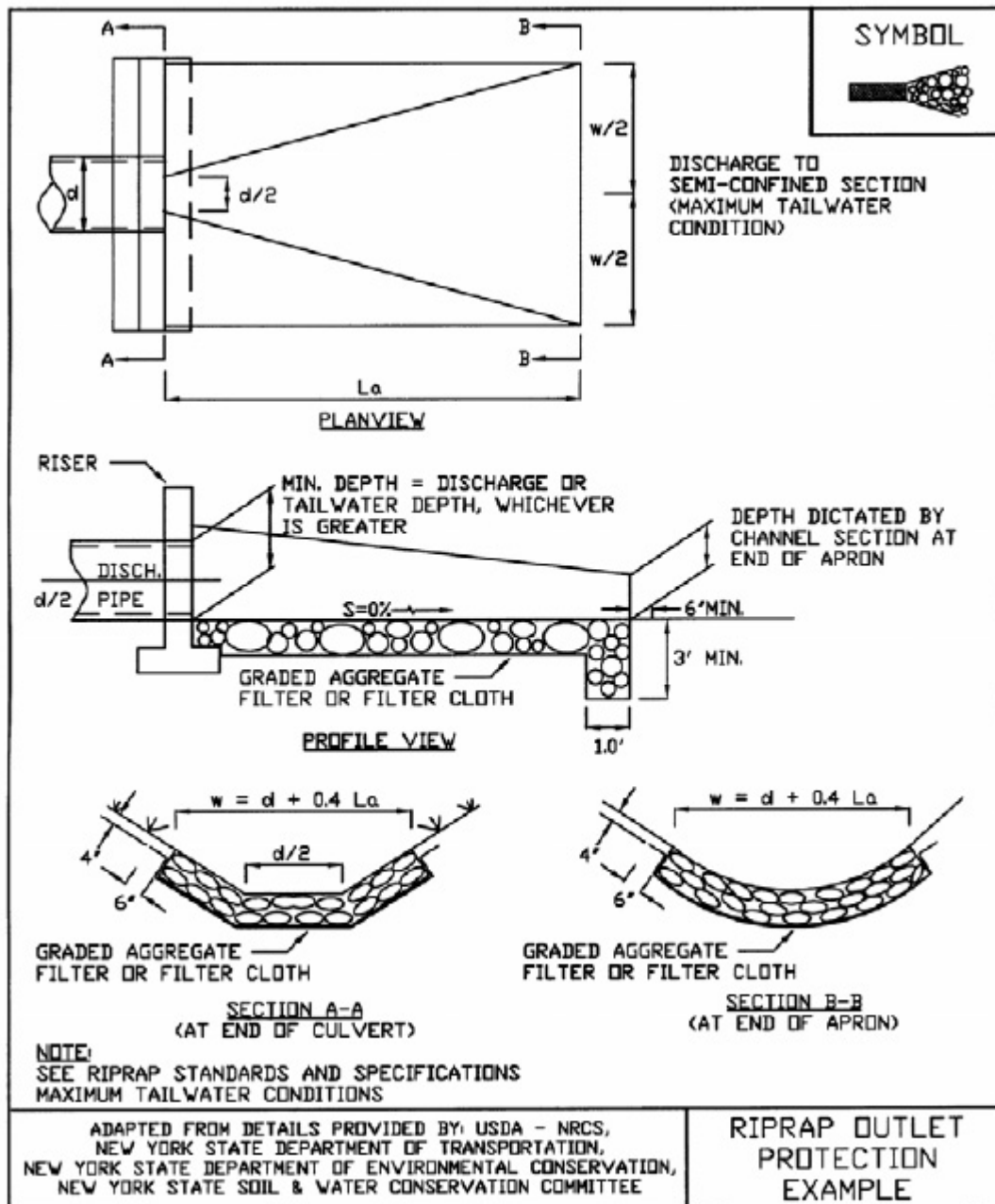

Figure A12.5 Riprap Outlet Protection: Discharge to Semi-confined Section



## **A13: Erosion Control Blankets**

### **Description**

Erosion control blankets, also known as geotextiles, are porous fabrics also known as filter fabrics, road rugs, synthetic fabrics, construction fabrics, or simply fabrics. Geotextiles are manufactured by weaving or bonding fibers made from synthetic materials such as polypropylene, polyester, polyethylene, nylon, polyvinyl chloride, glass, and various mixtures of these materials. As a synthetic construction material, geotextiles are used for a variety of purposes such as separators, reinforcement, filtration and drainage, and erosion control.

Some geotextiles are made of biodegradable materials such as mulch matting and netting. Mulch mattings are jute or other wood fibers that have been formed into sheets and are more stable than normal mulch. Netting is typically made from jute, wood fiber, plastic, paper, or cotton and can be used to hold the mulching and matting to the ground. Netting can also be used alone to stabilize soils while the plants are growing; however, it does not retain moisture or temperature well. Mulch binders (either asphalt or synthetic) are sometimes used instead of netting to hold loose mulches together. Geotextiles can aid in plant growth by holding seeds, fertilizers, and topsoil in place. Fabrics are relatively inexpensive for certain applications. A wide variety of geotextiles exist to match the specific needs of the site.

### **Applicability**

Geotextiles can be used alone for erosion control. Geotextiles can be used as matting, which is used to stabilize the flow of channels or swales or to protect seedlings on recently planted slopes until they become established. Matting may be used on tidal or stream banks, where moving water is likely to wash out new plantings. They can also be used to protect exposed soils immediately and temporarily, such as when active piles of soil are left overnight. Geotextiles are also used as separators; for example, as a separator between riprap and soil. This "sandwiching" prevents the soil from being eroded from beneath the riprap and maintains the riprap's base.

### **Siting and Design Considerations**

There are many types of geotextiles available. Therefore, the selected fabric should match its purpose. All local requirements, design procedures, and any other applicable requirements should be considered. Effective netting and matting require firm, continuous contact between the materials and the soil. If there is no contact, the material will not hold the soil, and erosion will occur underneath the material.

### **Limitations**

Geotextiles (primarily synthetic types) have the potential disadvantage of being sensitive to light and must be protected prior to installation. Some geotextiles might promote increased runoff and might blow away if not firmly anchored. Depending on the type of material used, geotextiles might need to be disposed of in a landfill, making them less desirable than vegetative stabilization. If the fabric is not properly selected, designed, or installed, the effectiveness may be reduced drastically.

### **Maintenance Considerations**

Regular inspections should be made to determine if cracks, tears, or breaches have formed in the fabric; if so, it should be repaired or replaced immediately. It is necessary to maintain contact

between the ground and the geotextile at all times. Trapped sediment should be removed after each storm event.

**Effectiveness**

Geotextiles' effectiveness depends upon the strength of the fabric and proper installation. For example, when protecting a cut slope with a geotextile, it is important to properly anchor the fabric. This will ensure that it will not be undermined by a storm event.

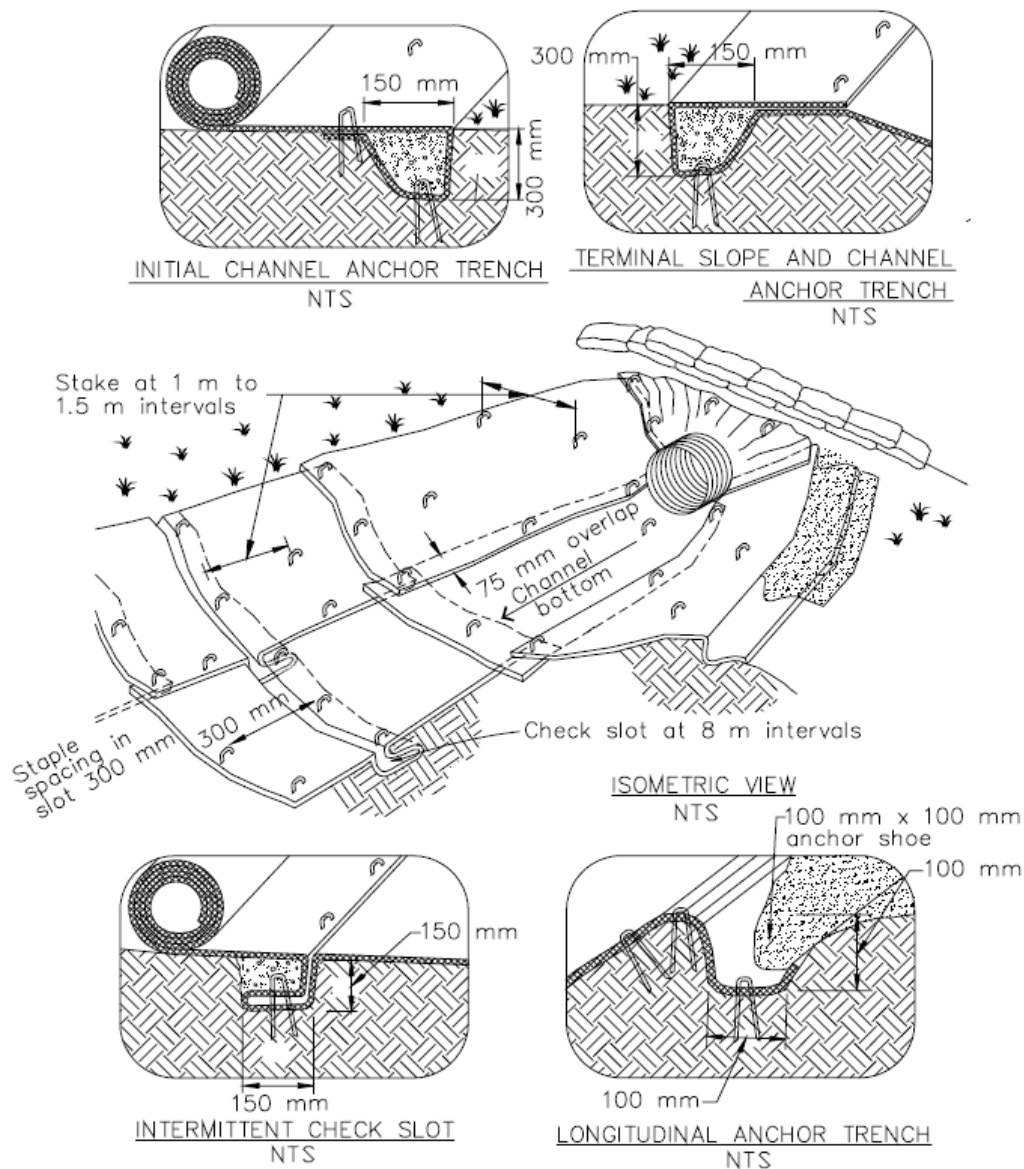

- NOTES:
1. Check slots to be constructed per manufacturers specifications.
  2. Staking or stapling layout per manufacturers specifications.
  3. Install per manufacturer's recommendations

**Figure A13.1 Erosion Control Blanket – Channel Stabilization**  
 (from State of California DOT Construction Site BMPs Manual, 2003)

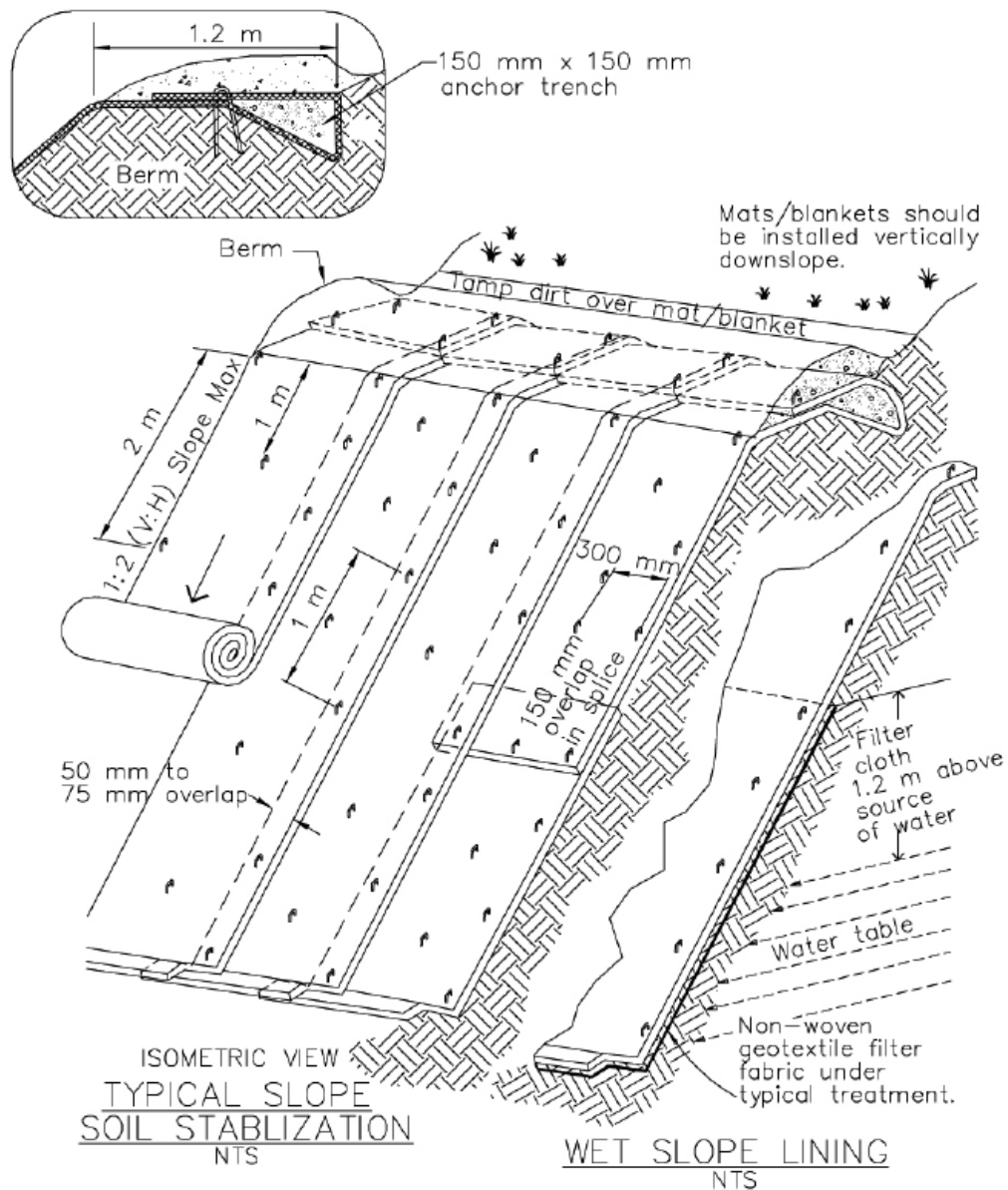

NOTES:

1. Slope surface shall be free of rocks, clods, sticks and grass. Mats/blankets shall have good soil contact.
2. Lay blankets loosely and stake or staple to maintain direct contact with the soil. Do not stretch.
3. Install per manufacturer's recommendations

**Figure A13.2 Erosion Control Blanket – Slope Stabilization**  
 (from State of California DOT Construction Site BMPs Manual, 2003)

## **A14: Stabilization with Vegetation, Mulch, or Topsoil**

### **Definitions**

***Stabilization with Vegetation*** - Providing erosion control protection to a critical area for an interim period or establishing grasses with other forbs and/or shrubs to provide perennial vegetative cover on disturbed, denuded, slopes subject to erosion.

***Stabilization with Topsoil*** - Spreading a specified quality and quantity of topsoil materials on graded or constructed subsoil areas.

***Stabilization with Mulch*** - Applying coarse plant residue or chips, or other suitable materials, to cover the soil surface.

### **Purpose**

***Stabilization with Vegetation*** - To provide temporary and/or permanent erosion and sediment control. Temporary control is achieved by covering all bare ground areas that exist as a result of construction or a natural event.

***Stabilization with Topsoil*** - To provide acceptable plant cover growing conditions, thereby reducing erosion; to reduce irrigation water needs; and to reduce the need for nitrogen fertilizer application.

***Stabilization with Mulch*** - The primary purpose is to provide initial erosion control while a seeding or shrub planting is establishing. Mulch will conserve moisture and modify the surface soil temperature and reduce fluctuation of both. Mulch will prevent soil surface crusting and aid in weed control. Mulch is also used alone for temporary stabilization in nongrowing months.

### **Conditions Where Practice Applies**

***Stabilization with Vegetation*** - Temporary seedings may be necessary on construction sites to protect an area, or section, where final grading is complete or to provide cover when permanent seedings are likely to fail due heavy rain during the wet season or to drought during the dry season. The intent is to provide temporary protective cover during temporary shutdown of construction and/or while waiting for optimal planting time. Permanent vegetation applies to all disturbed areas void of, or having insufficient, cover to prevent erosion and sediment transport.

***Stabilization with Topsoil*** - Topsoil is applied to subsoils that are droughty (low available moisture for plants), stony, slowly permeable, salty or extremely acid. It is also used to backfill around shrub and tree transplants. This standard does not apply to wetland soils.

***Stabilization with Mulch*** - On soils subject to erosion and on new seedings and shrub plantings. Mulch is useful on soils with low infiltration rates by retarding runoff.

### **Guidance for Topsoiling**

1. Preserve existing topsoil in place where possible, thereby reducing the need for added topsoil.
2. Conserve by stockpiling topsoil and friable fine textured subsoils that must be stripped from the excavated site and applied after final grading where vegetation will be established.

3. Refer to USDA Soil Conservation Service (presently Natural Resource Conservation Service) soil surveys or soil interpretation record sheets for further soil texture information for selecting appropriate design topsoil depths.

### ***Site Preparation***

1. As needed, install erosion control practices such as diversions, channels, sediment traps, and stabilizing measures, or maintain if already installed.
2. Complete rough grading and final grade, allowing for depth of topsoil to be added.
3. Scarify all compact, slowly permeable, medium and fine textured subsoil areas. Scarify at approximately right angles to the slope direction in soil areas that are steeper than 5 percent. Areas that have been overly compacted shall be decompacted to a minimum depth of 12 inches with a deep ripper or chisel plow prior to topsoiling.
4. Remove refuse, woody plant parts, stones over 3 inches in diameter, and other litter.

### ***Topsoil Materials***

Topsoil soil shall be of material appropriate for local conditions.

### ***Application and Grading***

1. Topsoil shall be distributed to a uniform depth over the area. It shall not be placed when it is muddy or over standing water puddles.
2. Topsoil placed and graded on slopes steeper than 5 percent shall be promptly fertilized, seeded, mulched, and stabilized by “tracking” with suitable equipment.

### ***Guidance for Mulching***

Site preparation prior to mulching requires the installation of necessary erosion control or water management practices and drainage systems. Slope, grade and smooth the site to fit needs of selected mulch products. Remove all undesirable stones and other debris to meet the needs of the anticipated land use and maintenance required. Apply mulch after soil amendments and planting is accomplished or simultaneously if hydroseeding is used. Select appropriate mulch material and application rate or material needs. Determine local availability. Select appropriate mulch anchoring material.