

USED OIL MANAGEMENT

FOR AUTO REPAIR SHOPS

In November 2006, members of the Auto Repair Shop industry sector on Saipan met with CNMI DEQ in a roundtable discussion to identify high-priority areas for preventing pollution and improving environmental compliance. Surface water and groundwater protection emerged as an important responsibility for shop owners and a topic DEQ will focus on during 2007.



USED OIL – A THREAT TO SAIPAN RESOURCES

Used oil from auto repair shops is a potential threat to Saipan's natural beauty. Saipan has a close relationship with water and, simply put, oil and water don't mix.

Saipan's drinking water comes mostly from ground water that can be ruined by spills on bare soil. Similarly, Saipan's economy relies heavily on tourism and damage to coastal water (directly through spills or indirectly

through storm water runoff) can damage coastal reefs that the tourists visit. For these reasons, shop owners must manage their used oil carefully.

TWO BASIC RULES YOU MUST KNOW

There are two main rules for preventing pollution from used oil:

Rule #1: Keep the oil from contacting the soil

Rule #2: Keep the used oil containers covered (that is, out of the rain).

To comply with the two rules, follow these best management practices (BMP):

- Conduct all work on an concrete or paved asphalt
- Clean up spills immediately - no free standing liquids *anywhere*
- Protect drains from spills – use “pigs” or mats to divert or contain spills
- Store used oil in drums with no rust, dents, or bulges
- Store **no more than five (5)** 55-gallon drums of used oil at any time



USED OIL STORAGE REQUIREMENTS

In addition to the BMPs described above, shops storing used oil **must follow requirements** established by CNMI DEQ:

- ✓ Store used oil drums on a concrete pad with no cracks.

USED OIL MANAGEMENT

FOR AUTO REPAIR SHOPS (CONT.)

- ✓ The concrete pad must have a concrete (or similar impervious material) berm (short wall) with no cracks.
- ✓ The pad and berm must provide a containment volume at least 110% of the maximum amount of used oil stored. If the maximum of five (5) drums are stored, the required containment volume is 302.5 gallons.
- ✓ The storage area must be covered.
- ✓ The storage area must have a sump to remove spills or rain water.
- ✓ The storage area must be labeled: "Used Oil Storage"
- ✓ Each drum in the storage area must be labeled "Used Oil"
- ✓ Each drum label should indicate the date the drum was placed into the storage area.

Example dimensions of a used oil storage area capable of storing five (5) 55-gallon drums in compliance with DEQ requirements are shown below.

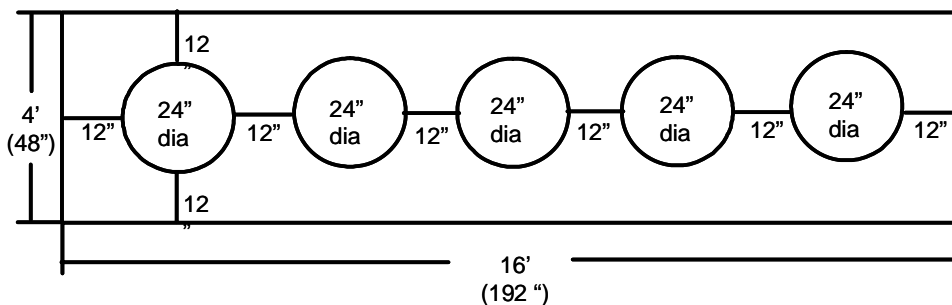

Berm walls should be 8 inches high.
Containment volume = 42.6 cubic feet or 318.6 gallons.

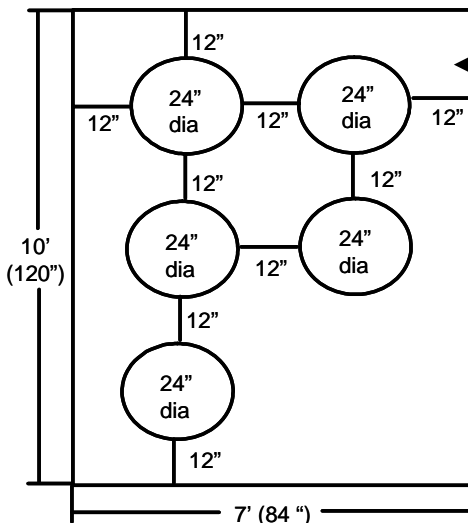

Berm walls should be 9 inches high.
Containment volume = 52.5 cubic feet or 392.7 gallons.

Do your part to protect Saipan's natural resources and the reputation of the auto repair industry: Prevent oil spills and store used oil properly. For more information contact:

**Division of Environmental Quality
Storage, Tank, Oil, Pesticide (STOP) Division
Gualo Rai Center
P.O. Box 501304, Saipan, MP 96950**



Call CNMI DEQ at 670-664-8500 for more ideas about environmental protection and information about complying with local regulations.